



CYPRESS

PRELIMINARY

CY7C0837V

CY7C0830V/CY7C0831V

CY7C0832V/CY7C0833V

FLEx18™ 3.3V 32K/64K/128K/256K/512K x 18 Synchronous Dual-Port RAM

Features

- True dual-ported memory cells that allow simultaneous access of the same memory location
- Synchronous pipelined operation
- Family of 512-Kbit, 1-Mbit, 2-Mbit, 4-Mbit and 9-Mbit devices
- Pipelined output mode allows fast operation
- 0.18-micron CMOS for optimum speed and power
- High-speed clock to data access
- 3.3V low power
 - Active as low as 225 mA (typ)
 - Standby as low as 55 mA (typ)
- Mailbox function for message passing
- Global master reset
- Separate byte enables on both ports
- Commercial and industrial temperature ranges
- IEEE 1149.1-compatible JTAG boundary scan
- 144-ball FBGA (13 mm x 13 mm) (1.0 mm pitch)
- 120TQFP (14 mm x 14 mm x 1.4 mm)
- Counter wrap around control
 - Internal mask register controls counter wrap-around
 - Counter-interrupt flags to indicate wrap-around
 - Memory block retransmit operation
- Counter readback on address lines
- Mask register readback on address lines
- Dual Chip Enables on both ports for easy depth expansion

Functional Description

The FLEx18 family includes 512-Kbit, 1-Mbit, 2-Mbit, 4-Mbit and 9-Mbit pipelined, synchronous, true dual-port static RAMs that are high-speed, low-power 3.3V CMOS. Two ports are provided, permitting independent, simultaneous access to any location in memory. The result of writing to the same location by more than one port at the same time is undefined. Registers on control, address, and data lines allow for minimal set-up and hold time.

During a Read operation, data is registered for decreased cycle time. Each port contains a burst counter on the input address register. After externally loading the counter with the initial address, the counter will increment the address internally (more details to follow). The internal Write pulse width is independent of the duration of the R/W input signal. The internal Write pulse is self-timed to allow the shortest possible cycle times.

A HIGH on $\overline{CE0}$ or LOW on CE1 for one clock cycle will power down the internal circuitry to reduce the static power consumption. One cycle with chip enables asserted is required to reactivate the outputs.

Additional features include: readback of burst-counter internal address value on address lines, counter-mask registers to control the counter wrap-around, counter interrupt (CNTINT) flags, readback of mask register value on address lines, retransmit functionality, interrupt flags for message passing, JTAG for boundary scan, and asynchronous Master Reset (MRST).

The CY7C0833V device in this family has limited features. Please see Address Counter and Mask Register Operations^[15] on page 6 for details.

Table 1. Product Selection Guide

Density	512-Kbit (32K x 18)	1-Mbit (64K x 18)	2-Mbit (128K x 18)	4-Mbit (256K x 18)	9-Mbit (512K x 18)
Part Number	CY7C0837V	CY7C0830V	CY7C0831V	CY7C0832V	CY7C0833V
Max. Speed (MHz)	167	167	167	167	133
Max. Access Time - clock to Data (ns)	4.0	4.0	4.0	4.0	4.7
Typical operating current (mA)	225	225	225	225	270
Package	144 FBGA	120 TQFP 144 FBGA	120 TQFP 144 FBGA	120 TQFP 144 FBGA	144 FBGA

Logic Block Diagram^[1]

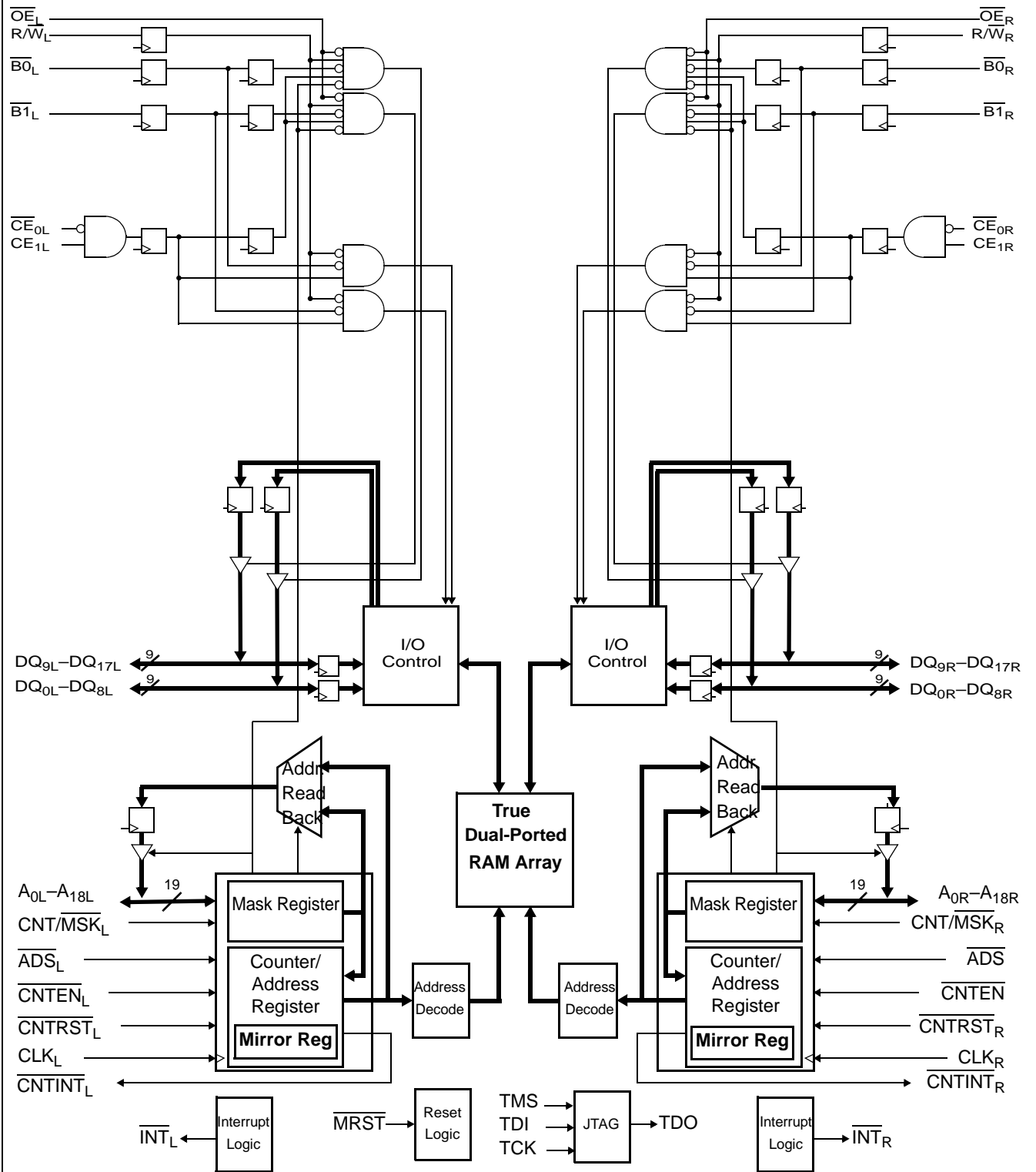

Note:

1. CY7C0837V has 15 address bits, CY7C0830V has 16 address bits, CY7C0831V has 17 address bits, CY7C0832V has 18 address bits and CY7C0833V has 19 address bits



PRELIMINARY

**CY7C0837V
CY7C0830V/CY7C0831V
CY7C0832V/CY7C0833V**

Pin Configurations

**144-ball BGA
Top View**

**CY7C0837V / CY7C0830V / CY7C0831V
CY7C0832V / CY7C0833V**

	1	2	3	4	5	6	7	8	9	10	11	12
A	DQ17 _L	DQ16 _L	DQ14 _L	DQ12 _L	DQ10 _L	DQ9 _L	DQ9 _R	DQ10 _R	DQ12 _R	DQ14 _R	DQ16 _R	DQ17 _R
B	A0 _L	A1 _L	DQ15 _L	DQ13 _L	DQ11 _L	$\overline{\text{MRST}}$	NC	DQ11 _R	DQ13 _R	DQ15 _R	A1 _R	A0 _R
C	A2 _L	A3 _L	CE1 _L [6]	$\overline{\text{INT}}_{\text{L}}$	$\overline{\text{CNTINT}}_{\text{L}}$ [8]	$\overline{\text{ADS}}_{\text{L}}$ [7]	$\overline{\text{ADS}}_{\text{R}}$ [7]	$\overline{\text{CNTINT}}_{\text{R}}$ [8]	$\overline{\text{INT}}_{\text{R}}$	CE1 _R [6]	A3 _R	A2 _R
D	A4 _L	A5 _L	$\overline{\text{CE}}_{\text{0L}}$ [7]	NC	VDDIO _L	VDDIO _L	VDDIO _R	VDDIO _R	NC	$\overline{\text{CE}}_{\text{0R}}$ [7]	A5 _R	A4 _R
E	A6 _L	A7 _L	$\overline{\text{B}}_{\text{1L}}$	NC	VDDIO _L	VSS	VSS	VDDIO _R	NC	$\overline{\text{B}}_{\text{1R}}$	A7 _R	A6 _R
F	A8 _L	A9 _L	C _L	NC	VSS	VSS	VSS	VSS	NC	C _R	A9 _R	A8 _R
G	A10 _L	A11 _L	$\overline{\text{B}}_{\text{0L}}$	NC	VSS	VSS	VSS	VSS	NC	$\overline{\text{B}}_{\text{0R}}$	A11 _R	A10 _R
H	A12 _L	A13 _L	$\overline{\text{OE}}_{\text{L}}$	NC	VDDIO _L	VSS	VSS	VDDIO _R	NC	$\overline{\text{OE}}_{\text{R}}$	A13 _R	A12 _R
J	A14 _L	A15 _L [2]	$\overline{\text{RW}}_{\text{L}}$	NC	VDDIO _L	VDDIO _L	VDDIO _R	VDDIO _R	NC	$\overline{\text{RW}}_{\text{R}}$	A15 _R [2]	A14 _R
K	A16 _L [3]	A17 _L [4]	$\overline{\text{CNTMSK}}_{\text{L}}$ [6]	TDO	$\overline{\text{CNTRST}}_{\text{L}}$ [6]	TCK	TMS	$\overline{\text{CNTRST}}_{\text{R}}$ [6]	TDI	$\overline{\text{CNTMSK}}_{\text{R}}$ [6]	A17 _R [4]	A16 _R [3]
L	A18 _L [5]	NC	DQ6 _L	DQ4 _L	DQ2 _L	$\overline{\text{CNTEN}}_{\text{L}}$ [7]	$\overline{\text{CNTEN}}_{\text{R}}$ [7]	DQ2 _R	DQ4 _R	DQ6 _R	NC	A18 _R [5]
M	DQ8 _L	DQ7 _L	DQ5 _L	DQ3 _L	DQ1 _L	DQ0 _L	DQ0 _R	DQ1 _R	DQ3 _R	DQ5 _R	DQ7 _R	DQ8 _R

Notes:

2. Leave this ball unconnected for CY7C0837V
3. Leave this ball unconnected for CY7C0837V and CY7C0830V
4. Leave this ball unconnected for CY7C0837V, CY7C0830V and CY7C0831V
5. Leave this ball unconnected for CY7C0837V, CY7C0830V, CY7C0831V and CY7C0832V
6. These balls are not applicable for CY7C0833V device. They need to be tied to VDDIO.
7. These balls are not applicable for CY7C0833V device. They need to be tied to VSS.
8. These balls are not applicable for CY7C0833V device. They need to be no connected.



PRELIMINARY

**CY7C0837V
CY7C0830V/CY7C0831V
CY7C0832V/CY7C0833V**

Pin Configurations (continued)

**120-pin Thin Quad Flat Pack (TQFP)
Top View**

CY7C0830V / CY7C0831V / CY7C0832V

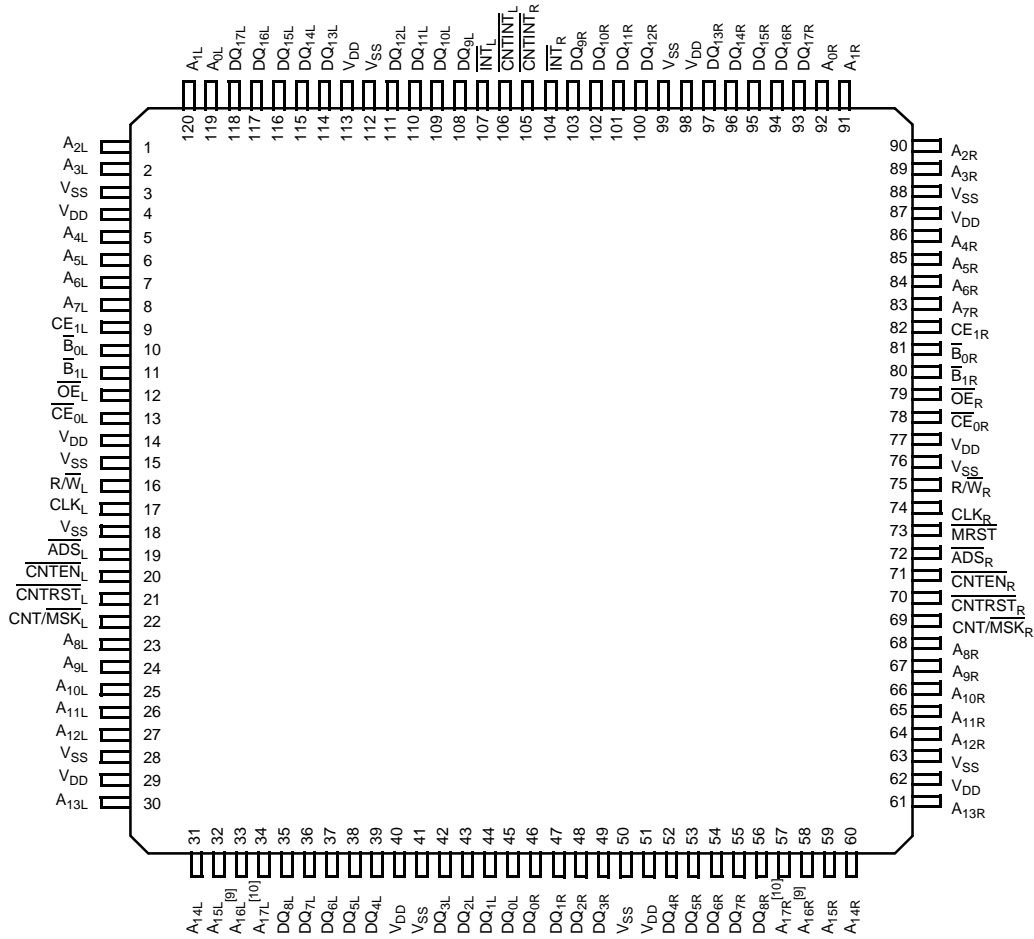

Notes:

- 9. Leave this pin unconnected for CY7C0830V
- 10. Leave this pin unconnected for CY7C0830V and CY7C0831V

Pin Definitions

Left Port	Right Port	Description
$A_{0L}-A_{18L}^{[1]}$	$A_{0R}-A_{18R}^{[1]}$	Address Inputs.
$\overline{ADS}_L^{[7]}$	$\overline{ADS}_R^{[7]}$	Address Strobe Input. Used as an address qualifier. This signal should be asserted LOW for the part using the externally supplied address on the address pins and for loading this address into the burst address counter.
$CE_{0L}^{[7]}$	$CE_{0R}^{[7]}$	Active LOW Chip Enable Input.
$CE_{1L}^{[6]}$	$CE_{1R}^{[6]}$	Active HIGH Chip Enable Input.
CLK_L	CLK_R	Clock Signal. Maximum clock input rate is f_{MAX} .
$\overline{CNTEN}_L^{[7]}$	$\overline{CNTEN}_R^{[7]}$	Counter Enable Input. Asserting this signal LOW increments the burst address counter of its respective port on each rising edge of CLK. The increment is disabled if ADS or CNTRST are asserted LOW.
$\overline{CNTRST}_L^{[6]}$	$\overline{CNTRST}_R^{[6]}$	Counter Reset Input. Asserting this signal LOW resets to zero the unmasked portion of the burst address counter of its respective port. CNTRST is not disabled by asserting ADS or CNTEN.
$CNT/\overline{MSK}_L^{[6]}$	$CNT/\overline{MSK}_R^{[6]}$	Address Counter Mask Register Enable Input. Asserting this signal LOW enables access to the mask register. When tied HIGH, the mask register is not accessible and the address counter operations are enabled based on the status of the counter control signals.
$DQ_{0L}-DQ_{17L}^{[1]}$	$DQ_{0R}-DQ_{17R}^{[1]}$	Data Bus Input/Output.
\overline{OE}_L	\overline{OE}_R	Output Enable Input. This asynchronous signal must be asserted LOW to enable the DQ data pins during Read operations.
\overline{INT}_L	\overline{INT}_R	Mailbox Interrupt Flag Output. The mailbox permits communications between ports. The upper two memory locations can be used for message passing. \overline{INT}_L is asserted LOW when the right port writes to the mailbox location of the left port, and vice versa. An interrupt to a port is deasserted HIGH when it reads the contents of its mailbox.
$\overline{CNTINT}_L^{[8]}$	$\overline{CNTINT}_R^{[8]}$	Counter Interrupt Output. This pin is asserted LOW when the unmasked portion of the counter is incremented to all "1s."
R/\overline{W}_L	R/\overline{W}_R	Read/Write Enable Input. Assert this pin LOW to write to, or HIGH to Read from the dual port memory array.
$\overline{B}_{0L}-\overline{B}_{3L}$	$\overline{B}_{0R}-\overline{B}_{1R}$	Byte Select Inputs. Asserting these signals enables Read and Write operations to the corresponding bytes of the memory array.
\overline{MRST}		Master Reset Input. MRST is an asynchronous input signal and affects both ports. Asserting MRST LOW performs all of the reset functions as described in the text. A MRST operation is required at power-up.
TMS		JTAG Test Mode Select Input. It controls the advance of JTAG TAP state machine. State machine transitions occur on the rising edge of TCK.
TDI		JTAG Test Data Input. Data on the TDI input will be shifted serially into selected registers.
TCK		JTAG Test Clock Input.
TDO		JTAG Test Data Output. TDO transitions occur on the falling edge of TCK. TDO is normally three-stated except when captured data is shifted out of the JTAG TAP.
V_{SS}		Ground Inputs.
V_{DD}		Power Inputs.

Master Reset

The FLEx18 family devices undergo a complete reset by taking its MRST input LOW. The MRST input can switch asynchronously to the clocks. An MRST initializes the internal burst counters to zero, and the counter mask registers to all ones (completely unmasked). MRST also forces the Mailbox Interrupt (INT) flags and the Counter Interrupt (CNTINT) flags HIGH. MRST must be performed on the FLEx18 family devices after power-up.

Mailbox Interrupts

The upper two memory locations may be used for message passing and permit communications between ports. Table 2 shows the interrupt operation for both ports of CY7C0833V. The highest memory location, 7FFFF is the mailbox for the right port and 7FFFE is the mailbox for the left port. Table 2 shows that in order to set the INT_R flag, a Write operation by the left port to address 7FFFF will assert INT_R LOW. At least one byte has to be active for a Write to generate an interrupt. A valid Read of the 7FFFF location by the right port will reset INT_R HIGH. At least one byte has to be active in order for a Read to reset the interrupt. When one port Writes to the other port's mailbox, the INT of the port that the mailbox belongs to is asserted LOW. The INT is reset when the owner (port) of the mailbox Reads the contents of the mailbox. The interrupt flag is set in a flow-thru mode (i.e., it follows the clock edge of the writing port). Also, the flag is reset in a flow-thru mode (i.e., it follows the clock edge of the reading port).

Each port can read the other port's mailbox without resetting the interrupt. And each port can write to its own mailbox without setting the interrupt. If an application does not require message passing, INT pins should be left open.

Address Counter and Mask Register Operations^[15]

This section describes the features only apply to 512Kbit, 1Mbit, 2Mbit, and 4Mbit devices. It does not apply to 9Mbit device. Each port of these devices has a programmable burst address counter. The burst counter contains three registers: a counter register, a mask register, and a mirror register.

Table 2. Interrupt Operation Example ^[1,11,12,13,14,16]

FUNCTION	LEFT PORT				RIGHT PORT			
	R/W _L	CE _L	A _{0L} - A _{18L}	INT _L	R/W _R	CE _R	A _{0R} - A _{18R}	INT _R
Set Right INT _R Flag	L	L	3FFFF	X	X	X	X	L
Reset Right INT _R Flag	X	X	X	X	H	L	3FFFF	H
Set Left INT _L Flag	X	X	X	L	L	L	3FFFE	X
Reset Left INT _L Flag	H	L	3FFFE	H	X	X	X	X
Set Right INT _R Flag	L	L	3FFFF	X	X	X	X	L

Notes:

- CE is internal signal. CE = LOW if CE₀ = LOW and CE₁ = HIGH. For a single Read operation, CE only needs to be asserted once at the rising edge of the CLK and can be deasserted after that. Data will be out after the following CLK edge and will be three-stated after the next CLK edge.
- OE is "Don't Care" for mailbox operation.
- At least one of BE₀, BE₁ must be LOW.
- A18x is a NC for CY7C0832V, therefore the Interrupt Addresses are 3FFFF and 3FFFE. A18x and A17x are NC for CY7C0831V, therefore the Interrupt addresses are 1FFFF and 1FFFE; A18x, A17x and A16x are NC for CY7C0830V, therefore the Interrupt Addresses are FFFF and FFFE; A18x, A17x, A16x and A15x are NC for CY7C0837V, therefore the Interrupt Addresses are 7FFF and 7FFE.
- This section describes the CY7C0832V, CY7C0831V, CY7C0830V and CY7C0837V having 18, 17, 16 and 15 address bits.
- "X" = "Don't Care," "H" = HIGH, "L" = LOW.

The **counter register** contains the address used to access the RAM array. It is changed only by the Counter Load, Increment, Counter Reset, and by master reset (MRST) operations.

The **mask register** value affects the Increment and Counter Reset operations by preventing the corresponding bits of the counter register from changing. It also affects the counter interrupt output (CNTINT). The mask register is changed only by the Mask Load and Mask Reset operations, and by the MRST. The mask register defines the counting range of the counter register. It divides the counter register into two regions: zero or more "0s" in the most significant bits define the masked region, one or more "1s" in the least significant bits define the unmasked region. Bit 0 may also be "0," masking the least significant counter bit and causing the counter to increment by two instead of one.

The **mirror register** is used to reload the counter register on increment operations (see "retransmit," below). It always contains the value last loaded into the counter register, and is changed only by the Counter Load, and Counter Reset operations, and by the MRST. Table 3 summarizes the operation of these registers and the required input control signals. The MRST control signal is asynchronous. All the other control signals in Table 3 (CNT/MSK, CNTRST, ADS, CNTEN) are synchronized to the port's CLK. All these counter and mask operations are independent of the port's chip enable inputs (CE₀ and CE₁).

Counter enable (CNTEN) inputs are provided to stall the operation of the address input and utilize the internal address generated by the internal counter for fast, interleaved memory applications. A port's burst counter is loaded when the port's address strobe (ADS) and CNTEN signals are LOW. When the port's CNTEN is asserted and the ADS is deasserted, the address counter will increment on each LOW to HIGH transition of that port's clock signal. This will Read/Write one word from/into each successive address location until CNTEN is deasserted. The counter can address the entire memory array, and will loop back to the start. Counter reset (CNTRST) is used to reset the unmasked portion of the burst counter to i0s. A counter-mask register is used to control the counter wrap.

Counter Reset Operation

All unmasked bits of the counter and mirror registers are reset to "0." All masked bits remain unchanged. A Mask Reset followed by a Counter Reset will reset the counter and mirror registers to 00000, as will master reset (MRST).

Counter Load Operation

The address counter and mirror registers are both loaded with the address value presented at the address lines.

Counter Increment Operation

Once the address counter register is initially loaded with an external address, the counter can internally increment the address value, potentially addressing the entire memory array. Only the unmasked bits of the counter register are incremented. The corresponding bit in the mask register must be a "1" for a counter bit to change. The counter register is incremented by 1 if the least significant bit is unmasked, and by 2 if it is masked. If all unmasked bits are "1," the next increment will wrap the counter back to the initially loaded value. If an Increment results in all the unmasked bits of the counter being "1s," a counter interrupt flag (CNTINT) is asserted. The next Increment will return the counter register to its initial value, which was stored in the mirror register. The counter address can instead be forced to loop to 00000 by externally connecting CNTINT to CNTRST.^[18] An increment that results in one or more of the unmasked bits of the counter being "0" will de-assert the counter interrupt flag. The example in *Figure 2* shows the counter mask register loaded with a mask value of 0003Fh unmasking the first 6 bits with bit "0" as the LSB and bit "16" as the MSB. The maximum value the mask register can be loaded with is 3FFFFh. Setting the mask register to this value allows the counter to access the entire memory space. The address counter is then loaded with an

initial value of 8h. The base address bits (in this case, the 6th address through the 16th address) are loaded with an address value but do not increment once the counter is configured for increment operation. The counter address will start at address 8h. The counter will increment its internal address value till it reaches the mask register value of 3Fh. The counter wraps around the memory block to location 8h at the next count. CNTINT is issued when the counter reaches its maximum value

Counter Hold Operation

The value of all three registers can be constantly maintained unchanged for an unlimited number of clock cycles. Such operation is useful in applications where wait states are needed, or when address is available a few cycles ahead of data in a shared bus interface.









Counter Interrupt

The counter interrupt (CNTINT) is asserted LOW when an increment operation results in the unmasked portion of the counter register being all "1s." It is deasserted HIGH when an Increment operation results in any other value. It is also de-asserted by Counter Reset, Counter Load, Mask Reset and Mask Load operations, and by MRST.

Counter Readback Operation

The internal value of the counter register can be read out on the address lines. Readback is pipelined; the address will be valid t_{CA2} after the next rising edge of the port's clock. If address readback occurs while the port is enabled (CE0 LOW and CE1 HIGH), the data lines (DQs) will be three-stated. *Figure 1* shows a block diagram of the operation.

Table 3. Address Counter and Counter-Mask Register Control Operation (Any Port) ^[16, 17]

CLK	MRST	CNT/MSK	CNTRST	ADS	CNTEN	Operation	Description
X	L	X	X	X	X	Master Reset	Reset address counter to all 0s and mask register to all 1s.
	H	H	L	X	X	Counter Reset	Reset counter unmasked portion to all 0s.
	H	H	H	L	L	Counter Load	Load counter with external address value presented on address lines.
	H	H	H	L	H	Counter Readback	Read out counter internal value on address lines.
	H	H	H	H	L	Counter Increment	Internally increment address counter value.
	H	H	H	H	H	Counter Hold	Constantly hold the address value for multiple clock cycles.
	H	L	L	X	X	Mask Reset	Reset mask register to all 1s.
	H	L	H	L	L	Mask Load	Load mask register with value presented on the address lines.
	H	L	H	L	H	Mask Readback	Read out mask register value on address lines.
	H	L	H	H	X	Reserved	Operation undefined

Notes:

- Counter operation and mask register operation is independent of chip enables.
- CNTINT and CNTRST specs are guaranteed by design to operate properly at speed grade operating frequency when tied together.



Retransmit

Retransmit is a feature that allows the Read of a block of memory more than once without the need to reload the initial address. This eliminates the need for external logic to store and route data. It also reduces the complexity of the system design and saves board space. An internal “mirror register” is used to store the initially loaded address counter value. When the counter unmasked portion reaches its maximum value set by the mask register, it wraps back to the initial value stored in this “mirror register.” If the counter is continuously configured in increment mode, it increments again to its maximum value and wraps back to the value initially stored into the “mirror register.” Thus, the repeated access of the same data is allowed without the need for any external logic.

Mask Reset Operation

The mask register is reset to all “1s,” which unmask every bit of the counter. Master reset (MRST) also resets the mask register to all “1s.”

Mask Load Operation

The mask register is loaded with the address value presented at the address lines. Not all values permit correct increment

operations. Permitted values are of the form $2^n - 1$ or $2^n - 2$. From the most significant bit to the least significant bit, permitted values have zero or more “0s,” one or more “1s,” or one “0.” Thus 3FFFF, 003FE, and 00001 are permitted values, but 3F0FF, 003FC, and 00000 are not.

Mask Readback Operation

The internal value of the mask register can be read out on the address lines. Readback is pipelined; the address will be valid t_{CM2} after the next rising edge of the port's clock. If mask readback occurs while the port is enabled (CE0 LOW and CE1 HIGH), the data lines (DQs) will be three-stated. *Figure 1* shows a block diagram of the operation.

Counting by Two

When the least significant bit of the mask register is “0,” the counter increments by two. This may be used to connect the x18 devices as a 36-bit single port SRAM in which the counter of one port counts even addresses and the counter of the other port counts odd addresses. This even-odd address scheme stores one half of the 36-bit data in even memory locations, and the other half in odd memory locations.

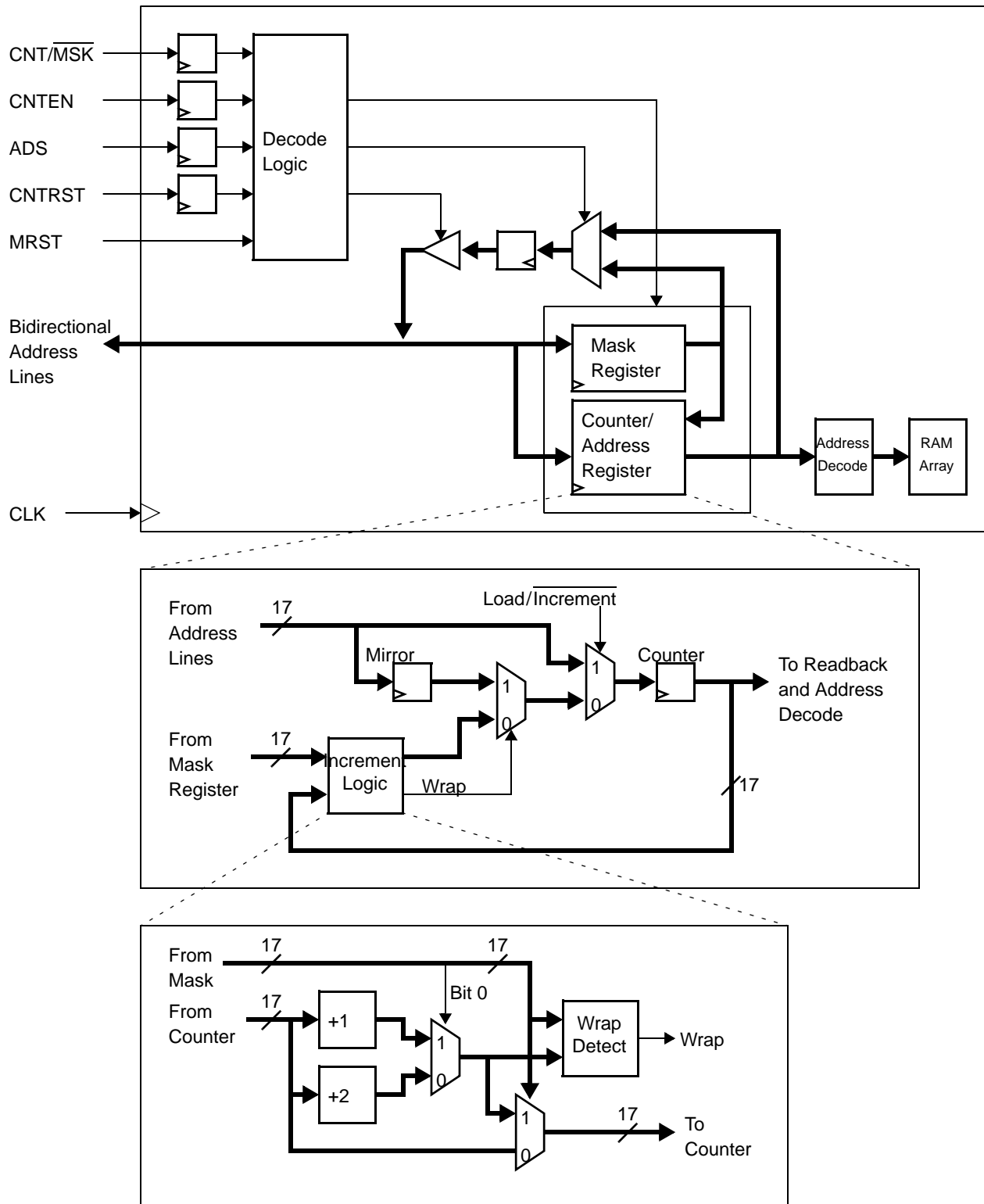

Figure 1. Counter, Mask, and Mirror Logic Block Diagram^[1]

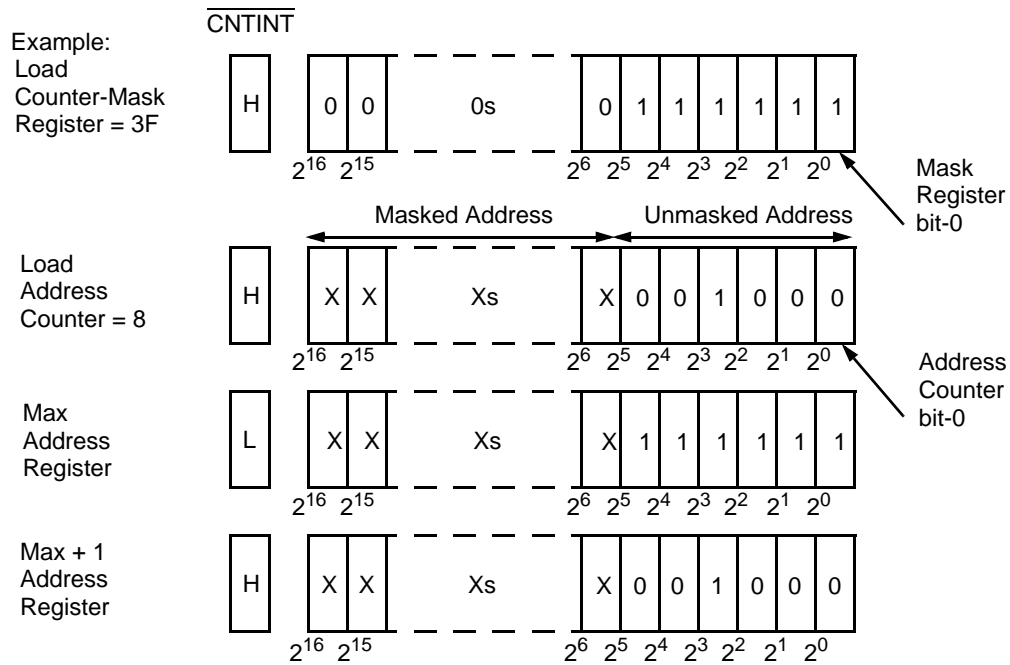

Figure 2. Programmable Counter-Mask Register Operation^[1, 19]

IEEE 1149.1 Serial Boundary Scan (JTAG)^[20]

The FLE_x18 family devices incorporate an IEEE 1149.1 serial boundary scan test access port (TAP). The TAP controller functions in a manner that does not conflict with the operation of other devices using 1149.1-compliant TAPs. The TAP operates using JEDEC-standard 3.3V I/O logic levels. It is composed of three input connections and one output connection required by the test logic defined by the standard.

Performing a TAP Reset

A reset is performed by forcing TMS HIGH (V_{DD}) for five rising edges of TCK. This reset does not affect the operation of the devices, and may be performed while the device is operating. An MRST must be performed on the devices after power-up.

Performing a Pause/Restart

When a SHIFT-DR PAUSE-DR SHIFT-DR is performed the scan chain will output the next bit in the chain twice. For example, if the value expected from the chain is 1010101, the device will output a 11010101. This extra bit will cause some testers to report an erroneous failure for the devices in a scan test. Therefore the tester should be configured to never enter the PAUSE-DR state.

Boundary Scan Hierarchy for 9-Mbit Device

Internally, the CY7C0833V have two DIEs. Each DIE contain all the circuitry required to support boundary scan testing. The circuitry includes the TAP, TAP controller, instruction register, and data registers. The circuitry and operation of the DIE boundary scan are described in detail below. The scan chain of each DIE are connected serially to form the scan chain of the CY7C0833V as shown in Figure 3. TMS and TCK are connected in parallel to each DIE to drive all TAP controllers in unison. In many cases, each DIE will be supplied with the same instruction. In other cases, it might be useful to supply different instructions to each DIE. One example would be testing the device ID of one DIE while bypassing the others.

Each pin of FLE_x18 family is typically connected to multiple DIEs. For connectivity testing with the EXTEST instruction, it is desirable to check the internal connections between DIEs as well as the external connections to the package. This can be accomplished by merging the netlist of the devices with the netlist of the user's circuit board. To facilitate boundary scan testing of the devices, Cypress provides the BSDL file for each DIE, the internal netlist of the device, and a description of the device scan chain. The user can use these materials to easily integrate the devices into the board's boundary scan environment. Further information can be found in the Cypress application note *Using JTAG Boundary Scan For System in a Package (SIP) Dual-Port SRAMs*.

Notes:

- 19. The "X" in this diagram represents the counter upper bits
- 20. Boundary scan is IEEE 1149.1-compatible. See "Performing a Pause/Restart" for deviation from strict 1149.1 compliance

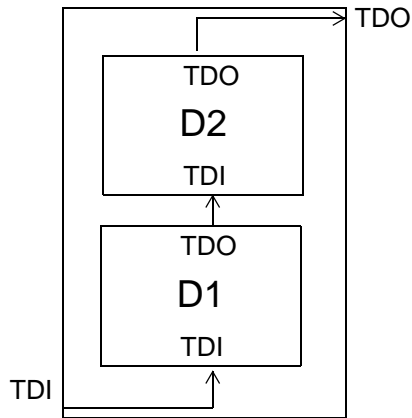
Figure 3. Scan Chain for 9Mb Device
Table 4. Identification Register Definitions

Instruction Field	Value	Description
Revision Number (31:28)	0h	Reserved for version number.
Cypress Device ID (27:12)	C090h	Defines Cypress part number for CY7C0832V
	C091h	Defines Cypress part number for CY7C0831V
	C093h	Defines Cypress part number for CY7C0830V
	C094h	Defines Cypress part number for CY7C0837V.
Cypress JEDEC ID (11:1)	034h	Allows unique identification of the DP family device vendor.
ID Register Presence (0)	1	Indicates the presence of an ID register.

Table 5. Scan Registers Sizes

Register Name	Bit Size
Instruction	4
Bypass	1
Identification	32
Boundary Scan	n ^[21]

Table 6. Instruction Identification Codes

Instruction	Code	Description
EXTEST	0000	Captures the Input/Output ring contents. Places the BSR between the TDI and TDO.
BYPASS	1111	Places the BYR between TDI and TDO.
IDCODE	1011	Loads the IDR with the vendor ID code and places the register between TDI and TDO.
HIGHZ	0111	Places BYR between TDI and TDO. Forces all device output drivers to a High-Z state.
CLAMP	0100	Controls boundary to 1/0. Places BYR between TDI and TDO.
SAMPLE/PRELOAD	1000	Captures the input/output ring contents. Places BSR between TDI and TDO.
NBSRST	1100	Resets the non-boundary scan logic. Places BYR between TDI and TDO.
RESERVED	All other codes	Other combinations are reserved. Do not use other than the above.

Notes:

21. See details in the device BSDL file.



PRELIMINARY

**CY7C0837V
CY7C0830V/CY7C0831V
CY7C0832V/CY7C0833V**

Maximum Ratings [22]

(Above which the useful life may be impaired. For user guidelines, not tested.)

Storage Temperature -65°C to +150°C
Ambient Temperature with
Power Applied -55°C to +125°C
Supply Voltage to Ground Potential -0.5V to +4.6V
DC Voltage Applied to
Outputs in High-Z State -0.5V to $V_{DD} + 0.5V$

DC Input Voltage -0.5V to $V_{DD} + 0.5V$ [23]
Output Current into Outputs (LOW) 20 mA
Static Discharge Voltage > 2000V
(JEDEC JESD22-A114-2000B)
Latch-up Current > 200 mA

Operating Range

Range	Ambient Temperature	V_{DD}
Commercial	0°C to +70°C	3.3V±165 mV
Industrial	-40°C to +85°C	3.3V±165 mV

Electrical Characteristics Over the Operating Range

Parameter	Description	-167			-133			-100			Unit
		Min.	Typ.	Max.	Min.	Typ.	Max.	Min.	Typ.	Max.	
V_{OH}	Output HIGH Voltage ($V_{DD} = \text{Min.}, I_{OH} = -4.0 \text{ mA}$)	2.4			2.4			2.4			V
V_{OL}	Output LOW Voltage ($V_{DD} = \text{Min.}, I_{OL} = +4.0 \text{ mA}$)			0.4				0.4		0.4	V
V_{IH}	Input HIGH Voltage	2.0			2.0			2.0			V
V_{IL}	Input LOW Voltage			0.8				0.8		0.8	V
I_{OZ}	Output Leakage Current	-10		10	-10		10	-10		10	mA
I_{IX1}	Input Leakage Current Except TDI, TMS, MRST	-10		10	-10		10	-10		10	mA
I_{IX2}	Input Leakage Current TDI, TMS, MRST	-0.1		1.0	-0.1		1.0	-0.1		1.0	mA
I_{CC}	Operating Current for ($V_{DD} = \text{Max.}, I_{OUT} = 0 \text{ mA}$), Outputs Disabled	CY7C0837V CY7C0830V CY7C0831V CY7C0832V		225	300		225	300			mA
		CY7C0833V					270	400		200	310
I_{SB1} [24]	Standby Current (Both Ports TTL Level) CE_L and $CE_R \hat{S} V_{IH}, f = f_{MAX}$		90	115		90	115		90	115	mA
I_{SB2} [24]	Standby Current (One Port TTL Level) $CE_L CE_R \hat{S} V_{IH}, f = f_{MAX}$		160	210		160	210		160	210	mA
I_{SB3} [24]	Standby Current (Both Ports CMOS Level) CE_L and $CE_R \hat{S} V_{DD} - 0.2V, f = 0$		55	75		55	75		55	75	mA
I_{SB4} [24]	Standby Current (One Port CMOS Level) $CE_L CE_R \hat{S} V_{IH}, f = f_{MAX}$		160	210		160	210		160	210	mA

Capacitance [25]

Part Number	Parameter	Description	Test Conditions	Max.	Unit
CY7C0837V CY7C0830V CY7C0831V CY7C0832V	C_{IN}	Input Capacitance	$T_A = 25^\circ\text{C}, f = 1 \text{ MHz},$ $V_{DD} = 3.3V$	13	pF
	C_{OUT}	Output Capacitance		10	pF
CY7C0833V	C_{IN}	Input Capacitance		22	pF
	C_{OUT}	Output Capacitance		20	pF

Note:

- 22. The voltage on any input or I/O pin can not exceed the power pin during power-up.
- 23. Pulse width < 20 ns.
- 24. $I_{SB1}, I_{SB2}, I_{SB3}$ and I_{SB4} are not applicable for CY7C0833V because it can not be powered down by using chip enable pins.
- 25. C_{OUT} also references $C_{I/O}$

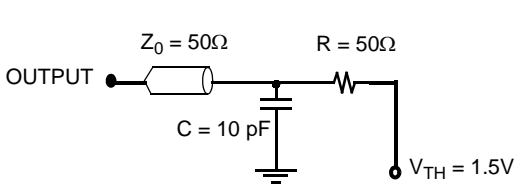
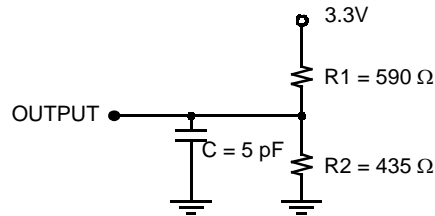
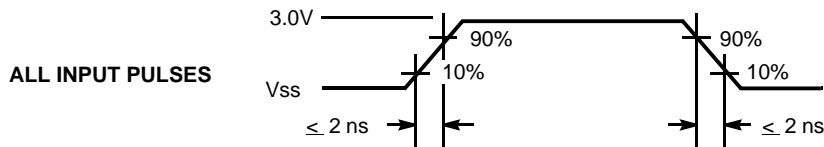
AC Test Load and Waveforms

(a) Normal Load (Load 1)

(b) Three-state Delay (Load 2)

Switching Characteristics Over the Operating Range

Parameter	Description	-167		-133				-100		Unit
		CY7C0837V CY7C0830V CY7C0831V CY7C0832V		CY7C0837V CY7C0830V CY7C0831V CY7C0832V		CY7C0833V		CY7C0833V		
		Min.	Max.	Min.	Max.	Min.	Max.	Min.	Max.	
f_{MAX2}	Maximum Operating Frequency		167		133		133		100	MHz
t_{CYC2}	Clock Cycle Time	6.0		7.5		7.5		10		ns
t_{CH2}	Clock HIGH Time	2.7		3.0		3.0		4.0		ns
t_{CL2}	Clock LOW Time	2.7		3.0		3.0		4.0		ns
$t_R^{[26]}$	Clock Rise Time		2.0		2.0		2.0		3.0	ns
$t_F^{[26]}$	Clock Fall Time		2.0		2.0		2.0		3.0	ns
t_{SA}	Address Set-up Time	2.3		2.5		2.5		3.0		ns
t_{HA}	Address Hold Time	0.6		0.6		0.6		0.6		ns
t_{SB}	Byte Select Set-up Time	2.3		2.5		2.5		3.0		ns
t_{HB}	Byte Select Hold Time	0.6		0.6		0.6		0.6		ns
t_{SC}	Chip Enable Set-up Time	2.3		2.5		NA		NA		ns
t_{HC}	Chip Enable Hold Time	0.6		0.6		NA		NA		ns
t_{SW}	R/W Set-up Time	2.3		2.5		2.5		3.0		ns
t_{HW}	R/W Hold Time	0.6		0.6		0.6		0.6		ns
t_{SD}	Input Data Set-up Time	2.3		2.5		2.5		3.0		ns
t_{HD}	Input Data Hold Time	0.6		0.6		0.6		0.6		ns
t_{SAD}	ADS Set-up Time	2.3		2.5		NA		NA		ns
t_{HAD}	ADS Hold Time	0.6		0.6		NA		NA		ns
t_{SCN}	CNTEN Set-up Time	2.3		2.5		NA		NA		ns
t_{HCN}	CNTEN Hold Time	0.6		0.6		NA		NA		ns
t_{SRST}	CNTRST Set-up Time	2.3		2.5		NA		NA		ns

Notes:

- 26. Except JTAG signals (t_r and $t_f < 10$ ns [max.]).
- 27. This parameter is guaranteed by design, but it is not production tested.
- 28. Test conditions used are Load 2.



PRELIMINARY

**CY7C0837V
CY7C0830V/CY7C0831V
CY7C0832V/CY7C0833V**

Switching Characteristics Over the Operating Range (continued)

Parameter	Description	-167		-133				-100		Unit
		CY7C0837V CY7C0830V CY7C0831V CY7C0832V		CY7C0837V CY7C0830V CY7C0831V CY7C0832V		CY7C0833V		CY7C0833V		
		Min.	Max.	Min.	Max.	Min.	Max.	Min.	Max.	
t _{HRST}	CNTRST Hold Time	0.6		0.6		NA		NA		ns
t _{SCM}	CNT/MSK Set-up Time	2.3		2.5		NA		NA		ns
t _{HCM}	CNT/MSK Hold Time	0.6		0.6		NA		NA		ns
t _{OE}	Output Enable to Data Valid		4.0		4.4		4.7		5.0	ns
t _{OLZ} ^[27,28]	OE to Low Z	0		0						ns
t _{OHZ} ^[27,28]	OE to High Z	0	4.0	0	4.4		4.7		5.0	ns
t _{CD2}	Clock to Data Valid		4.0		4.4		4.7		5.0	ns
t _{CA2}	Clock to Counter Address Valid		4.0		4.4		NA		NA	ns
t _{CM2}	Clock to Mask Register Readback Valid		4.0		4.4		NA		NA	ns
t _{DC}	Data Output Hold After Clock HIGH	1.0		1.0		1.0		1.0		ns
t _{CKHZ} ^[27,28]	Clock HIGH to Output High Z	0	4.0	0	4.4		4.7		5.0	ns
t _{CKLZ} ^[27,28]	Clock HIGH to Output Low Z	1.0	4.0	1.0	4.4	1.0	4.7	1.0	5.0	ns
t _{SINT}	Clock to INT Set Time	0.5	6.7	0.5	7.5	0.5	7.5	0.5	10	ns
t _{RINT}	Clock to INT Reset Time	0.5	6.7	0.5	7.5	0.5	7.5	0.5	10	ns
t _{SCINT}	Clock to CNTINT Set Time	0.5	5.0	0.5	5.7	NA	NA	NA	NA	ns
t _{RCINT}	Clock to CNTINT Reset time	0.5	5.0	0.5	5.7	NA	NA	NA	NA	ns
Port to Port Delays										
t _{CCS}	Clock to Clock Skew	5.2		6.0		6.0		8.0		ns
Master Reset Timing										
t _{RS}	Master Reset Pulse Width	7.0		7.5		7.5		10		ns
t _{RS}	Master Reset Set-up Time	6.0		6.0		6.0		8.5		ns
t _{RSR}	Master Reset Recovery Time	6.0		7.5		7.5		10		ns
t _{RSF}	Master Reset to Outputs Inactive		6.0		6.5		6.5		8.0	ns
t _{RSCNTINT}	Master Reset to Counter Interrupt Flag Reset Time		5.8		7.0		NA		NA	ns

JTAG Timing and Switching Waveforms

Parameter	Description	CY7C0837V/CY7C0830V CY7C0831V/CY7C0832V CY7C0833V		Unit
		Min.	Max.	
f_{JTAG}	Maximum JTAG TAP Controller Frequency		10	MHz
t_{TCYC}	TCK Clock Cycle Time	100		ns
t_{TH}	TCK Clock HIGH Time	40		ns
t_{TL}	TCK Clock LOW Time	40		ns
t_{TMSS}	TMS Set-up to TCK Clock Rise	10		ns
t_{TMSH}	TMS Hold After TCK Clock Rise	10		ns
t_{TDIS}	TDI Set-up to TCK Clock Rise	10		ns
t_{TDIH}	TDI Hold After TCK Clock Rise	10		ns
t_{TDOV}	TCK Clock LOW to TDO Valid		30	ns
t_{TDOX}	TCK Clock LOW to TDO Invalid	0		ns

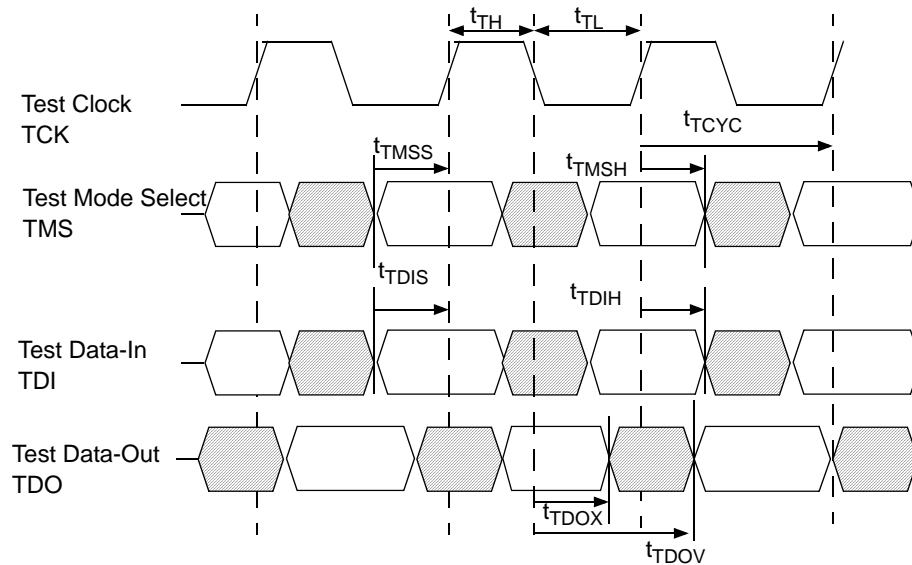

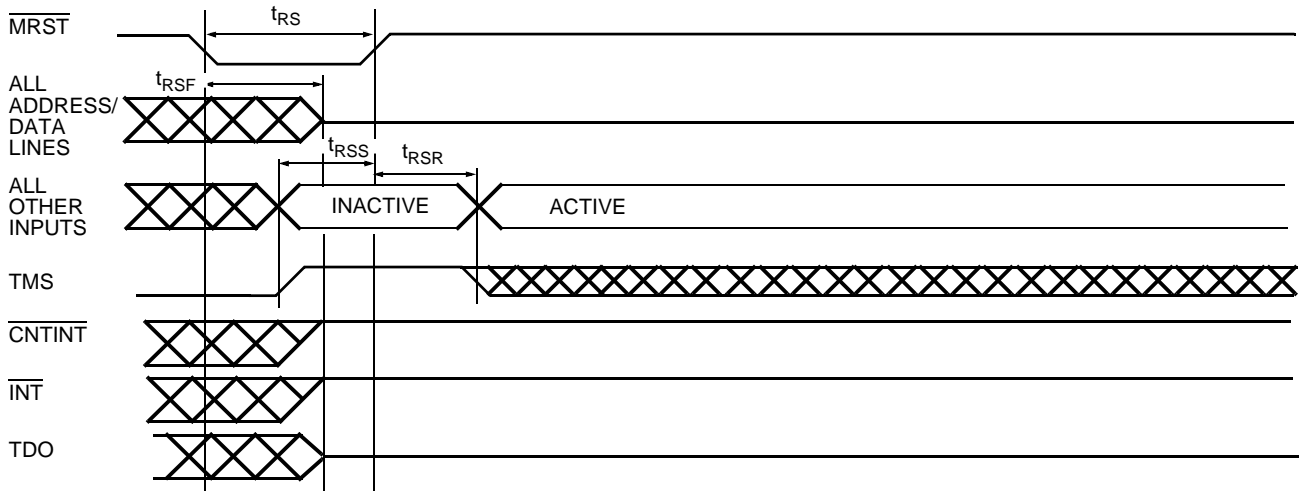
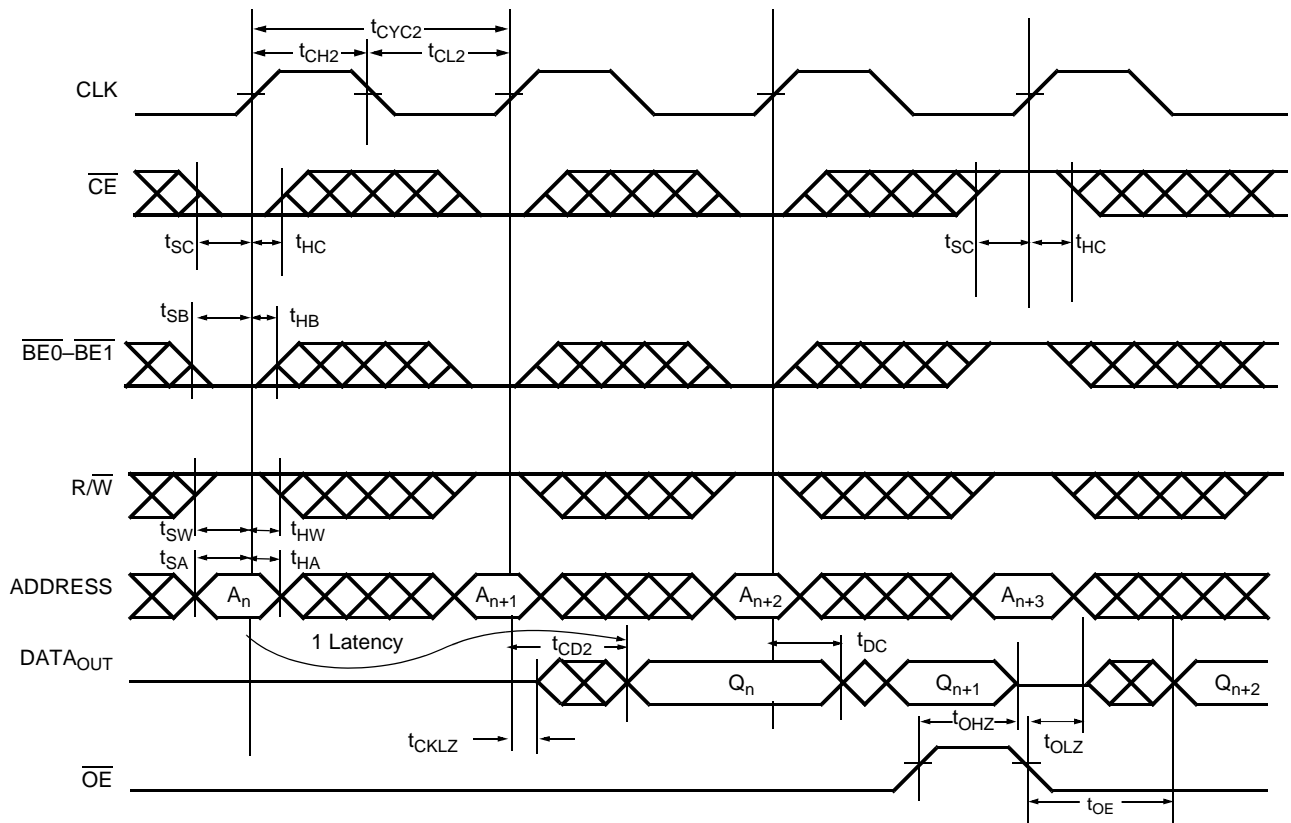
Switching Waveforms
Master Reset

Read Cycle^[11, 29, 30, 31, 32]

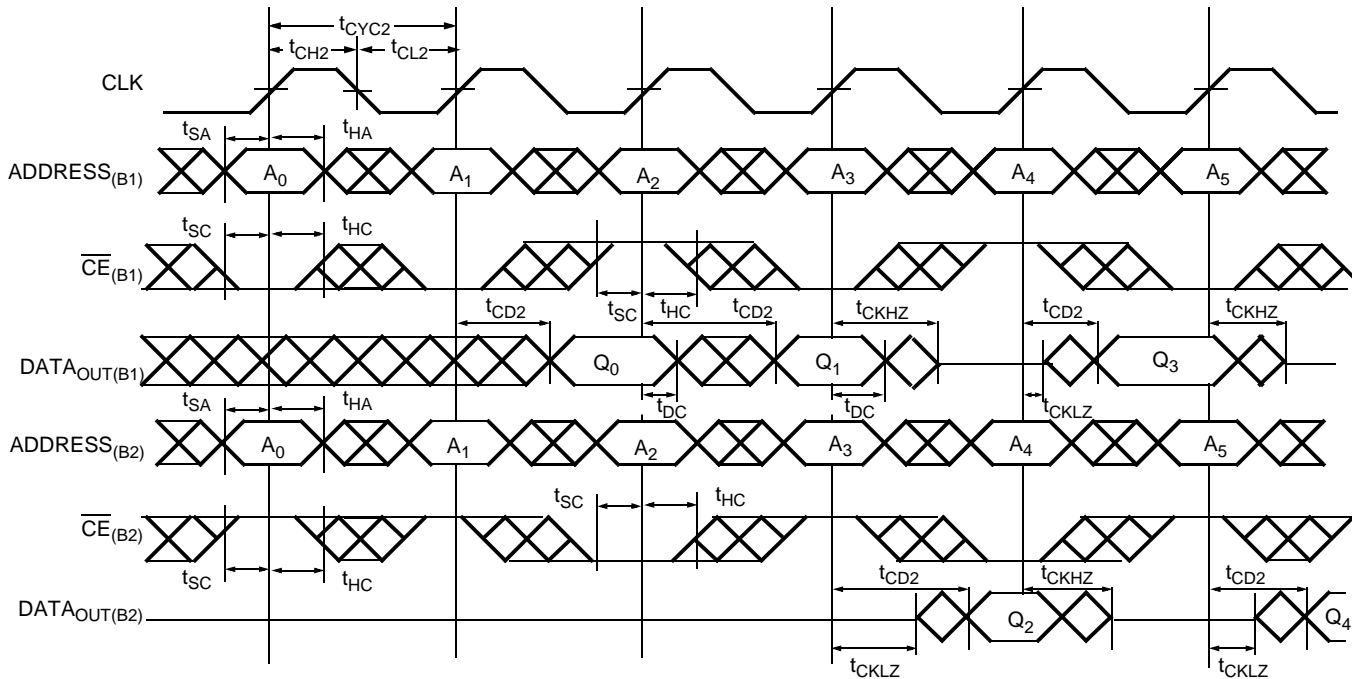
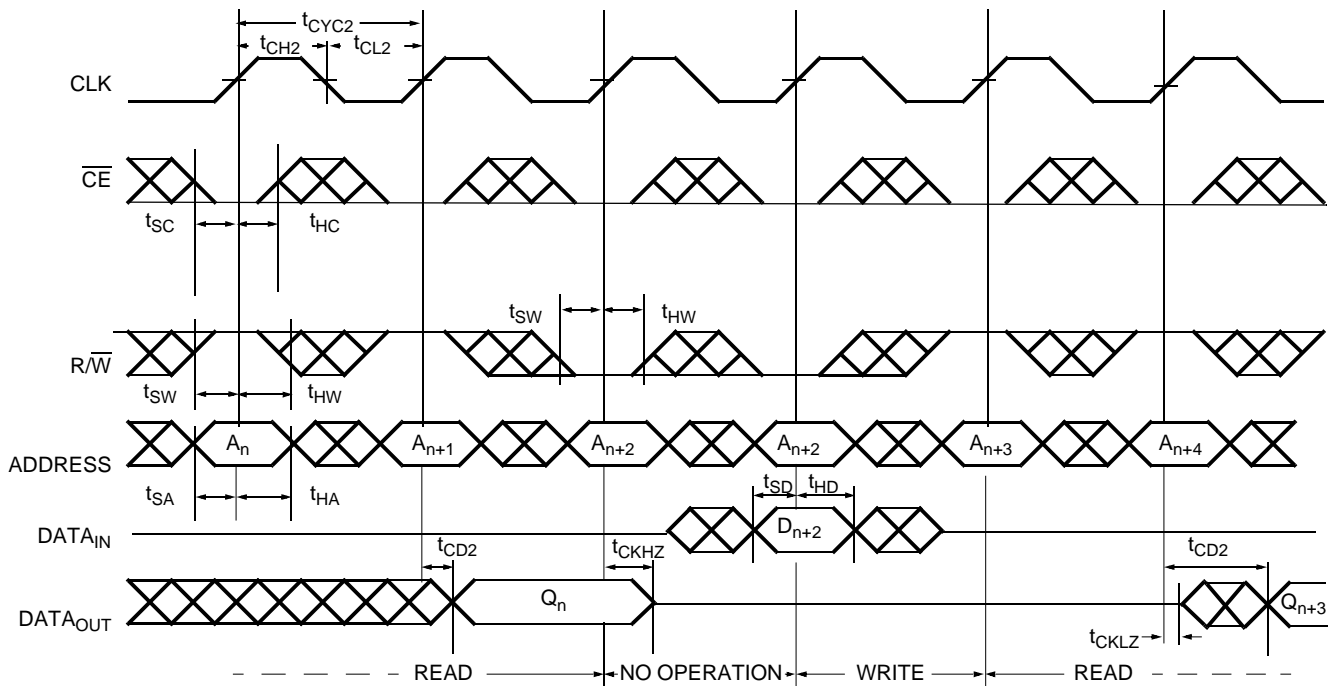
Notes:

29. \overline{OE} is asynchronously controlled; all other inputs (excluding \overline{MRST} and JTAG) are synchronous to the rising clock edge.
30. $ADS = CNTEN = LOW$, and $MRST = CNTRST = CNT/MSK = HIGH$.
31. The output is disabled (high-impedance state) by $CE = V_{IH}$ following the next rising edge of the clock.
32. Addresses do not have to be accessed sequentially since $ADS = CNTEN = V_{IL}$ with $CNT/MSK = V_{IH}$ constantly loads the address on the rising edge of the CLK. Numbers are for reference only.

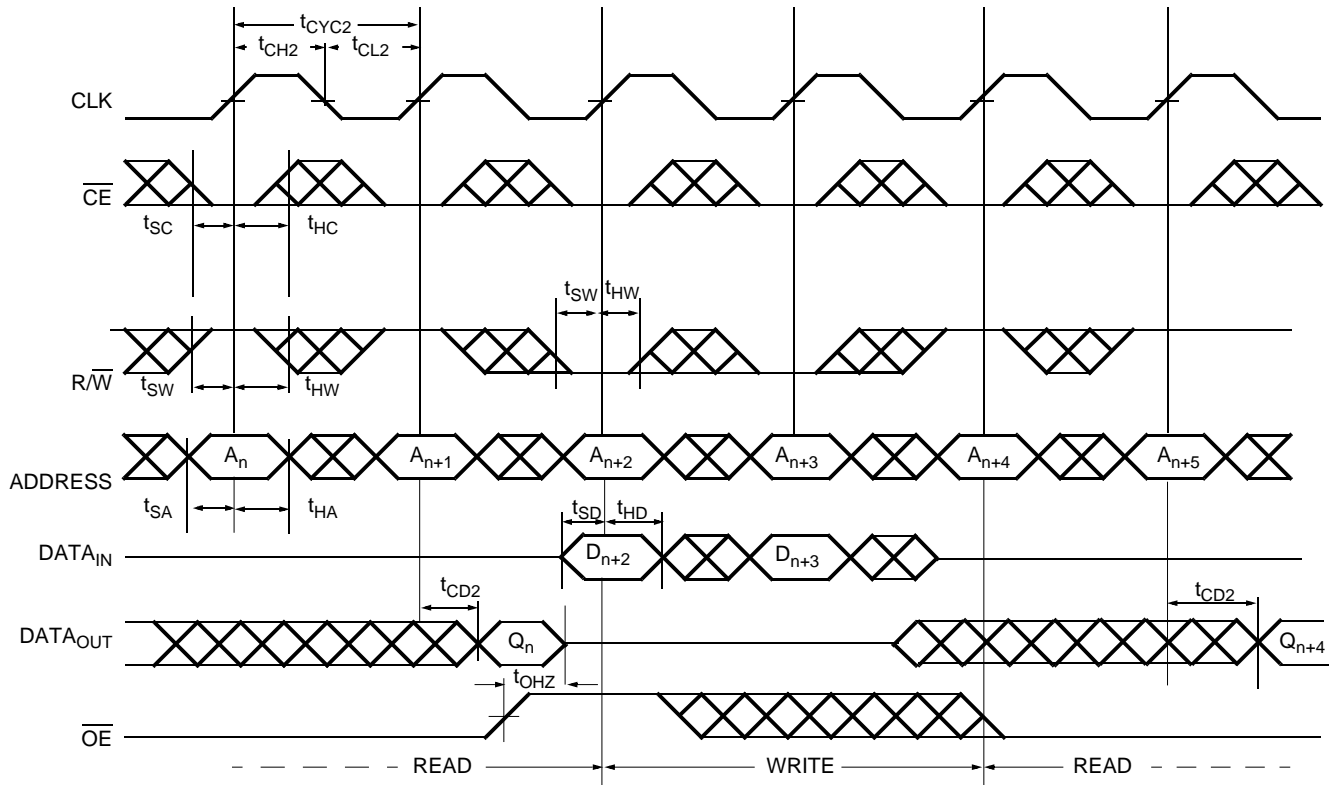
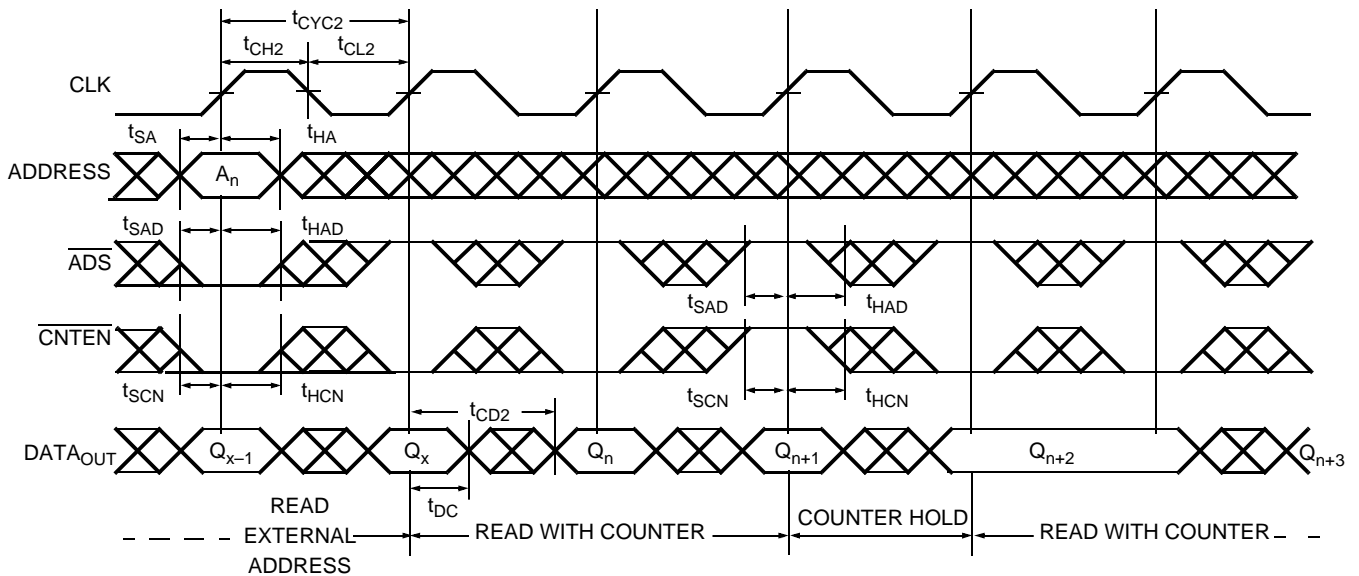
Switching Waveforms (continued)
Bank Select Read^[33, 34]

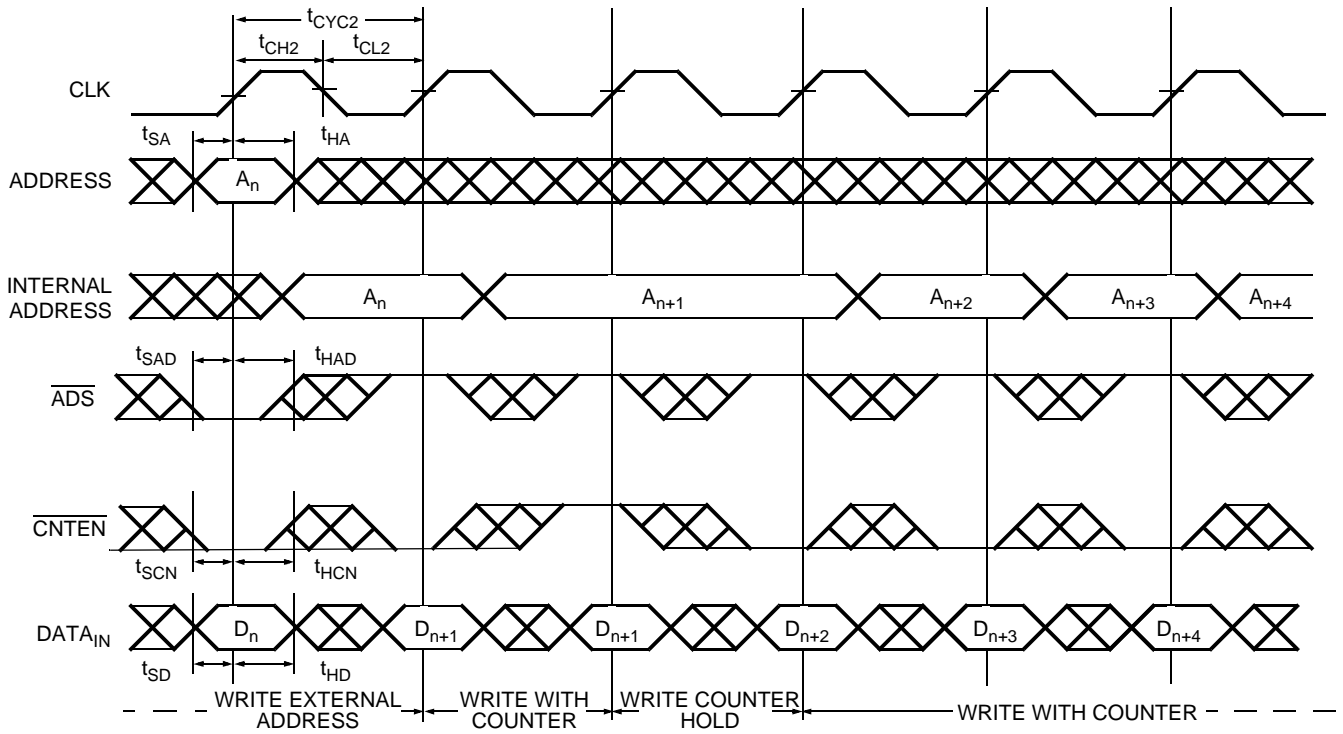
Read-to-Write-to-Read ($\overline{OE} = \text{LOW}$)^[32, 35, 36, 37, 38]

Notes:

33. In this depth-expansion example, B1 represents Bank #1 and B2 is Bank #2; each bank consists of one Cypress FLE_x18 device from this data sheet. ADDRESS_(B1) = ADDRESS_(B2).
34. $\overline{ADS} = \overline{CNTEN} = \overline{BE0} - \overline{BE1} = \overline{OE} = \text{LOW}$; $\overline{MRST} = \overline{CNTRST} = \overline{CNT/MSK} = \text{HIGH}$.
35. Output state (HIGH, LOW, or high-impedance) is determined by the previous cycle control signals.
36. During "No Operation," data in memory at the selected address may be corrupted and should be rewritten to ensure data integrity.
37. $\overline{CE}_0 = \overline{BE0} - \overline{BE1} = \text{LOW}$; $\overline{CE}_1 = \overline{R/W} = \overline{CNTRST} = \overline{MRST} = \text{HIGH}$.
38. $\overline{CE}_0 = \overline{BE0} - \overline{BE1} = \overline{R/W} = \text{LOW}$; $\overline{CE}_1 = \overline{CNTRST} = \overline{MRST} = \overline{CNT/MSK} = \text{HIGH}$. When $\overline{R/W}$ first switches low, since $\overline{OE} = \text{LOW}$, the Write operation cannot be completed (labelled as no operation). One clock cycle is required to three-state the I/O for the Write operation on the next rising edge of CLK.

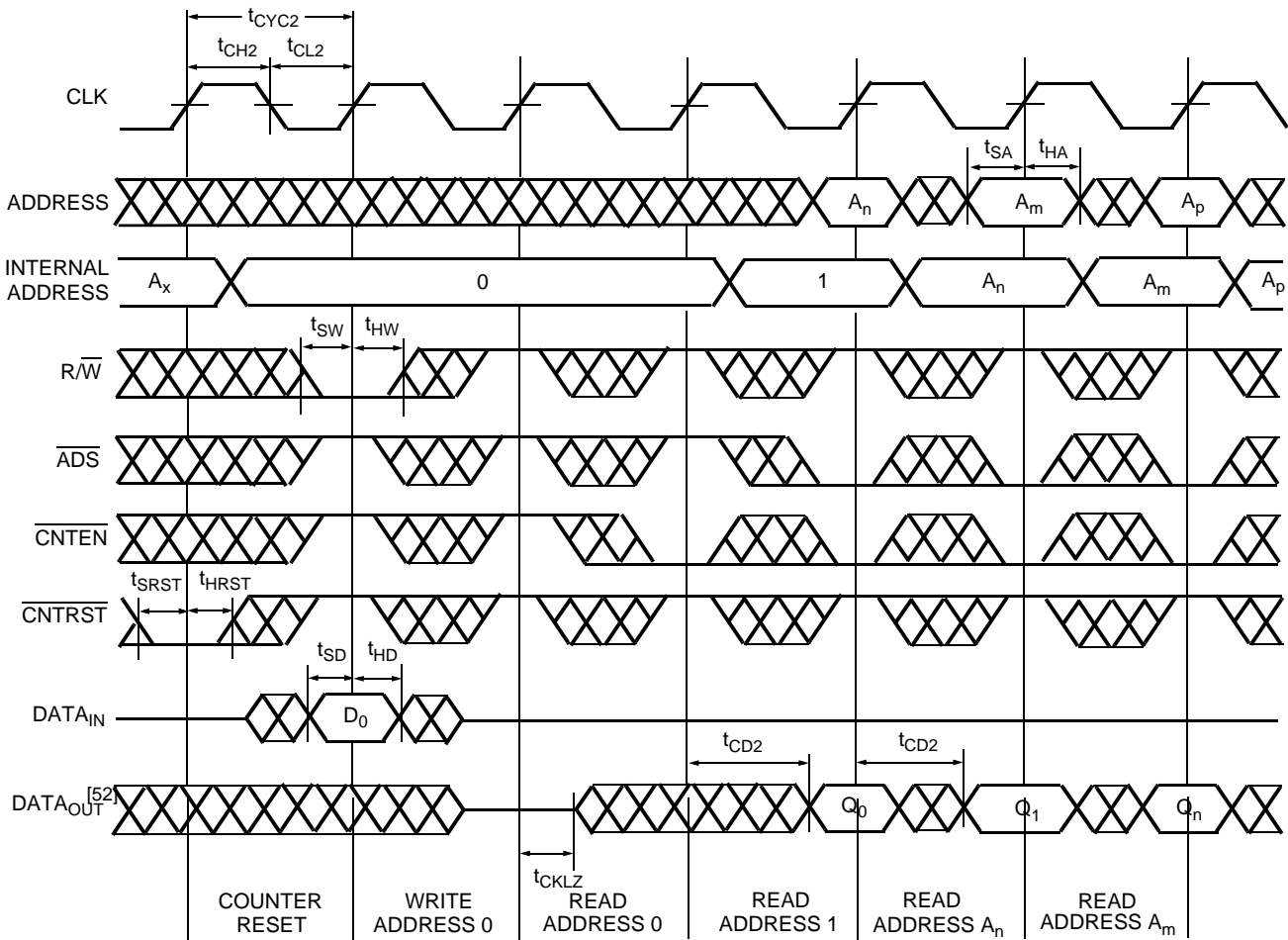
Switching Waveforms (continued)
Read-to-Write-to-Read (\overline{OE} Controlled)^[32, 35, 37, 38]

Read with Address Counter Advance^[37]

Switching Waveforms (continued)
Write with Address Counter Advance^[38]

Switching Waveforms (continued)
Counter Reset [39, 40]

Notes:

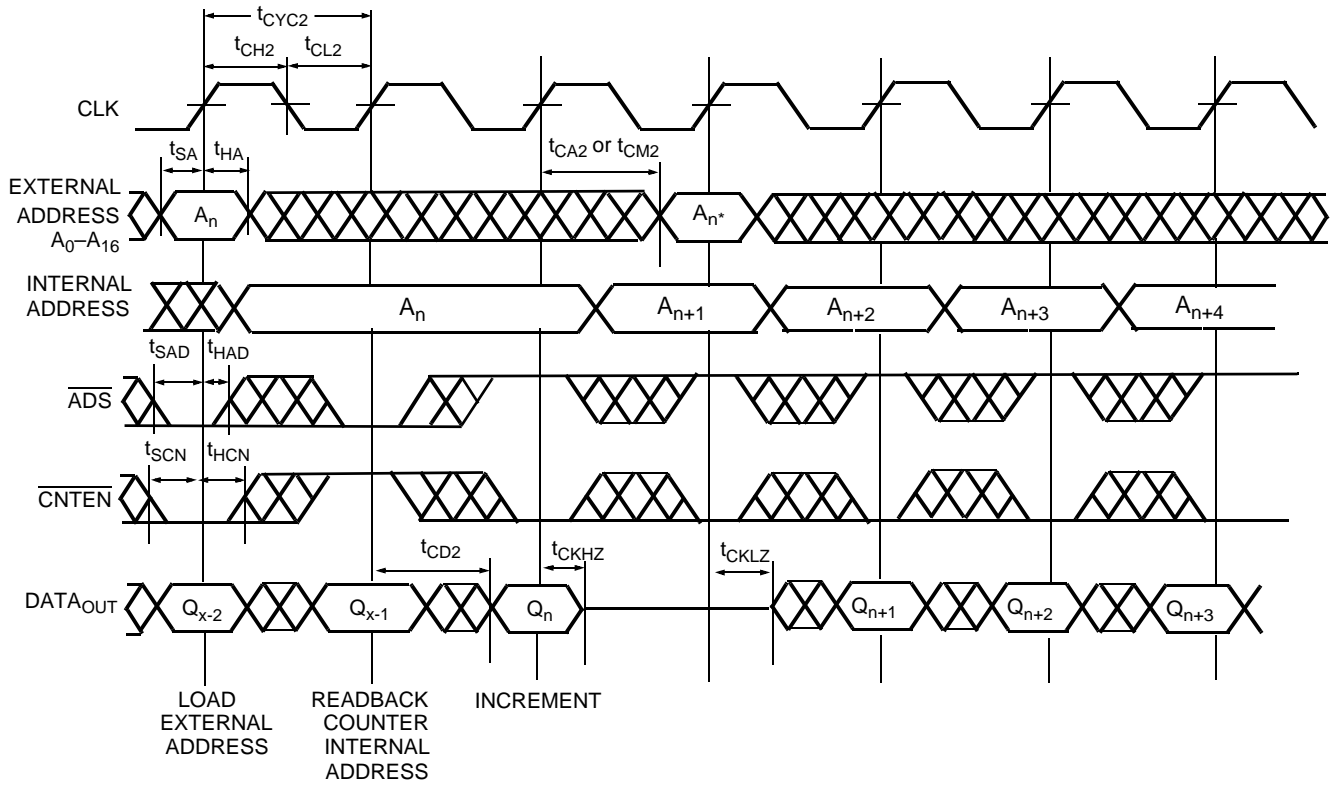
39. $\overline{CE}_0 = \overline{BE}_0 - \overline{BE}_1 = \text{LOW}$; $\overline{CE}_1 = \overline{MRST} = \text{CNT}/\overline{\text{MSK}} = \text{HIGH}$.

40. No dead cycle exists during counter reset. A Read or Write cycle may be coincidental with the counter reset.

Switching Waveforms (continued)
Readback State of Address Counter or Mask Register^[41, 42, 43, 44]

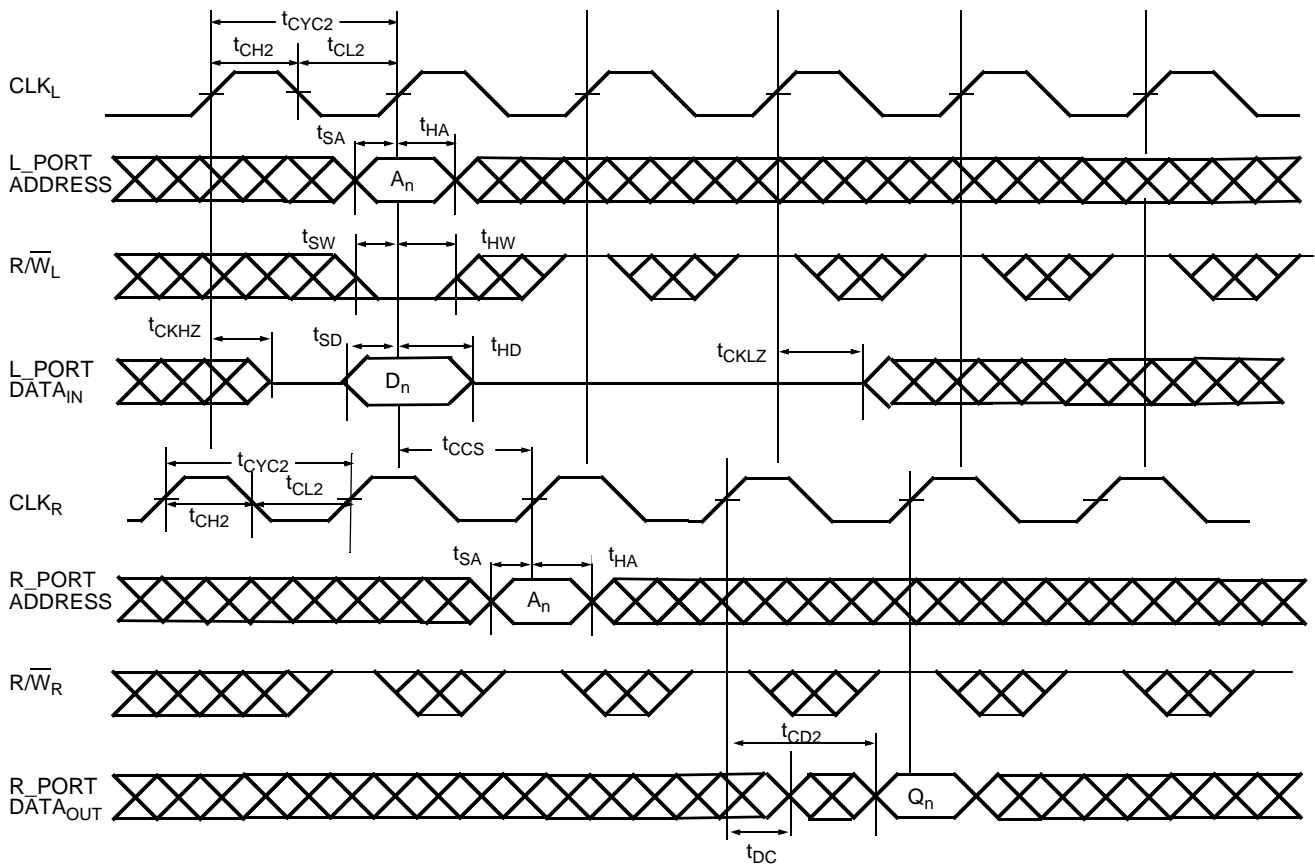
Notes:

41. $\overline{CE}_0 = \overline{OE} = \overline{BE}_0 - \overline{BE}_1 = \text{LOW}$; $CE_1 = R/\overline{W} = \overline{CNTRST} = \overline{MRST} = \text{HIGH}$.
42. Address in output mode. Host must not be driving address bus after t_{CKLZ} in next clock cycle.
43. Address in input mode. Host can drive address bus after t_{CKHZ}.
44. A_n * is the internal value of the address counter (or the mask register depending on the CNT/MSK level) being Read out on the address lines.

Switching Waveforms (continued)
Left_Port (L_Port) Write to Right_Port (R_Port) Read^[45, 46, 47]

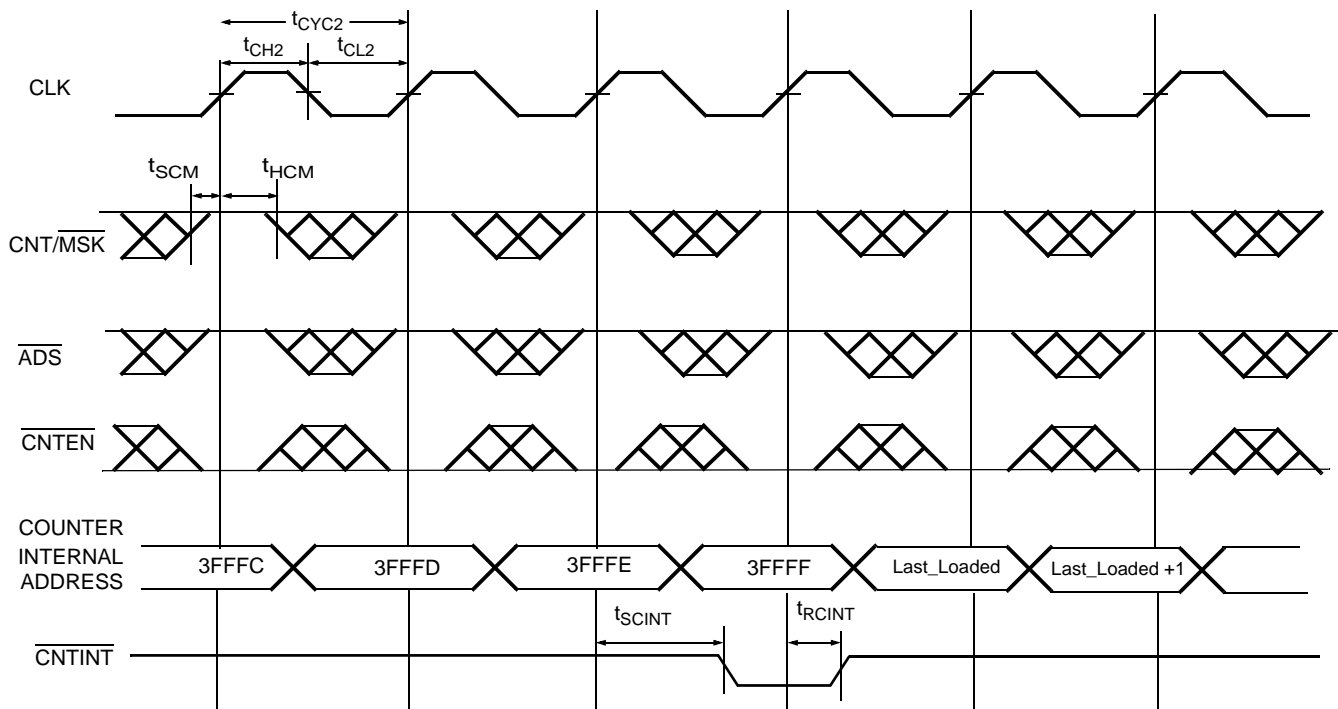
Notes:

45. $\overline{CE}_0 = \overline{OE} = \overline{ADS} = \overline{CNTEN} = \overline{BE0} - \overline{BE1} = \text{LOW}$; $CE_1 = \overline{CNTRST} = \overline{MRST} = \overline{CNT/MSK} = \text{HIGH}$.
46. This timing is valid when one port is writing, and other port is reading the same location at the same time. If t_{CCS} is violated, indeterminate data will be Read out.
47. If $t_{CCS} <$ minimum specified value, then R_Port will Read the most recent data (written by L_Port) only ($2 * t_{CYC2} + t_{CD2}$) after the rising edge of R_Port's clock. If $t_{CCS} \geq$ minimum specified value, then R_Port will Read the most recent data (written by L_Port) ($t_{CYC2} + t_{CD2}$) after the rising edge of R_Port's clock.

Switching Waveforms (continued)
Counter Interrupt and Retransmit^[14, 48, 49, 50, 51, 52]

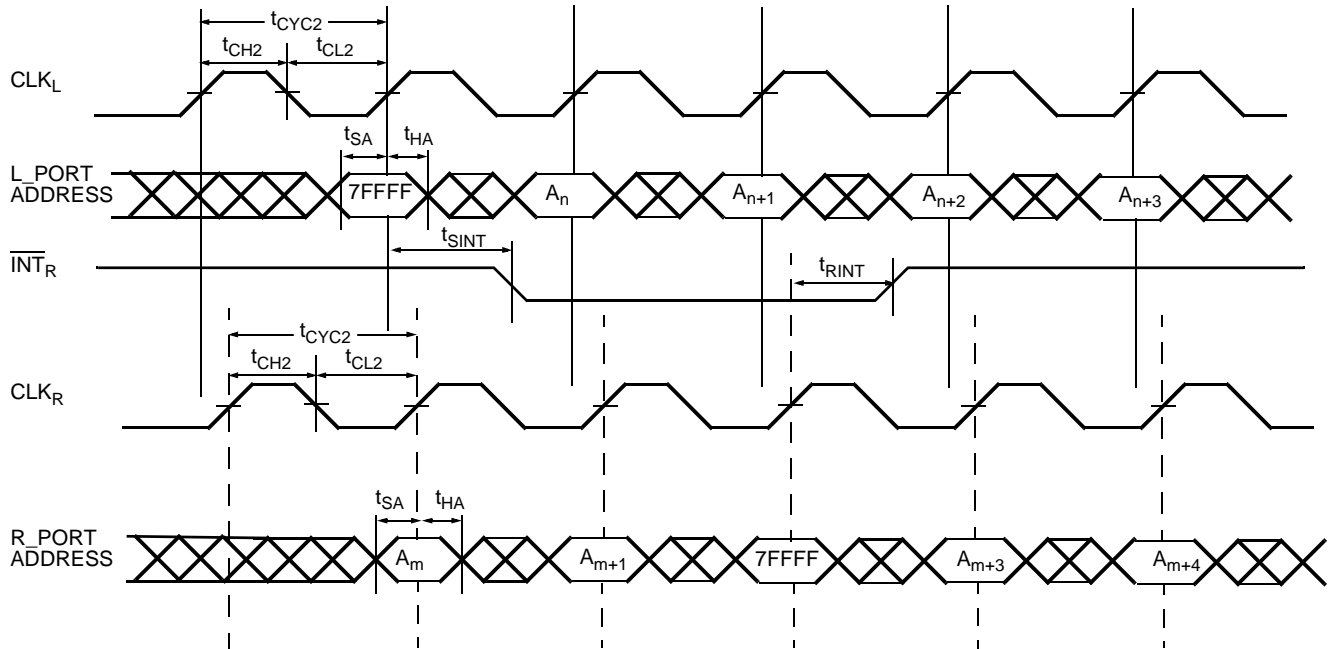
Notes:

48. $\overline{CE}_0 = \overline{OE} = \overline{BE}_0 - \overline{BE}_1 = \text{LOW}$; $\overline{CE}_1 = \overline{R/\overline{W}} = \overline{CNTRST} = \overline{MRST} = \text{HIGH}$.
49. \overline{CNTINT} is always driven.
50. \overline{CNTINT} goes LOW when the unmasked portion of the address counter is incremented to the maximum value.
51. The mask register assumed to have the value of 3FFFFh.
52. Retransmit happens if the counter remains in increment mode after it wraps to initially loaded value.

Switching Waveforms (continued)
MailBox Interrupt Timing^[53, 54, 55, 56, 57]

Table 7. Read/Write and Enable Operation (Any Port)^[1, 16, 58, 59, 60]

Inputs					Outputs	Operation
\overline{OE}	CLK	\overline{CE}_0	CE_1	R/W	DQ ₀ – DQ ₁₇	
X		H	X	X	High-Z	Deselected
X		X	L	X	High-Z	Deselected
X		L	H	L	D _{IN}	Write
L		L	H	H	D _{OUT}	Read
H	X	L	H	X	High-Z	Outputs Disabled

Notes:

53. $\overline{CE}_0 = \overline{OE} = \overline{ADS} = \overline{CNTEN} = \text{LOW}$; $CE_1 = \overline{CNTRST} = \overline{MRST} = \overline{CNT/MSK} = \text{HIGH}$.
54. Address "7FFFF" is the mailbox location for R_Port of the 9Mb device.
55. L_Port is configured for Write operation, and R_Port is configured for Read operation.
56. At least one byte enable (BE₀ – BE₁) is required to be active during interrupt operations.
57. Interrupt flag is set with respect to the rising edge of the Write clock, and is reset with respect to the rising edge of the Read clock.
58. OE is an asynchronous input signal.
59. When CE changes state, deselection and Read happen after one cycle of latency.
60. $CE_0 = OE = \text{LOW}$; $CE_1 = R/W = \text{HIGH}$.



PRELIMINARY

**CY7C0837V
CY7C0830V/CY7C0831V
CY7C0832V/CY7C0833V**

Ordering Information

512K x 18 (9-Mbit) 3.3V Synchronous CY7C0833V Dual-Port SRAM

Speed (MHz)	Ordering Code	Package Name	Package Type	Operating Range
133	CY7C0833V-133BBC	BB144	144-ball Grid Array 13 mm x 13 mm with 1.0 mm pitch (BGA)	Commercial
100	CY7C0833V-100BBC	BB144	144-ball Grid Array 13 mm x 13 mm with 1.0 mm pitch (BGA)	Commercial
	CY7C0833V-100BBI	BB144	144-ball Grid Array 13 mm x 13 mm with 1.0 mm pitch (BGA)	Industrial

256K x 18 (4-Mbit) 3.3V Synchronous CY7C0832V Dual-Port SRAM

Speed (MHz)	Ordering Code	Package Name	Package Type	Operating Range
167	CY7C0832V-167BBC	BB144	144-ball Grid Array 13 mm x 13 mm with 1.0 mm pitch (BGA)	Commercial
167	CY7C0832V-167AC	A120	120-pin Flat Pack 14mm x 14mm (TQFP)	Commercial
133	CY7C0832V-133BBC	BB144	144-ball Grid Array 13 mm x 13 mm with 1.0 mm pitch (BGA)	Commercial
	CY7C0832V-133BBI	BB144	144-ball Grid Array 13 mm x 13 mm with 1.0 mm pitch (BGA)	Industrial
133	CY7C0832V-133AC	A120	120-pin Flat Pack 14mm x 14mm (TQFP)	Commercial
	CY7C0832V-133AI	A120	120-pin Flat Pack 14mm x 14mm (TQFP)	Industrial

128K x 18 (2-Mbit) 3.3V Synchronous CY7C0831V Dual-Port SRAM

Speed (MHz)	Ordering Code	Package Name	Package Type	Operating Range
167	CY7C0831V-167BBC	BB144	144-ball Grid Array 13 mm x 13 mm with 1.0 mm pitch (BGA)	Commercial
167	CY7C0831V-167AC	A120	120-pin Flat Pack 14mm x 14mm (TQFP)	Commercial
133	CY7C0831V-167BBC	BB144	144-ball Grid Array 13 mm x 13 mm with 1.0 mm pitch (BGA)	Commercial
	CY7C0831V-167BBI	BB144	144-ball Grid Array 13 mm x 13 mm with 1.0 mm pitch (BGA)	Industrial
133	CY7C0831V-167AC	A120	120-pin Flat Pack 14mm x 14mm (TQFP)	Commercial
	CY7C0831V-167AI	A120	120-pin Flat Pack 14mm x 14mm (TQFP)	Industrial

64K x 18 (1-Mbit) 3.3V Synchronous CY7C0830V Dual-Port SRAM

Speed (MHz)	Ordering Code	Package Name	Package Type	Operating Range
167	CY7C0830V-167BBC	BB144	144-ball Grid Array 13 mm x 13 mm with 1.0 mm pitch (BGA)	Commercial
167	CY7C0830V-167AC	A120	120-pin Flat Pack 14mm x 14mm (TQFP)	Commercial
133	CY7C0830V-133BBC	BB144	144-ball Grid Array 13 mm x 13 mm with 1.0 mm pitch (BGA)	Commercial
	CY7C0830V-133BBI	BB144	144-ball Grid Array 13 mm x 13 mm with 1.0 mm pitch (BGA)	Industrial
133	CY7C0830V-133AC	A120	120-pin Flat Pack 14mm x 14mm (TQFP)	Commercial
	CY7C0830V-133AI	A120	120-pin Flat Pack 14mm x 14mm (TQFP)	Industrial

32K x 18 (512-Kbit) 3.3V Synchronous CY7C0837V Dual-Port SRAM

Speed (MHz)	Ordering Code	Package Name	Package Type	Operating Range
167	CY7C0837V-167BBC	BB144	144-ball Grid Array 13 mm x 13 mm with 1.0 mm pitch (BGA)	Commercial
133	CY7C0837V-133BBC	BB144	144-ball Grid Array 13 mm x 13 mm with 1.0 mm pitch (BGA)	Commercial
	CY7C0837V-133BBI	BB144	144-ball Grid Array 13 mm x 13 mm with 1.0 mm pitch (BGA)	Industrial

Package Diagram

144 FBGA (13 x 13 x 1.6 MM) BB144

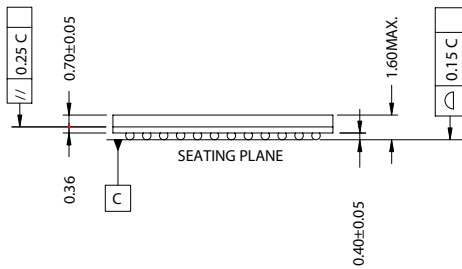
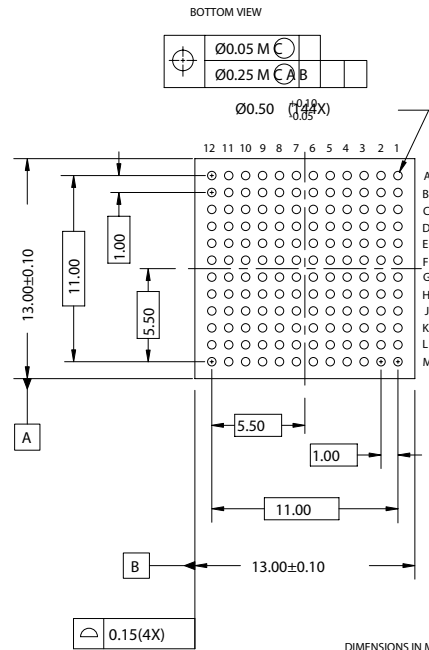
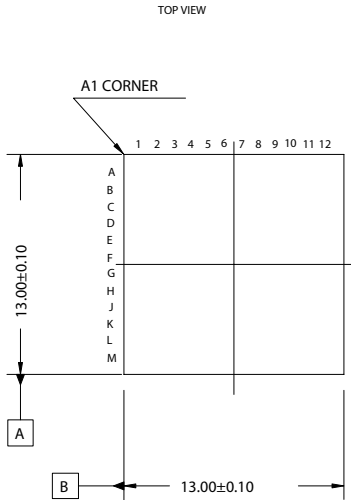

DIMENSIONS IN MILLIMETERS
REFERENCE JEDEC: PUBLICATION 95
DESIGN GUIDE 4.14D
PKG. WEIGHT: 0.53 gms

51-85141-*B

Package Diagrams (continued)

120-Pin Thin Quad Flatpack (14 x 14 x 1.4 mm) A120

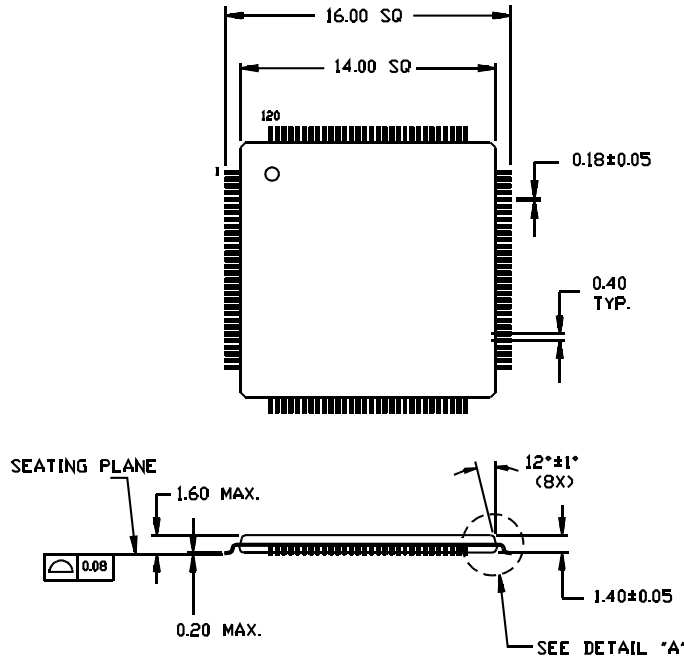

DIMENSIONS IN MILLIMETERS

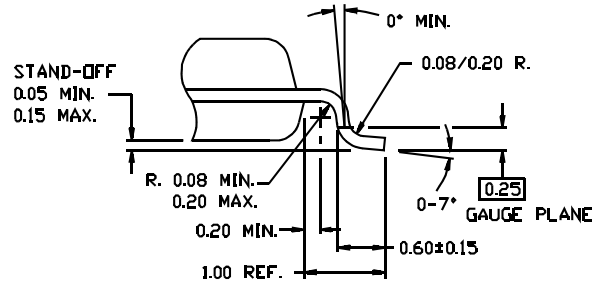

DETAIL "A"

51-85100.**

All product and company names mentioned in this document may be the trademarks of their respective holders.



PRELIMINARY

**CY7C0837V
CY7C0830V/CY7C0831V
CY7C0832V/CY7C0833V**

Document History Page

Document Title: FLEx18™ 3.3V 32K/64K/128K/256K/512K x 18 Synchronous Dual-Port RAM Document Number: 38-06059				
REV.	ECN NO.	Issue Date	Orig. of Change	Description of Change
**	111473	11/27/01	DSG	Change from Spec number: 38-01056 to 38-06059
*A	111942	12/21/01	JFU	Updated capacitance values Updated switching parameters and ISB3 Updated "Read-to-Write-to-Read (OE Controlled)" waveform Revised static discharge voltage Revised footnote regarding ISB3
*B	113741	04/02/02	KRE	Updated Isb values Updated ESD voltage Corrected 0853 pins L3 and L12
*C	114704	04/24/02	KRE	Added discussion of Pause/Restart for JTAG boundary scan
*D	115336	07/01/02	KRE	Revised speed offerings for all densities
*E	122307	12/27/02	RBI	Power up requirements added to Maximum Ratings Information
*F	123636	1/27/03	KRE	Revise tcd2, tOE, tOHZ, tCKHZ, tCKLZ for the CY7C0853V to 4.7 ns
*G	126053	08/11/03	SPN	Separated out 4M and 9M data sheets Updated Isb and ICC values
*H	129443	11/03/03	RAZ	Updated Isb and ICC values
*I	231993	See ECN	YDT	Removed "A particular port can write to a certain location while another port is reading that location." from Functional Description.
*J	231813	See ECN	WWZ	Removed x36 devices (CY7C0852/CY7C0851) from this datasheet. Added 0.5M, 1M and 9M x18 devices to it. Changed title to FLEx18 3.3V 32K/64K/128K/256K/512K x18 Synchronous Dual-Port RAM. Changed datasheet to accommodate the removals and additions. Removed general JTAG description. Updated JTAG ID codes for all devices. Added 144FBGA package for all devices. Updated selection guide table and moved to the front page. Updated block diagram to reflect x18 configuration. Added preliminary status back due to the addition of the new devices.
*K	311054	See ECN	RYQ	Minor Change: Correct the revision indicated on the footer.