



High Performance Multibit $\Sigma\Delta$ DAC with SACD Playback

Preliminary Technical Data

AD1955

FEATURES

5V Power Supply Stereo Audio DAC System.
 Accepts 16/18/20/24-Bit Data
 Supports 24-Bits, 192kHz Sample Rate PCM Audio Data
 Supports SACD bit-stream and External Digital Filter Interface
 Accepts a Wide Range of PCM Sample Rates Including:
 32kHz, 44.1kHz, 48kHz, 88.2kHz, 96kHz, and 192kHz
 Multibit Sigma Delta Modulator with "Perfect Differential Linearity Restoration" for Reduced Idle Tones and Noise Floor
 Data Directed Scrambling DAC - Least Sensitive to Jitter
 Supports SACD playback with "Bit Expansion" filter
 Differential Current Output for Optimum Performance
 8.64 mA p-p Output Current with +3dB headroom in SACD mode
 120 dB SNR/DNR (not muted) at 48KHz Sample Rate (A-Weighted Stereo)
 123 dB SNR/DNR (Mono)
 -110 dB THD+N
 110 dB Stopband Attenuation with +/-0.0002dB Passband Ripple
 8 Times Oversampling Digital Filter
 On-chip Clickless Volume Control
 Supports SACD-Mute pattern detection
 Supports 64fs/128fs DSD SACD with phase modulation
 Internal Digital Filter pass-through for External Filter
 Master clock: 256fs, 384fs, 512fs, 768fs
 Hardware and Software Controllable Clickless Mute
 Serial (SPI) Control for: Serial Mode, Number of Bits, Sample Rate, Volume, Mute, De-emphasis, Mono Mode
 Digital De-emphasis for 32, 44.1, 48 KHz Sample Rates
 Flexible Serial Data Port with Right-Justified, Left-Justified, I²S-Compatible and DSP Serial Port
 28 Lead SSOP Plastic Package

FUNCTIONAL BLOCK DIAGRAM

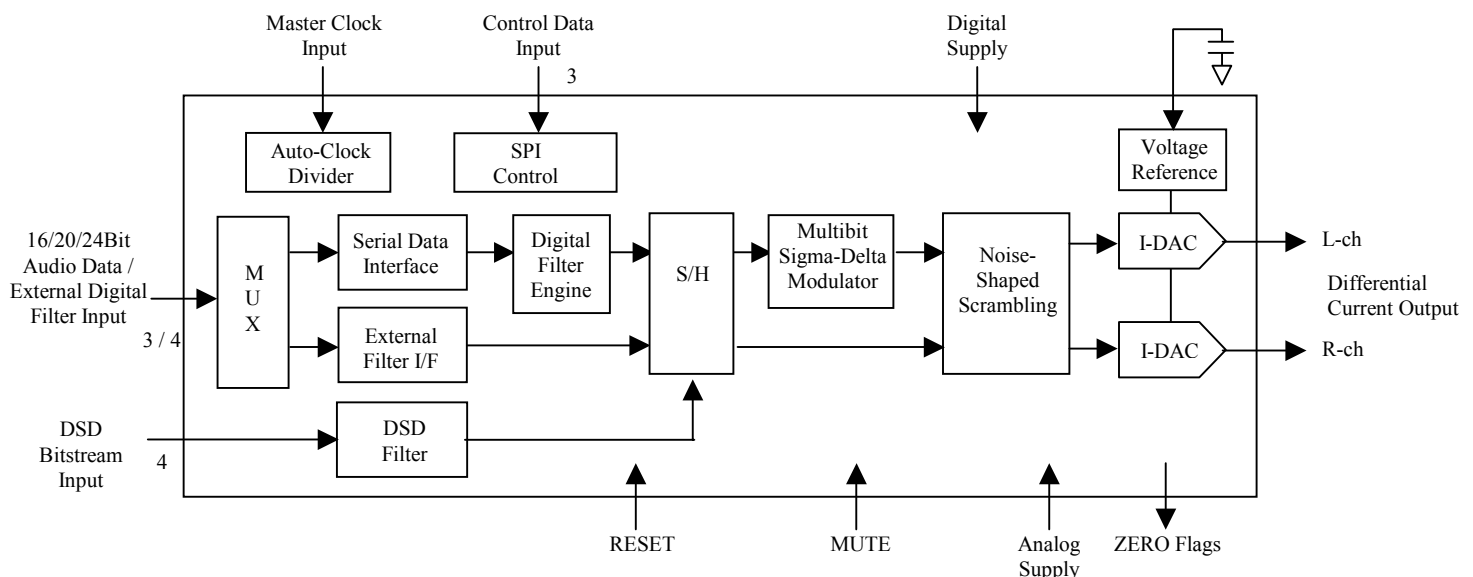

Rev. PrF 3/18/2002

Information furnished by Analog Devices is believed to be accurate and reliable. However, no responsibility is assumed by Analog Devices for its use; nor for any infringements of patents or other rights of third parties which may result from its use. No license is granted by implication or otherwise under any patent or patent rights of Analog Devices.

APPLICATIONS

High-End DVD-Audio, SACD, CD, Home Theatre Systems, Automotive Audio Systems, Sampling Musical Keyboards, Digital Mixing Consoles, Digital Audio Effects Processors

PRODUCT OVERVIEW

The AD1955 is a complete high performance single-chip stereo digital audio playback system. It is comprised of a multibit sigma-delta modulator, high performance digital interpolation filters, and continuous-time differential current output DAC section. Other features include an on-chip clickless stereo attenuator, mute capability, programmed through an SPI-compatible serial control port. The AD1955 is fully compatible with all known DVD audio formats including 192kHz as well as 96kHz sample frequencies and 24-bits. It also is backwards compatible by supporting 50/15 μ s digital de-emphasis intended for "redbook" Compact Discs, as well as de-emphasis at 32kHz and 48kHz sample rate.

The AD1955 has a very flexible serial data input port that allows for glueless interconnection to a variety of ADCs, DSPs, SACD decoder, external digital filter, AES/EBU receivers and sample rate converters. The AD1955 can be configured in Left-justified, I²S, Right-Justified, or DSP serial port compatible modes. It can support MSB first, two-complement format, 16, 18, 20 and 24 bits in all standard PCM modes. Also the AD1955 has an interface for SACD playback and an external digital filter interface for use with an external digital interpolation filter or HDCD decoder. The AD1955 uses a +5 V power supply. It is fabricated on a single monolithic integrated circuit and is housed in a 28-pin SSOP package for operation over the temperature range -40 $^{\circ}$ C to +105 $^{\circ}$ C.

PRELIMINARY TECHNICAL DATA

AD1955

TEST CONDITIONS UNLESS OTHERWISE NOTED

Analog Supply Voltages (AV _{DD})	+5.0V
Digital Supply Voltages (DV _{DD})	+5.0V
Reference Current (I _{ref})	.960 mA
Ambient Temperature	25°C
Input Clock	12.288 MHz
Input Signal	996.11 Hz
	0 dB Full Scale
Input Sample Rate	48 kHz
Measurement Bandwidth	20 Hz to 20KHz
Word Width	24 Bits
Load Capacitance	100 pF
Load Impedance	47 k ohms
Input Voltage HI	2.4 V
Input Voltage LO	.8 V

ANALOG PERFORMANCE (See Figures) I_{ref} = .960 mA

	Min	Typ	Max	Units
Resolution		24		Bits
Signal-to-noise Ratio (20 Hz to 20kHz)				
Differential Output (A-weighted, RMS) (Stereo)		120		dB
Differential Output (A-weighted, RMS) (Mono)		123		dB
Single-ended (Stereo)		119		dB
Dynamic Range (20 Hz to 20 kHz, -60 dB Input)				
Differential Output (A-weighted, RMS) (Stereo)		120		dB
Differential Output (A-weighted, RMS) (Mono)		123		dB
Single-ended (Stereo)		119		dB
Total Harmonic Distortion + Noise (Stereo) at 0 dBFS		-108		dB
Analog Outputs				
Differential Output range (Full Scale)		8.64		mA p-p
Output Capacitance at Each Output Pin			100	pF
Output bias current, Each Output		-3.24		mA
Out-of-Band Energy (0.5XFs to 100 kHz)			-90	dB
Reference Voltage		2.39		V
DC Accuracy				
Gain Error		+/-3		%
Interchannel Gain Mismatch		0.01		dB
Gain Drift		25		ppm/°C
Interchannel Crosstalk (EIAJ method)		-125		dB
Interchannel Phase Deviation		+/- 0.1		Degrees
Mute Attenuation		-100		dB
De-emphasis Gain Error			+/- 0.1	dB

NOTES:

Performance of right and left channels are identical (exclusive of the Interchannel Gain Mismatch and Interchannel Phase Deviation specifications).

Specifications subject to change without notice.

DIGITAL I/O (-40°C to 105°C)

	Min	Typ	Max	Units
Input Voltage HI (V _{IH})	2.0			V
Input Voltage LO (V _{IL})			0.8	V
Input Leakage (I _{IH} @V _{IH} =2.4 V)			10	uA
Input Leakage (I _{IL} @V _{IL} =0.8 V)			10	uA
High Level Output Voltage (V _{OH}) I _{OH} = 1 mA	2.4			V
Low Level Output Voltage (V _{OL}) I _{OL} = 1 mA			0.4	V
Input Capacitance			20	pF

Specifications subject to change without notice

PRELIMINARY TECHNICAL DATA

AD1955

TEMPERATURE RANGE

	Min	Typ	Max	Units
Specifications Guaranteed		25		°C
Functionality Guaranteed	-40		105	°C
Storage	-55		125	°C

Specifications subject to change without notice

POWER

	Min	Typ	Max	Units
Supplies				
Voltage, Digital	4.50	5	5.50	V
Voltage, Analog	4.50	5	5.50	V
Analog Current		17		mA
Analog Current - Reset		17		mA
Digital Current		22		mA
Digital Current - Reset		2		mA
Dissipation				
Operation - Both Supplies		195		mW
Operation - Analog Supply		85		mW
Operation - Digital Supply		110		mW
Power Supply Rejection Ratio				
1kHz 300 mV p-p Signal at Analog Supply Pins		-77		dB
20kHz 300 mV p-p Signal at Analog Supply Pins		-72		dB

Specifications subject to change without notice

DIGITAL FILTER CHARACTERISTICS

Sample Rate (kHz)	Passband (kHz)	Stopband (kHz)	Stopband Attenuation (dB)	Passband Ripple (dB)
44.1	DC-20	24.1-328.7	110	+/- 0.0002
48	DC-21.8	26.23-358.28	110	+/- 0.0002
96	DC-39.95	56.9-327.65	115	+/- 0.0005
192	DC-87.2	117-327.65	95	+0/-0.04 (DC-21.8 kHz) +0/-0.5 (DC-65.4 kHz) +0/-1.5 (DC-87.2 kHz)

Specifications subject to change without notice

GROUP DELAY

Chip Mode	Group Delay Calculation	Fs	Group Delay	Units
INT8x Mode	5553/(128 × FS)	48kHz	903.8	µs
INT4x Mode	5601/(64 × FS)	96kHz	911.6	µs
INT2x Mode	5659/(32 × FS)	192kHz	921	µs

Specifications subject to change without notice

DIGITAL TIMING (Guaranteed over -40°C to 85°C, AVDD = DVDD = +5.0 V +/- 10%)

		Min	Units
t _{DMP}	MCLK Period (FMCLK = 256*FLRCLK)	54	ns
t _{DML}	MCLK LO Pulse Width (all modes)	0.4 X t _{DMP}	ns
t _{DMH}	MCLK HI Pulse Width (all modes)	0.4 X t _{DMP}	ns
t _{DBH}	BCLK HI Pulse Width	20	ns
t _{DBL}	BCLK LO Pulse Width	20	ns
t _{DBP}	BCLK Period	60	ns
t _{DLS}	LRCLK Setup	20	ns
t _{DLH}	LRCLK Hold (DSP Serial Port mode only)	5	ns
t _{DDS}	SDATA Setup	5	ns
t _{DDH}	SDATA Hold	10	ns
t _{DMP}	CCLK Period	50	ns
t _{DML}	CCLK LO Pulse Width	15	ns
t _{DMH}	CCLK HI Pulse Width	15	ns
t _{CLS}	CLATCH Setup	10	ns
t _{CLH}	CLATCH Hold	10	ns
t _{CDS}	CDATA Setup	10	ns
t _{CDH}	CDATA Hold	10	ns
t _{RSTL}	RST LO Pulse Width	15	ns

Specifications subject to change without notice.

PRELIMINARY TECHNICAL DATA

AD1955

ABSOLUTE MAXIMUM RATINGS*

	Min	Max	Units
DV _{DD} to DGND	-0.3	6	V
AV _{DD} to AGND	-0.3	6	V
Digital Inputs	DGND - 0.3	DV _{DD} + 0.3	V
Analog Outputs	AGND - 0.3	AV _{DD} + 0.3	V
AGND to DGND	-0.3	0.3	V
Reference Voltage		(AV _{DD} + 0.3)/2	
Soldering		+300	°C
		10	sec

PACKAGE CHARACTERISTICS

	Min	Typ	Max	Units
O _{JA} (Thermal Resistance [Junction-to-Ambient])		109.0		°C/W
O _{JC} (Thermal Resistance [Junction-to-Case])		39.0		°C/W

* Stresses greater than those listed under Absolute Maximum Ratings may cause permanent damage to the device. This is a stress rating only; functional operation of the device at these or any other conditions above those indicated in the operational section of this specification is not implied. Exposure to absolute maximum rating conditions for extended periods may affect device reliability.

ORDERING GUIDE

Model	Temperature	Package Description	Package Option*
AD1955YRS	-40 °C to +105 °C	28-Lead SSOP	RS-28
AD1955YRSRL	-40 °C to +105 °C	28-Lead SSOP	RS-28 on 13" Reels

*RS = Shrink Small Outline

PIN CONFIGURATION



CAUTION

ESD (Electrostatic discharge) sensitive device. Electrostatic charges as high as 400 V readily accumulate on the human body and Test equipment and can discharge without detection. Although the AD1959 features proprietary ESD protection circuitry, permanent Damage may occur on devices subjected to high energy electrostatic discharges. Therefore, proper ESD precautions are recommended to avoid performance degradation or loss of functionality.

PIN FUNCTION DESCRIPTIONS

Pin	I/O	Pin Name	Description
1		DVDD	Digital Power Supply Connected to Digital 5V supply.
2	Input	EF_WCLK/LRCLK	Word Clock in External Filter mode. Left/Right Clock input for input data in PCM mode.
3	Input	EF_BCLK/BCLK	Bit Clock input in External Filter mode. Bit Clock input for input data in PCM mode.
4	Input	EF_LDATA/SDATA	8fs or 4fs L-ch Data input in External filter mode. Data should be MSB first two's complement format. In the PCM mode, serial input, MSB first, containing two channels(left and right) of 16 to 24bit two's complement 1fs data.
5	Input	EF_RDATA	8fs or 4fs R-ch Data input in External filter mode. Data should be MSB first two's complement format. Not used in PCM mode
6	I/O	DSD_SCLK	Shift clock input for DSD data. This clock should be 64x44.1kHz, 2.8224MHz or 128x44.1kHz, 5.6448MHz in normal mode or 128x44.1kHz, 5.6448MHz or 256x44.1kHz, 11.2896MHz in phase mode.
7	Input	DSD_LDATA	DSD Left channel data input
8	Input	DSD_RDATA	DSD Right channel data input
9	I/O	DSD_PHASE	DSD phase reference signal. This clock should be 64x44.1kHz, 2.8224MHz. If not used this pin should be connected Low.
10		AGND	Analog Ground
11	Output	IOUTR+	Right Channel Positive analog output.
12	Output	IOUTR-	Right Channel Negative analog output.
13	Output	FILTR	Voltage Reference Filter Capacitor Connection. Bypass and decouple the voltage reference with parallel 10uF and 0.1uF capacitors to AGND
14		IREF	Connection point for external bias resistor.
15		AVDD	Analog power supply Connected to Analog 5V supply
16	Output	FILTB	Filter Capacitor Connection with parallel 10uF and 0.1uF capacitors to AGND
17	Output	IOUTL-	Left Channel Negative analog output.
18	Output	IOUTL+	Left Channel Positive analog output.
19		AGND	Analog Ground
20	Output	ZEROR	Right Channel Zero Flag Output. This pin goes high when the right channel has no signal input or the DSD mute pattern is detected.
21	Output	ZEROL	Left Channel Zero Flag Output. This pin goes high when the left channel has no signal input or the DSD mute pattern is detected.
22	Input	MUTE	Mute. Assert HI to mute both stereo analog outputs. Deassert LO for normal operation.
23	Input	PD/RST	Power down/Reset. The AD1955 is placed in a reset state and the digital circuitry is powered down when this pin is held LO. The AD1955 is reset on the rising edge of this signal. The serial control port registers are reset to the default values. Connect HI for normal operation.
24	Input	CDATA	Serial control input, MSB first, containing 16 bits of unsigned data. Used for specifying control information and channel-specific attenuation.
25	Input	CLATCH	Latch Input for control data.
26	Input	CCLK	Control Clock input for control data. Control input data must be valid on the rising edge of CCLK. CCLK may be continuous or gated.
27	Input	MCLK	Master Clock Input. Connect to an external clock source.
28		DGND	Digital Ground

AD1955

OPERATING FEATURES

Serial Data Input Port

The AD1955's flexible serial data input port accepts standard PCM audio data and external digital filter output data in twos-complement, MSB-first format in PCM/External digital filter mode and a dedicated SACD serial port accepts DSD bit-stream data in SACD mode. If the PCM mode is selected by control register 0 bit 12 and 13, the left channel data field always precedes the right channel data field. The serial data format and word length in PCM mode are set by the mode select bits (bits 4 and 5 and bits 2 and 3, respectively) in the SPI control register.

In all data formats except for the right-justified mode, the serial port will accept an arbitrary number of bits up to a limit of 24 (extra bits will not cause an error, but they will be truncated internally). In Right-justified mode, control register 0, bits 2 and 3 are used to set the word length to 16, 18, 20, or 24 bits. The default on power up is 24-bit, I2S.

In the external digital filter mode, selected by control register 0 bit 12 and 13, bits 2 and 3 are used to set the word length to 16, 18, 20 or 24 bits and the format is set with bits 4 and 5. For a burst-mode clock, the format should be set to Left-justified. DSP mode is not used. The LRCLK is always falling-edge active. The default on power-up is 24-bit mode in PCM and external digital filter mode.

In SACD mode, selected by control register 0, bit 12 and 13, the SACD port will accept a DSD bit-stream.

When the SPI Control Port is not being used, the SPI pins (24, 25 and 26) should be tied to DGND or DVDD.

Serial Data Format in PCM mode

The supported formats are shown in Figure 1. For detailed timing, see Figure 2.

In Left-justified mode, LRCLK is HIGH for the left channel, and LOW for the right channel. Data should valid on the rising edge of BCLK. The MSB is left-justified to an LRCLK transition, with no MSB delay.

In I²S mode, LRCLK is LOW for the left channel, and HIGH for the right channel. Data should be valid on the rising edge of BCLK. The MSB is left-justified to an LRCLK transition but with a single BCLK period delay.

In DSP serial port mode, LRCLK must pulse HIGH for at least one bit clock period before the MSB of the left channel is valid, and LRCLK must pulse HI again for at least one bit clock period before the MSB of the right channel is valid. Data should be valid on the falling edge of BCLK. The DSP serial port mode can be used with any wordlength up to 24 bits.

In this mode, it is the responsibility of the DSP to ensure that the left data is transmitted with the first LRCLK pulse after RESET, and that synchronism is maintained from that point forward.

In Right-justified mode (16 bits shown), LRCLK is HIGH for the left channel, LOW for the right channel. Data is valid on the rising edge of BCLK.

In normal operation, there are 64 bit clocks per frame (or 32 per half-frame). When the SPI wordlength control bits (bits 2 and 3 in control register 0) are set to 24 bits (0:0), the serial port will begin to accept data starting at the 8th bit clock pulse after the LRCLK transition. When the word length control bits are set to 20-bit mode, data is accepted starting at the 12th bit clock position. In 18-bit mode, data is accepted starting at the 14th bit clock position. In 16-bit mode, data is accepted starting at the 16th bit clock position. These delays are independent of the number of bit clocks per frame, and therefore other data formats are possible using the delay values described above.

Note that the AD1955 is capable of a 32 X Fs BCLK frequency "packed mode" where the MSB is left-justified to an LRCLK transition, and the LSB is right-justified to the opposite LRCLK transition. LRCLK is HIGH for the left channel, and LOW for the right channel. Data is valid on the rising edge of BCLK. Packed mode can be used when the AD1955 is programmed in left or right-justified mode.

Serial Data Format in External Digital Filter mode

In the external digital filter mode, the AD1955 will accept up to 24 bits serial, twos complement, MSB first data from an external digital filter, an HDCD decoder or a general purpose DSP. If the external digital filter mode is selected by control register 0, bits 12 and 13, pins 2 to 5 are assigned as the word clock input (EF_WCLK, Pin 2), bit clock input (EF_BCLK, Pin 3), left channel data input (EF_LDATA, Pin 4) and right channel data input (EF_RDATA, Pin 5) respectively to accept 8fs (48 kHz), 4fs (96kHz) or 2fs (196 kHz) over-sampled data.

Left and Right channel data are valid on rising edge of EF_BCLK. After LSB data is clocked in the AD1955, the falling edge of EF_WCLK signal loads all of data and starts conversion. The mode can be set to Left or Right-justified. A burst mode BCLK is also acceptable in Left-justified mode.

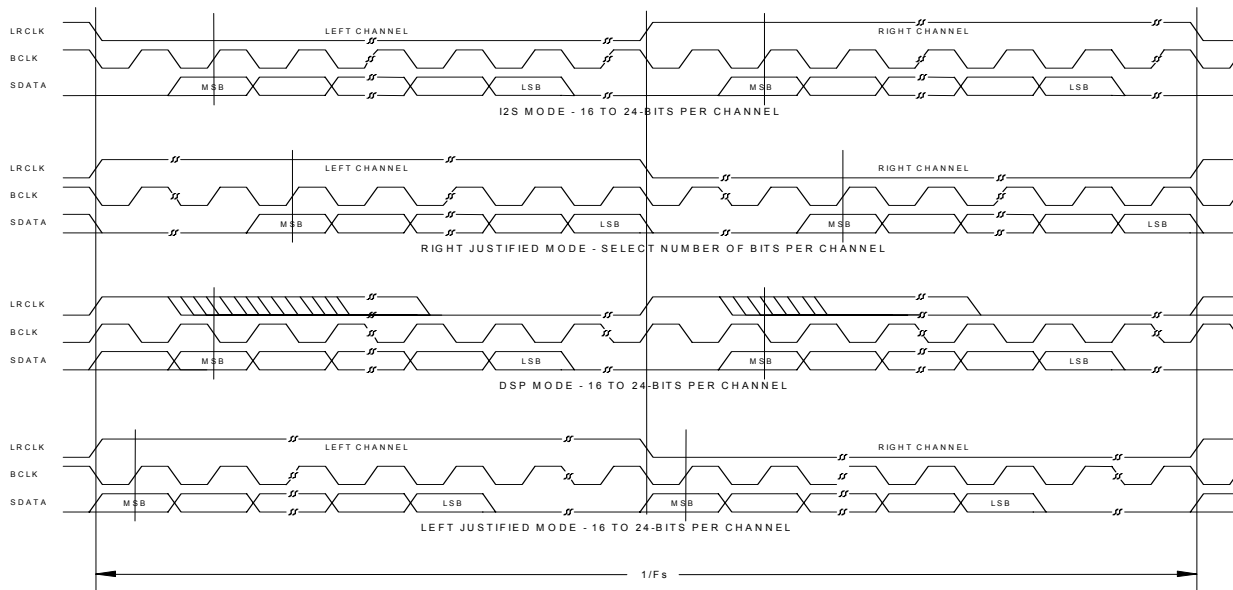

- NOTES: 1. DSP MODE DOESN'T IDENTIFY CHANNEL
- 2. LRCLK NORMALLY OPERATES AT F_s EXCEPT FOR DSP MODE WHICH IS $2 \times F_s$
- 3. BCLK FREQUENCY IS NORMALLY $64 \times LRCLK$ BUT MAY BE OPERATED IN BURST MODE

Figure 1. Supported Serial Data Formats

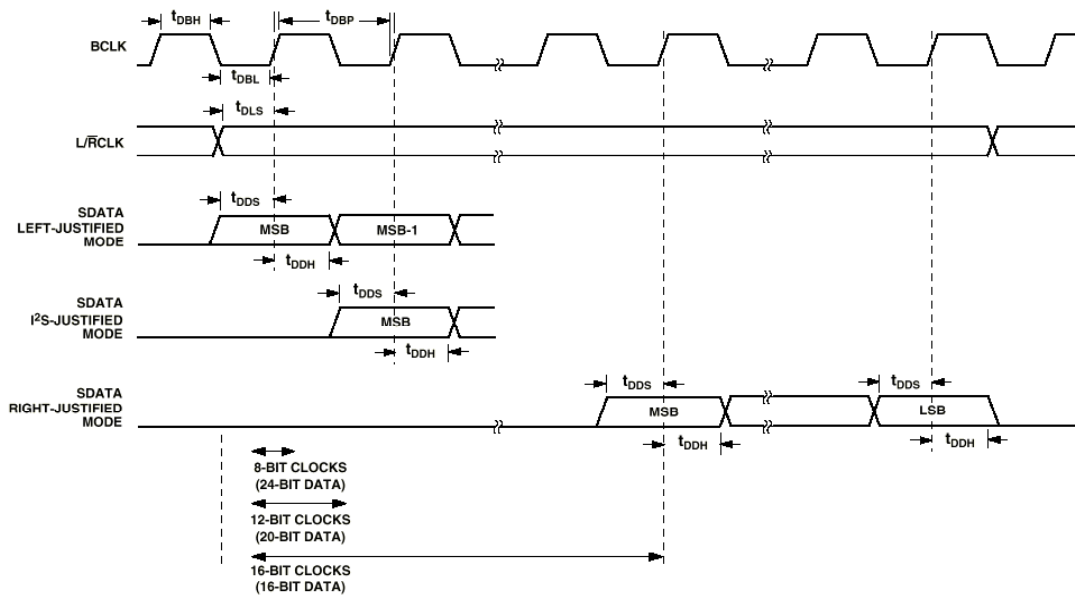

Figure 2. Serial Data Port Timing

AD1955

Serial Data Format in SACD mode

In the SACD mode, the AD1955 supports both normal mode or phase modulation mode, which are selected by Control register 1, bit 6. If normal mode is selected, DSD_SCLK, DSD_LDATA and DSD_RDATA are used to interface with DSD decoder chip. In this mode, the DSD data is clocked in the AD1955 using rising edge of DSD_SCLK with 64fs rate, 2.8224MHz. DSD_PHASE pin should be connected LOW.

If phase modulation mode is selected, DSD_PHASE pin is also used to interface with the DSD decoder. In this mode, a 64fs DSD_PHASE signal is used as a reference signal to receive the data from the decoder. The DSD data is clocked into the AD1955 with a 128fs DSD_SCLK.

The AD1955 can operate as a master or slave device. In master mode, the AD1955 will output DSD_SCLK and DSD_PHASE (if in the phase modulation mode) to a DSD decoder and will support normal mode and Phase modulation mode 0. In slave mode, the AD1955 will accept DSD_SCLK and DSD_PHASE (if in the phase modulation mode) from a DSD decoder and supports all of the normal and phase modulation modes.

When the SACD Port is not being used, the SACD pins (6, 7, 8 and 9) should be tied LOW.

Master Clock

The AD1955 must be set to the proper sample rate and master clock rate using Control Registers 0 and 1. The allowable master clock frequencies for each interpolation mode are as shown:

Interpolation Mode	Allowable master clock frequencies	Nominal Input Sample Rate
48kHz (INT8X) Mode	256*Fs, 384*Fs, 512*Fs,768*Fs	32 kHz, 44.1 kHz, 48 KHz
96kHz (INT4X) Mode	128*Fs, 192*Fs, 256*Fs, 384*Fs	88.2 kHz, 96 KHz
192kHz (INT2X) Mode	64*Fs, 96*Fs, 128*Fs, 192*Fs	176.4 kHz, 192 KHz

In the External Filter mode, the AD1955 accepts the following master clock frequencies depending on input sample rate:

Input Data rate	Allowable master clock frequencies	Nominal Input Sample Rate (to External Filter)
8fs	256*Fs, 384*fs, 512*Fs,768*Fs	32 kHz, 44.1 kHz, 48 KHz
4fs	128*Fs, 192*fs, 256*Fs, 384*Fs	88.2 kHz, 96 KHz
2fs	64*Fs, 96*fs, 128*Fs, 192*Fs	176.4 kHz, 192 KHz

In the SACD mode, the AD1955 accepts a 256fs, 512fs and 768fs Master Clock, where fs is nominally 44.1kHz.

Zero Detection

When the AD1955 detects that the audio input data is continuously zero during 1024 LRCLK periods in PCM mode or 8192 LRCLK periods in 8fs External Digital Filter mode, ZEROL (Pin 21) or ZEROR (Pin 20) is set to active.

When the AD1955 is in SACD Mode, it will detect an SACD mute pattern. If the input bit-stream shows a mute pattern for about 22ms, the AD1955 will set ZEROL(Pin 21) or ZEROR(Pin 20) to active. The outputs can be set to active high or low using Control Register 1, bit 8.

Reset/Power Down

The AD1955 will be reset when the RESET pin is set low. The part may be powered down using bit 15, Control Register 0.

Audio Outputs

The AD1955 audio outputs sink a current proportional to the input signal, superimposed on a steady state current. The current-to-voltage (I/V) converters used need to be able to supply this steady state current as well as the signal current or a resistor or current source can be used to a positive voltage to null this current to center the range of the I/V converters. Active I/V converters should be used, referenced to FILTR, and should hold the DAC outputs at this voltage level. Passive I/V conversion should not be used as the DAC performance will be seriously degraded.

Serial Control Port

The AD1955 has an SPI compatible control port to permit programming the internal control registers. The SPI control port is a three wire serial port. Its format is similar to the Motorola SPI format except that the input data word is 16-bits wide. The serial bit clock may be completely asynchronous to the sample rate of the DAC. The following figure shows the format of the SPI signal. Note that the CCLK may be continuous or a 16-clock burst.

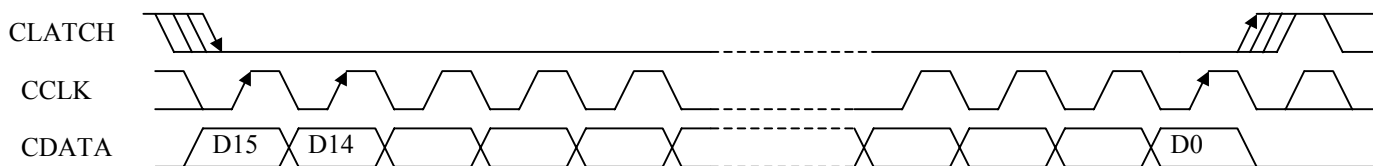

SPI REGISTER DEFINITIONS

Table 1: DAC Control Register 0

Bit 13: 12	Bit 11: 10	Bit 9:8	Bit 7:6	Bit 5: 4	Bit 3: 2	Bit 1: 0
Data format	Output Format	PCM Sample Rate	De-Emphasis Curve Select	PCM/ EF Serial Data Format	PCM/ EF Serial Data Width	SPI Register Address
00 : PCM 01 : Ext. DF 10 : SACD Slave 11 : SACD Master	00 : Stereo 01 : Not Allowed 10 : Mono Left 11 : Mono Right	00 : 48kHz 01 : 96kHz 10 : 192kHz 11 : Rsvd	00 : None 01 : 44.1kHz 10 : 32kHz 11 : 48kHz	00 : I2S 01 : Right-Just 10 : DSP 11 : LEFT-Just	00 : 24Bits 01 : 20Bits 10 : 18Bits 11 : 16Bits	00

Bit 15	Bit 14
Power Down	Mute
0 : Operation 1 : Powered Down	0 : Not Muted 1 : Muted

Note: 0 = Default Setting

Table 2: DAC Control Register 1

Bits 10:9	Bit 8	Bit 7	Bit 6	Bit 5:4	Bit 3	Bit 2	Bit 1: 0
MCLK Mode	Zero Flag Polarity	SACD Bit Rate	SACD Mode	SACD Phase Select	SACD Bit Inversion	SACD BCLK to MCLK Phase	SPI Register Address
00 : 256fs 01 : 512fs 10 : 768fs 11 : 384fs	0 : Active high 1 : Active low	0 : 8fs / 64fs 1 : 4fs / 128fs	0 : Normal 1 : Phase Mode	00 : Phase 0 01 : Phase 1 10 : Phase 2 11 : Phase 3	0 : Normal 1 : Inverted	0 : Rising edge 1 : Falling edge	01

Note: 0 = Default Setting

Table 3: DAC Volume Registers

Bit 15: 2	Bit 1: 0
Volume	SPI Register Address
14bit, Unsigned	10 = Left Volume
14bit, Unsigned	11 = Right Volume

Note: Default = full volume

PRELIMINARY TECHNICAL DATA

AD1955

OUTLINE DIMENSIONS Dimensions shown in inches and (mm) 28-Lead Shrink Small Outline Package (SSOP) (RS-28)

