

Tape and Reel Options for T-1^{3/4} (5 mm), T-1 (3 mm), LED Lamps

Technical Data

Option 01 Option 02

Features

- **Compatible with Radial Lead Automatic Insertion Equipment**
- **Meets Dimensional Specifications of IEC Publication 286 and ANSI/EIA Standard RS-468 for Tape and Reel**
- **Reel Packaging Simplifies Handling and Testing**
- **T-1 and T-1^{3/4} LED Lamps Available Packaged on Tape and Reel**
- **5 mm (0.197 inch) Formed Lead and 2.54 mm (0.100 inch) Straight Lead Spacing Available**

Description

T-1 and T-1^{3/4} LED lamps are available on tape and reel as specified by the IEC Publication 286 and ANSI/EIA Standard RS-468. The Option 01 lamp devices have formed leads with 5 mm (0.197 inch) spacing for automatic insertion into PC boards by radial lead insertion equipment. The Option 02 lamp devices have straight leads with 2.54 mm (0.100 inch) spacing, packaged on tape and reel for ease of handling. T-1 lamps are packaged 1800/reel. T-1^{3/4} lamps are packaged 1300/reel.

Ordering Information

To order LED lamps packaged on tape and reel, include the appropriate option code along with the device catalog part number. Example: to order the HLMP-3300 on tape and reel with formed leads (5 mm lead spacing) order as follows: HLMP-3300 Option 01. Minimum order quantities vary by part number. Orders must be placed in reel increments. Please contact your local Agilent sales office or franchised Agilent distributor for a complete list of lamps available on tape and reel.

LED lamps with 0.46 mm (0.018 inch) square leads with 5 mm (0.197 inch) lead spacing are recommended for use with automatic insertion equipment.

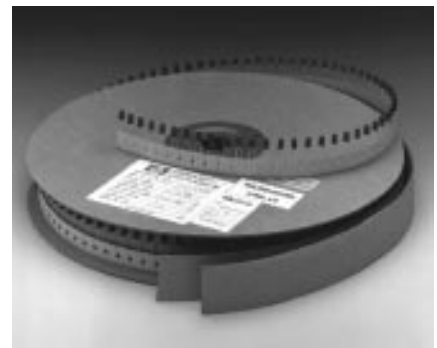

Caution: Agilent does not recommend T-1 package, option 02 LEDs for auto-insertion. The force exerted on the LED lead frame during the cut and clinch operation of auto-insertion may result in cracking of the lamp epoxy dome which results in catastrophic failure. It is suggested that insertion machine compatibility be confirmed.

Device Selection Guide

Option	Description
01	Tape and reel, 5 mm (0.197 inch) formed leads.
02	Tape and reel, 2.54 mm (0.100 inch) straight leads.

Package	Quantity/Reel	Order Increments
T-1	1800	1800
T-1 ^{3/4}	1300	1300

Tape and Reel LED Configurations (cont.)

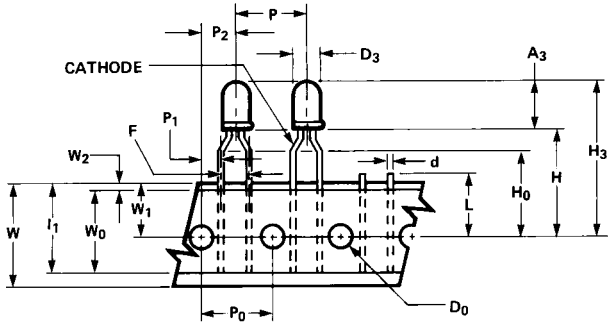

Figure 5. T-1^{3/4} High Profile Lamps, Option 01.

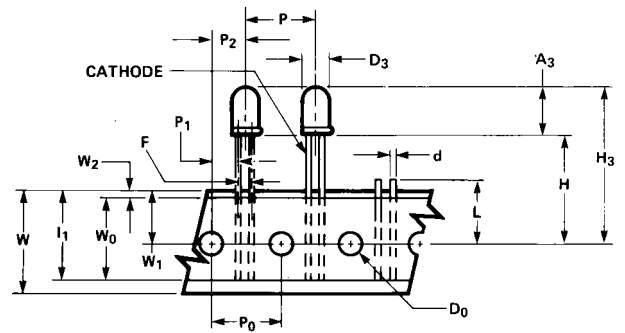

Figure 6. T-1^{3/4} High Profile Lamps, Option 02.

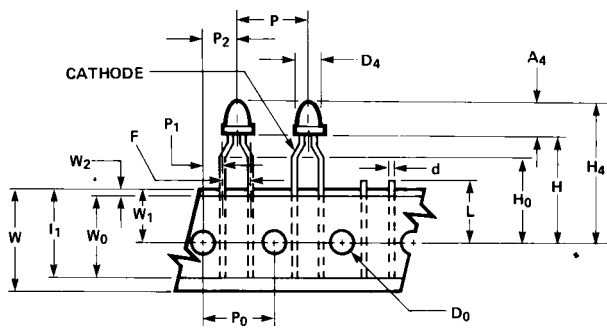

Figure 7. T-1^{3/4} Low Profile Lamps, Option 01.

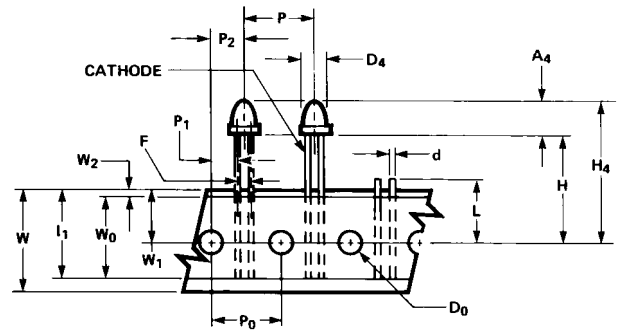









Figure 8. T-1^{3/4} Low Profile Lamps, Option 02.

Dimensional Specifications for Tape and Reel

Item	Option 01	02	Symbol	Specification	Notes
T1 High Profile Body Height			A1	$\frac{4.70 (0.185)}{4.19 (0.165)}$	
Body Diameter			D1	$\frac{3.18 (0.125)}{2.67 (0.105)}$	
Component Height			H1	25.7 (1.012) Max.	
T1 Low Profile Body Height			A2	$\frac{3.73 (0.147)}{3.23 (0.127)}$	
Body Diameter			D2	$\frac{3.05 (0.120)}{2.79 (0.110)}$	
Component Height			H2	24.7 (0.974) Max.	
T1^{3/4} High Profile Body Height			A3	$\frac{9.19 (0.362)}{8.43 (0.332)}$	
Body Diameter			D3	$\frac{5.08 (0.200)}{4.32 (0.170)}$	
Component Height			H3	30.2 (1.189) Max.	
T1^{3/4} Low Profile Body Height			A4	$\frac{6.35 (0.250)}{5.33 (0.210)}$	
Body Diameter			D4	$\frac{5.08 (0.200)}{4.32 (0.170)}$	
Component Height			H4	27.4 (1.079) Max.	
Lead Wire Thickness			d	0.45 (0.018)	Square Leads
Pitch of Component			P	$\frac{13.7 (0.539)}{11.7 (0.461)}$	
Feed Hole Pitch			P ₀	$\frac{12.9 (0.508)}{12.5 (0.492)}$	Cumulative error: 1.0 mm/20 pitches
Feed Hole Center to Lead Center			P1	$\frac{4.55 (0.179)}{3.15 (0.124)}$	Measure at crimp bottom 5.78/3.68 (0.227/0.1448) for straight leads
Hole Center to Component Center			P2	$\frac{7.35 (0.289)}{5.35 (0.211)}$	
Lead to Lead Distance			F	$\frac{5.40 (0.213)}{4.90 (0.193)}$	2.54 (0.100) nominal for straight leads
Component Alignment, Front-rear			Δh	0 ± 1.0 (0.039)	Figure 9
Tape Width			W	$\frac{18.5 (0.728)}{17.5 (0.689)}$	
Hold Down Tape Width			W ₀	$\frac{15.3 (0.602)}{12.0 (0.472)}$	
Hole Position			W1	$\frac{9.75 (0.384)}{8.50 (0.335)}$	

Dimensional Specifications for Tape and Reel (cont.)

Item	Option 01 02	Symbol	Specification	Notes
Hold Down Tape Position		W2	2.54 (0.100) Max.	
Height of Component from Hole Center		H	$\frac{21.0 (0.827)}{20.0 (0.787)}$	
Lead Clinch Height		H _O	$\frac{16.5 (0.650)}{15.5 (0.610)}$	
Feed Hole Diameter		D _O	$\frac{4.20 (0.165)}{3.80 (0.150)}$	
Total Tape Thickness		t	$\frac{0.90 (0.035)}{0.50 (0.020)}$	Paper thickness: 0.55 (0.022) 0.45 (0.018) Figure 9
Length of Snipped Lead		L	11.0 (0.433) Max.	
Lead Length Under Hold Down Tape		l1	14.5 (0.571) Min.	

Note:

1. Dimensions in millimetres (inches) maximum/minimum.

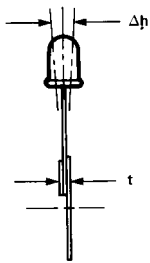

Figure 9. Front to Rear Alignment and Tape Thickness, Typical All Device Types.

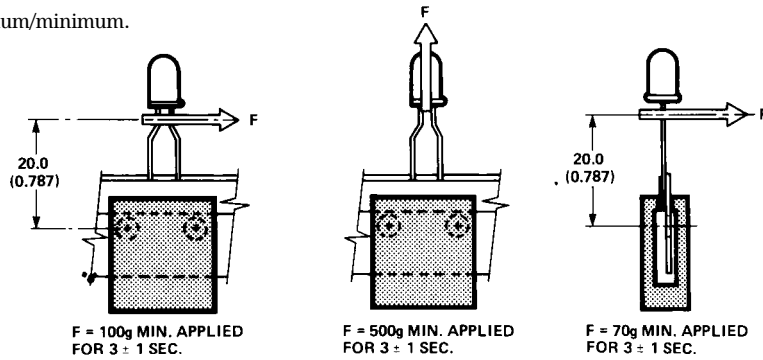

Figure 10. Device Retention Tests and Specifications.

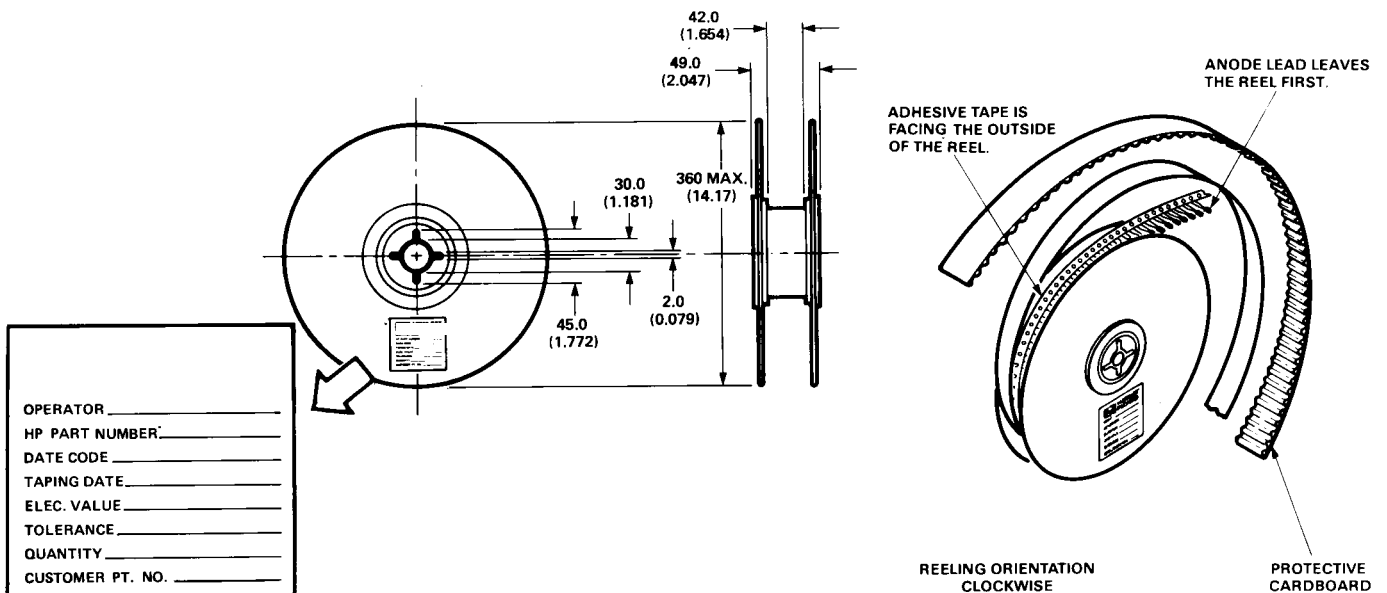
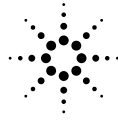

Figure 11. Reel Configuration and Labeling.



Agilent Technologies
Innovating the HP Way

www.semiconductor.agilent.com

Data subject to change.

Copyright © 1999 Agilent Technologies, Inc.

Obsoletes 5964-9375E (4/96)

5968-4164E (11/99)