

FEATURES

- InGaP HBT Technology
- High Efficiency:
 - 45 % @ $P_{OUT} = +28$ dBm
 - 20 % @ $P_{OUT} = +16$ dBm
 - 15 % @ $P_{OUT} = +7$ dBm
- Low Quiescent Current: 16 mA
- Low Leakage Current in Shutdown Mode: $<1 \mu A$
- $V_{REF} = +2.85$ V (+2.75 V min over temp)
- Optimized for a 50 Ω System
- Low Profile Miniature Surface Mount Package: 1.1 mm Max
- RoHS Compliant Package, 250 °C MSL-3
- HSDPA Capable

APPLICATIONS

- Dual Band WCDMA Wireless Handsets
- Dual Mode 3GPP Wireless Handsets

PRODUCT DESCRIPTION

The AWT6271 meets the increasing demands for higher output power in UMTS handsets. The PA module is optimized for $V_{REF} = +2.85$ V, a requirement for compatibility with the Qualcomm® 6250 chipset. The device is manufactured on an advanced InGaP HBT

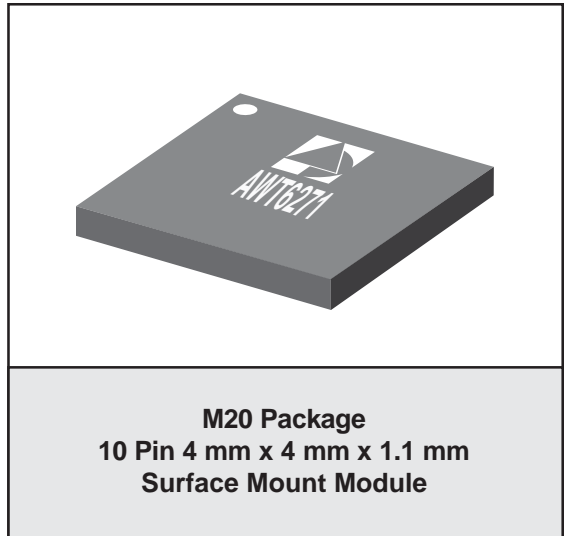

MMIC technology offering state-of-the-art reliability, temperature stability, and ruggedness. Selectable bias modes that optimize efficiency for different output power levels, and a shutdown mode with low leakage current, increase handset talk and standby time. The self-contained 4 mm x 4 mm x 1.1 mm surface mount package incorporates matching networks optimized for output power, efficiency, and linearity in a 50 Ω system.

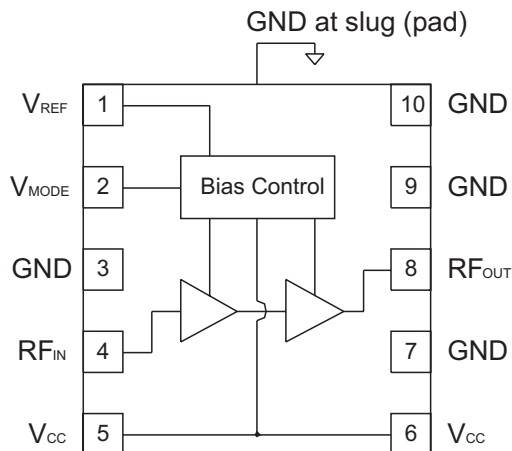

Figure 1: Block Diagram

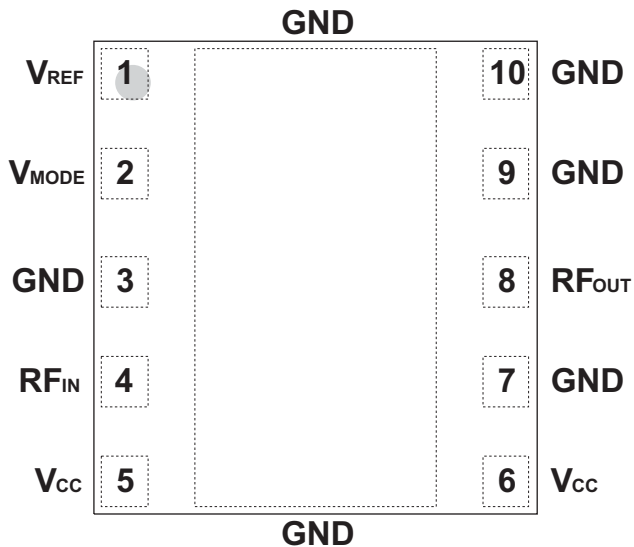

Figure 2: Pinout (X-ray Top View)

Table 1: Pin Description

PIN	NAME	DESCRIPTION
1	V_{REF}	Reference Voltage
2	V_{MODE}	Mode Control
3	GND	Ground
4	RF_{IN}	RF Input
5	V_{CC}	Supply Voltage
6	V_{CC}	Supply Voltage
7	GND	Ground
8	RF_{OUT}	RF Output
9	GND	Ground
10	GND	Ground

ELECTRICAL CHARACTERISTICS

Table 2: Absolute Minimum and Maximum Ratings

PARAMETER	MIN	MAX	UNIT
Supply Voltage (V_{CC})	0	+5	V
Mode Control Voltage (V_{MODE})	0	+3.5	V
Reference Voltage (V_{REF})	0	+3.5	V
RF Input Power (P_{IN})	-	+10	dBm
Case Operating Temperature	-30	+110	°C
Storage Temperature (T_{STG})	-40	+150	°C

Stresses in excess of the absolute ratings may cause permanent damage. Functional operation is not implied under these conditions. Exposure to absolute ratings for extended periods of time may adversely affect reliability.

Table 3: Operating Ranges

PARAMETER	MIN	TYP	MAX	UNIT	COMMENTS
Operating Frequency (f)	824	-	849	MHz	
Supply Voltage (V_{CC})	+3.2 -	+3.4 +1.5	+4.2 -	V	$P_{OUT} \leq +28$ dBm $P_{OUT} \leq 7$ dBm
Reference Voltage (V_{REF})	+2.75 0	+2.85 -	+2.95 +0.5	V	PA "on" PA "shut down"
Mode Control Voltage (V_{MODE})	+2.5 0	+2.8 -	+3.1 +0.5	V	Low Bias Mode High Bias Mode
RF Output Power (P_{OUT})	+27.5 ⁽¹⁾	+28	-	dBm	
Case Temperature (T_C)	-20	-	+110 ⁽²⁾	°C	

The device may be operated safely over these conditions; however, parametric performance is guaranteed only over the conditions defined in the electrical specifications.

Notes:

(1) For operation at $V_{CC} = +3.2$ V, P_{OUT} is derated by 0.5 dB.

(2) For operation at 110 °C (T_C), P_{OUT} is derated by 1.0 dB.

Table 4: Electrical Specifications
 (T_C = +25 °C, V_{CC} = +3.4 V, V_{REF} = +2.85 V, 50 Ω system)

PARAMETER	MIN	TYP	MAX	UNIT	COMMENTS
Gain	25 14 13	27 16 15	29 18 17	dB	P _{OUT} = +28 dBm, V _{MODE} = 0 V P _{OUT} = +16 dBm, V _{MODE} = +2.85 V P _{OUT} = +7 dBm, V _{CC} = 1.5 V, V _{MODE} = +2.85 V
ACLR1 at 5 MHz offset ⁽¹⁾	- - -	-41 -46 -44	-38 -38 -38	dBc	P _{OUT} = +28 dBm, V _{MODE} = 0 V P _{OUT} = +16 dBm, V _{MODE} = +2.85 V P _{OUT} = +7 dBm, V _{CC} = 1.5 V, V _{MODE} = +2.85 V
ACLR2 at 10 MHz offset	- - -	-57 -55 -58	-48 -48 -48	dBc	P _{OUT} = +28 dBm, V _{MODE} = 0 V P _{OUT} = +16 dBm, V _{MODE} = +2.85 V P _{OUT} = +7 dBm, V _{CC} = 1.5 V, V _{MODE} = +2.85 V
Power-Added Efficiency ⁽¹⁾	41 17 12	45 20 14.5	- - -	%	P _{OUT} = +28 dBm, V _{MODE} = 0 V P _{OUT} = +16 dBm, V _{MODE} = +2.85 V P _{OUT} = +7 dBm, V _{CC} = 1.5 V, V _{MODE} = +2.85 V
Quiescent Current (I _q)	-	16	22	mA	V _{MODE} = +2.85 V, V _{CC} = 1.5 V
Reference Current	-	3.8	5	mA	through V _{REF} pin
Mode Control Current	-	0.6	1	mA	through V _{MODE} pin, V _{MODE} = +2.85 V
Leakage Current	-	<1	5	μA	V _{CC} = +4.2 V, V _{REF} = 0 V, V _{MODE} = 0 V
Noise in Receive Band	- -	-135 -142	-133 -139	dBm/Hz	869 MHz to 894 MHz P _{OUT} = +27.5 dBm, V _{MODE} = 0 V 869 MHz to 894 MHz P _{OUT} = +16 dBm, V _{MODE} = +2.85 V
Harmonics 2fo 3fo, 4fo	- -	-42 -50	-30 -30	dBc	
Input Impedance	-	-	2:1	VSWR	
Spurious Output Level (all spurious outputs)	-	-	-70	dBc	P _{OUT} ≤ +28 dBm In-band load VSWR < 5:1 Out-of-band load VSWR < 10:1 Applies over all operating conditions
Load mismatch stress with no permanent degradation or failure	10:1	-	-	VSWR	Applies over full operating range

Notes:

(1) ACLR and Efficiency measured at 836.5 MHz.

APPLICATION INFORMATION

To ensure proper performance, refer to all related Application Notes on the ANADIGICS web site: <http://www.anadigics.com>

Shutdown Mode

The power amplifier may be placed in a shutdown mode by applying logic low levels (see Operating Ranges table) to both the V_{REF} and V_{MODE} voltages.

Bias Modes

The power amplifier may be placed in either a Low Bias mode or a High Bias mode by applying the

appropriate logic level (see Operating Ranges table) to the V_{MODE} voltage. The Bias Control table lists the recommended modes of operation for various applications.

Three operating modes are recommended to optimize current consumption. High Bias/High V_{CC} operating mode is for P_{OUT} levels ≥ 16 dBm. At ~ 16 dBm - 7 dBm, the PA should be "Mode Switched" to Low Bias Mode. For P_{OUT} levels $\leq \sim 7$ dBm, the V_{CC} can be switched to 1.5 V (Low Bias Mode is also used for this P_{OUT} range).

Table 5: Bias Control

APPLICATION	P_{OUT} LEVELS	BIAS MODE	V_{REF}	V_{MODE}	V_{CC}
CDMA - low power	$\leq +7$ dBm	Low	+2.85 V	+2.85 V	$\geq +1.5$
CDMA - med power	$7 \leq P_{OUT} \leq +16$ dBm	Low	+2.85 V	+2.85 V	+3.4
CDMA - high power	$> +16$ dBm	High	+2.85 V	0 V	+3.4
Shutdown	-	Shutdown	0 V	0 V	-

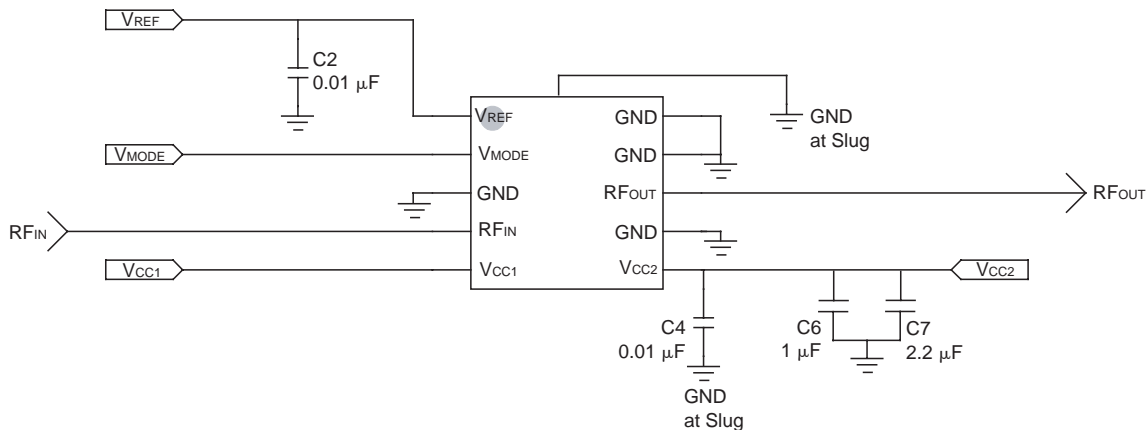
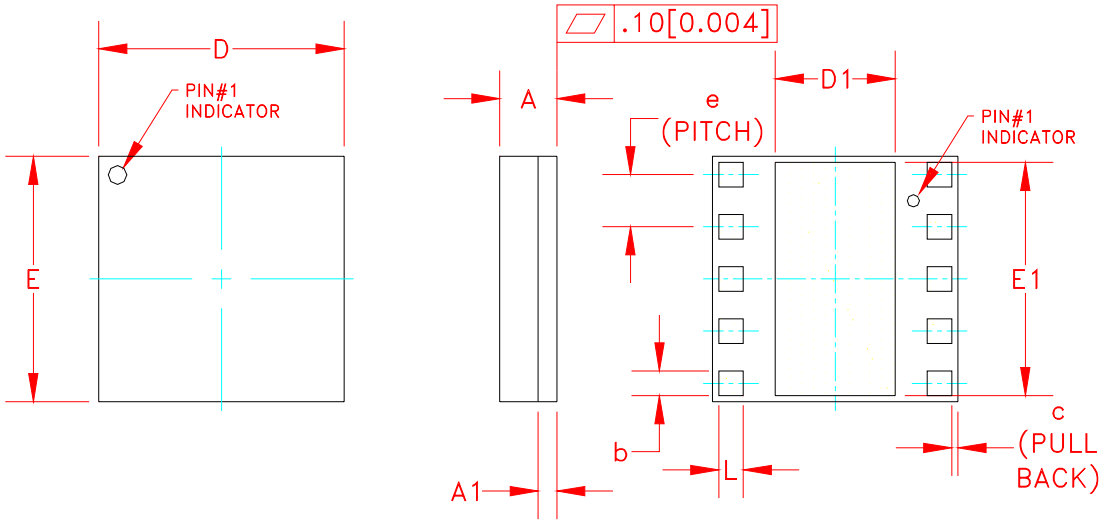

Figure 3: Application Schematic



SYMBOL	MILLIMETERS			INCHES			NOTE
	MIN.	NOM.	MAX.	MIN.	NOM.	MAX.	
A	0.90	1.00	1.10	0.035	0.039	0.043	-
A1	-	0.35	-	-	0.014	-	-
b	0.35	-	0.60	0.013	-	0.024	3
c	-	0.10	-	-	0.004	-	-
D	3.88	4.00	4.12	0.152	0.157	0.162	-
D1	1.90	-	2.20	0.075	-	0.086	-
E	3.88	4.00	4.12	0.152	0.157	0.162	-
E1	3.75	-	3.85	0.148	-	0.152	-
e	-	0.85	-	-	0.033	-	3
L	0.35	-	0.60	0.013	-	0.024	3

NOTES:

1. CONTROLLING DIMENSIONS: MILLIMETERS
2. UNLESS SPECIFIED TOLERANCE=±0.076[0.003].
3. PADS (INCLUDING CENTER) SHOWN UNIFORM SIZE FOR REFERENCE ONLY. ACTUAL PAD SIZE AND LOCATION WILL VARY WITHIN MIN. AND MAX. DIMENSIONS ACCORDING TO SPECIFIC LAMINATE DESIGN.

Figure 4: M20 Package Outline - 10 Pin 4 mm x 4 mm x 1.1 mm Surface Mount Module

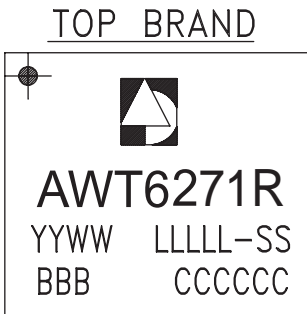

NOTES:

1. ANADIGICS LOGO SIZE: X=0.040±0.010 Y=0.048±0.010
2. PART # AWT6271R
3. YEAR AND WORK WEEK: YYWW: YY = YEAR, WW = WORK WEEK
4. LOT - WAFER I.D.: LLLLL - SS = WAFER/LOT I.D.
5. PIN 1 INDICATOR: MOLD NOTCH -or- INK DOT
6. BOM # BBB
7. COUNTRY CODE: CCCCC
8. TYPE : ELITE
SIZE : AS LARGE AS POSSIBLE
LASER MARKED

Figure 5: Branding Specification - M20 Package

COMPONENT PACKAGING

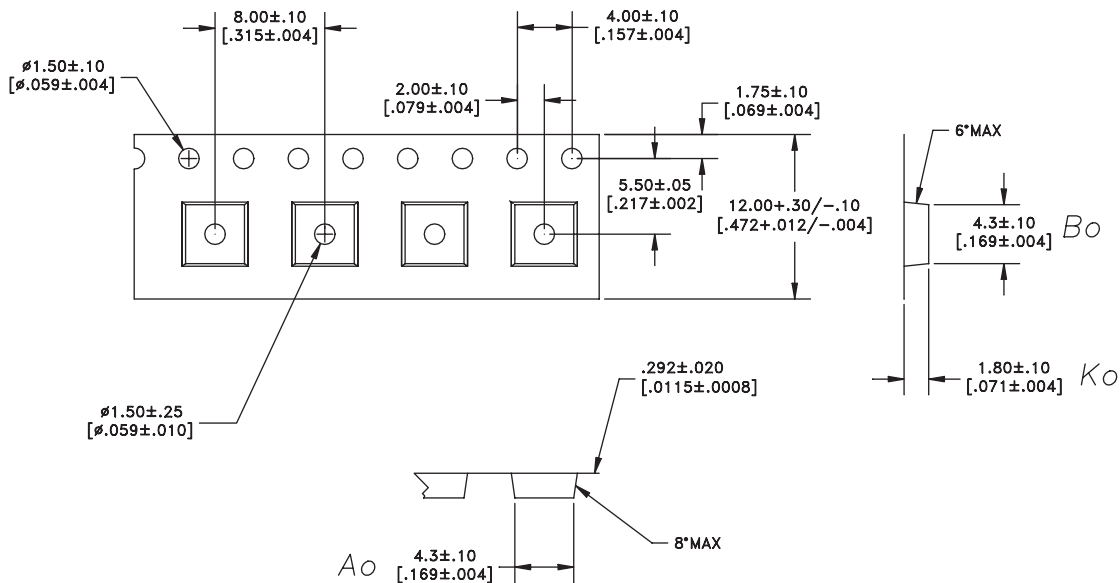

DIMENSIONS ARE IN MILLIMETERS [INCHES]
STANDARD TOLERANCES

Figure 6: Tape & Reel Packaging

Table 6: Tape & Reel Dimensions

PACKAGE TYPE	TAPE WIDTH	POCKET PITCH	REEL CAPACITY	MAX REEL DIA
4 mm x 4 mm x 1.6 mm	12 mm	8 mm	2500	13"

ORDERING INFORMATION

ORDER NUMBER	TEMPERATURE RANGE	PACKAGE DESCRIPTION	COMPONENT PACKAGING
AWT6271RM20P8	-20 °C to +100 °C	RoHS Compliant 10 Pin 4 mm x 4 mm x 1.1 mm Surface Mount Module	Tape and Reel, 2500 pieces per Reel



ANADIGICS, Inc.

141 Mount Bethel Road
Warren, New Jersey 07059, U.S.A.
Tel: +1 (908) 668-5000
Fax: +1 (908) 668-5132

URL: <http://www.anadigics.com>
E-mail: Mktg@anadigics.com

IMPORTANT NOTICE

ANADIGICS, Inc. reserves the right to make changes to its products or to discontinue any product at any time without notice. The product specifications contained in Advanced Product Information sheets and Preliminary Data Sheets are subject to change prior to a product's formal introduction. Information in Data Sheets have been carefully checked and are assumed to be reliable; however, ANADIGICS assumes no responsibilities for inaccuracies. ANADIGICS strongly urges customers to verify that the information they are using is current before placing orders.

WARNING

ANADIGICS products are not intended for use in life support appliances, devices or systems. Use of an ANADIGICS product in any such application without written consent is prohibited.