

MMIC Broadband Amplifier, 2 - 18GHz

The **P35-4150-000-200** is a high performance monolithic broadband amplifier designed for use in a wide range of applications including telecommunications, instrumentation and electronic warfare. The amplifier gives typically 5.0dB gain over the frequency range 2GHz to 18GHz. On chip input and output blocking capacitors simplify assembly and allow the amplifiers to be cascaded easily.

The die is fabricated using Bookham Technology's F20 Gallium Arsenide MESFET MMIC process. It is fully protected using Silicon Nitride passivation for excellent performance and reliability.

Features

- Broadband, cascadable gain block
- AGC control with gate bias
- Output power, 15dBm, typical
- Gain flatness ± 0.5 dB, typical
- On chip DC blocking capacitors at input and output
- Space - qualified version available

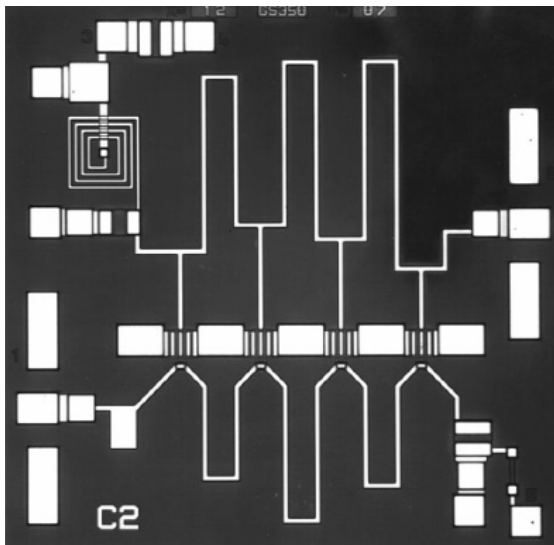

Electrical Performance

Ambient temperature = 22 ±3 deg C, Zo = 50 ohms, Vd = 5V, Id = 50% Idss

Parameter	Conditions	Min	Typ	Max	Units
Small signal gain ¹	2GHz - 18GHz	5.0	6.0	-	dB
Gain Flatness	2GHz - 18GHz		±0.5	±1.0	dB
Input Return Loss ³	2GHz - 18GHz	9	10	-	dB
Output Return Loss ³	2GHz - 18GHz	9	10	-	dB
Noise figure	2GHz - 18GHz		7.5	8.5	dB
Output Power at 1dB compression	2GHz	17.0	18.0		dBm
	18GHz	14.0	15.0		dBm
Reverse Isolation	2GHz	-	28.0	-	dB
	18GHz		14.0		dB
Drain Voltage Vd		+4.5	+5.0	+5.5	Volts
Gate Voltage Vg ²	For Id = 60mA	0	-0.6	-5	Volts

Notes

1. At 50% Idss, which will be in the range 40-80mA.
2. Gain control can be achieved with variation of Vg typically 3dB/volt.
3. Two wires (25 μm diameter), maximum length 0.33mm at RF in and RF out.

Typical Performance at 22° C

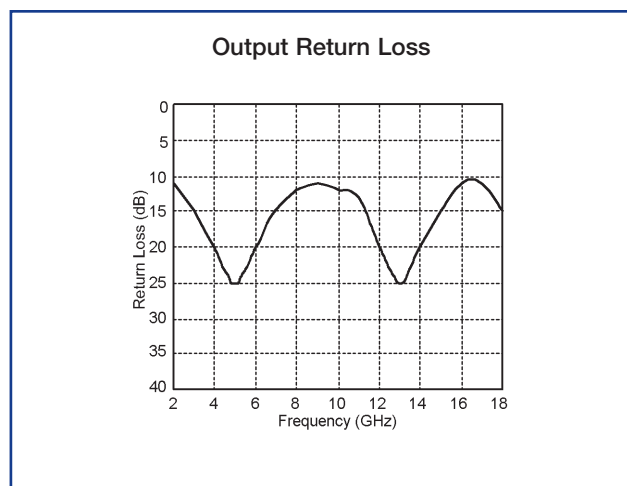
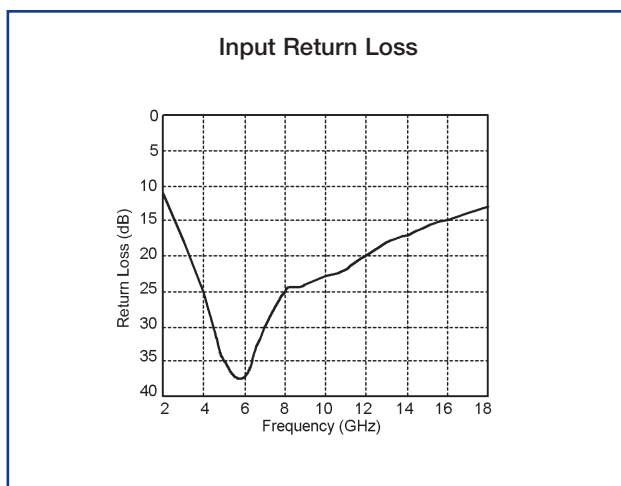
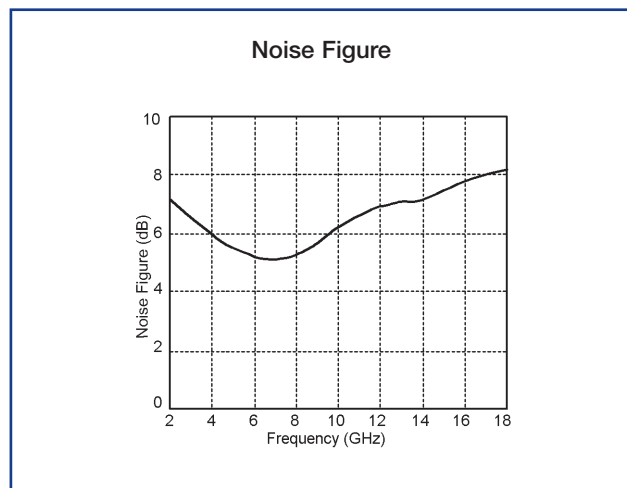
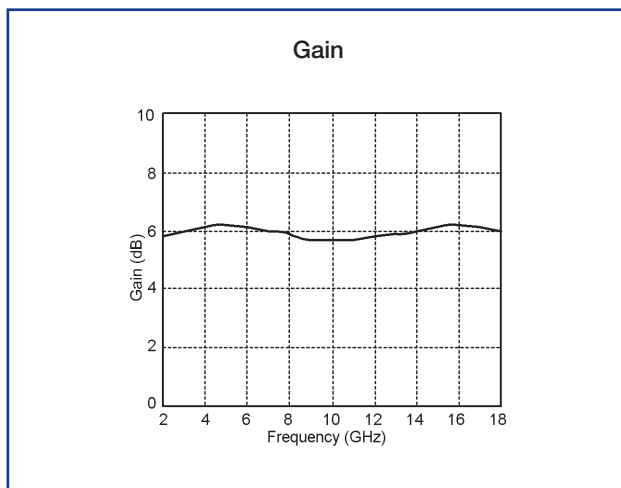

Absolute Maximum Ratings

Max supply voltage	+6.0V
Max Vgs	-5.0V
Operating temperature	-55 °C to 125 °C
Storage temperature	-65 °C to +150 °C

Operation

To operate the P35-4150-000-200, a drain supply of 5V is connected to pad 3. The amplifier circuit is controlled by the voltage applied at pad 5 and should be set to give a drain current of 50% I_{dss} which will be in the range of 40-80mA, typically 60mA. The voltage required for this is typically -0.6V. Gain control achieved with the variation of V_g is typically 3dB/volt at 50% I_{dss} . Decoupling capacitors of 470pF are required at the gate and drain bias inputs. Additional drain decoupling with a 4.7 μ F capacitor is recommended. The RF connections should be made with two wires (25 μ m diam), Maximum length 0.3mm at RF in and RF out. See application note P35-41AN2 for more details. It is recommended that the die is mounted with silver loaded epoxy and bonding to all pads is with 25 μ m diameter gold wire using thermal compression bonding. Gain variation with temperature is typically 0.015dB/ $^{\circ}$ C

Die Outline

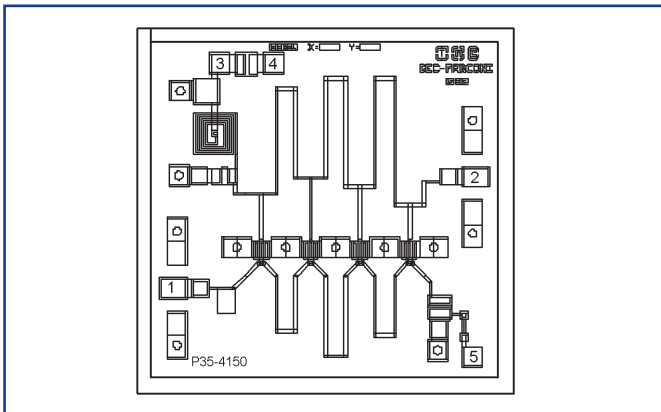

Die size: 2.21 x 2.135mm
 Bond pad size: 120 μ m square
 Die thickness: 200 μ m

Die bias connections

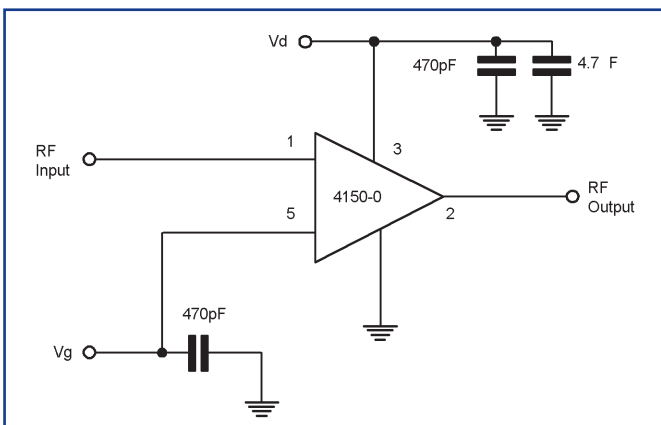

Pad Details

Pad	Function
1	RF IN
2	RF OUT
3	Drain Voltage V_d
4	N/C
5	Gate Voltage V_g

Ordering Information

P35-4150-000-200



Thinking RF solutions

MMICS

Bookham Technology plc
 Caswell
 Towcester
 Northamptonshire
 NN12 8EQ
 UK

• Tel: +44 (0) 1327 356 789

• Fax: +44 (0) 1327 356 698

rfsales@bookham.com

Important Notice

Bookham Technology has a policy of continuous improvement. As a result certain parameters detailed on this flyer may be subject to change without notice. If you are interested in a particular product please request the product specification sheet, available from any RF sales representative.



22735