

PIR Sensor Type G 8110 1127



- Passive infrared detector (PIR)
- Detects movement by e.g. a person
- Indoor applications
- Operating distance: Max. 6 m
- Operating angle: 90°
- Walk test: LED indication
- Channel coding by GAP 1605
- Supplied by Dupline[®]

Product Description

Non-powered Dupline[®] passive infrared detector with built-in transmitter. For detection of movement by e.g. a person. Used for light control etc.

Type Selection

Supply	Ordering no.
By Dupline [®]	Fuga: G 8110 1127

Supply Specifications

Power supply	Supplied by Dupline [®]
Consumption	
Activated	< 2.6 mA
Activated (LED ON)	< 3.5 mA

Input/Output Specifications

Inputs	PIR on I/O 1
Lens	Dual detecting zones
Segments	9
Levels	3
Angle	90°
Operating distance	≤ 6 m
Wave length	(see radiation diagram) 7 to 14 μm
Input detection speed	0.5 to 5 pulses/s
Outputs	Red LED on I/O 2

Wiring Diagram

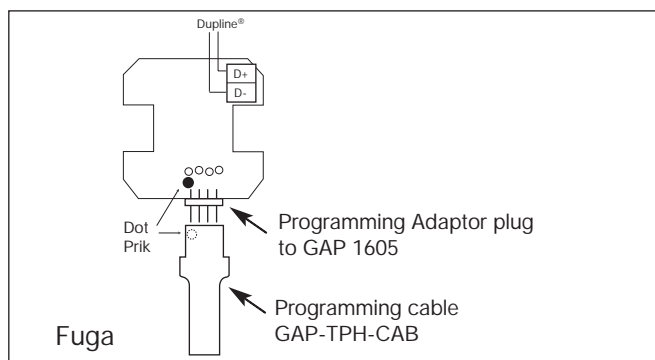

Ordering Key

G 8110 1127

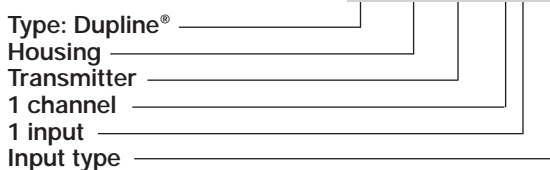

General Specifications

Channel coding	By GAP 1605 and special cable: GAP-TPH-CAB
No. of channels	1
Enclosure	LKNES FUGA Mechanics
Environment	Degree of protection: IP 20 Pollution degree: 3 (IEC 60664) Operating temperature: 0 - 50 °C (32 - 122°F) Storage temperature: -20 - 70°C (-4 - 158°F)
Humidity (non condensing)	20 - 80%
Weight	50 g
Dimensions	Fuga: 50 x 50 x 30 mm (including frame)
Connection	Screw terminals Max. wire in terminals: 4 x 0.75 mm ² Terminal D+: Signal Terminal D-: GND
Power-on delay	Typ. 10 s

Dimensions

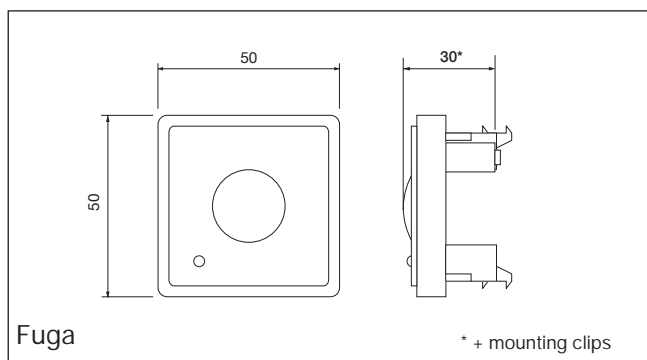

Mode of Operation

G 8110 1127 is a 1-channel monostable transmitter with a PIR detector, which operates by means of a dual-element detector.

The transmitter is activated if the temperature suddenly changes (most often it will be heat radiation from a person) in relation to the background radiation. Consequently, the transmitter can be used for ON/OFF switching of lighting, air conditioning etc. If a person moves within a detection zone, G 8110 1127 is activated.

The PIR detector is designed for mounting at a **standard** switch height.

Slow movements between zones resulting in a detection speed of less than 0.5 pulses/sec will not be detected. Nor will rapid movements resulting in a detection speed of more than 5 pulses/sec be detected. As G 8110 1127 is a passive device, several detectors can be placed in the same room without interfering with each other.

Walk test: The LED responds to any channel coded on I/O 2. If the LED is coded to the same channel as the PIR input on I/O 1, the transmission follows the LED. The LED turns ON when the PIR is activated.

The module should not be installed as follows:

- a) Outdoors.
- b) In places exposed either to sunlight or to motor vehicle headlights pointing directly at the sensor.

- c) In places exposed to direct air flow from a heater or air conditioner.
- d) In places where rapid temperature changes occur.
- e) In places exposed to severe vibration.
- f) Close to glass or other objects which might reflect the infrared radiation.
- g) For burglar detection.

Radiation Diagrams

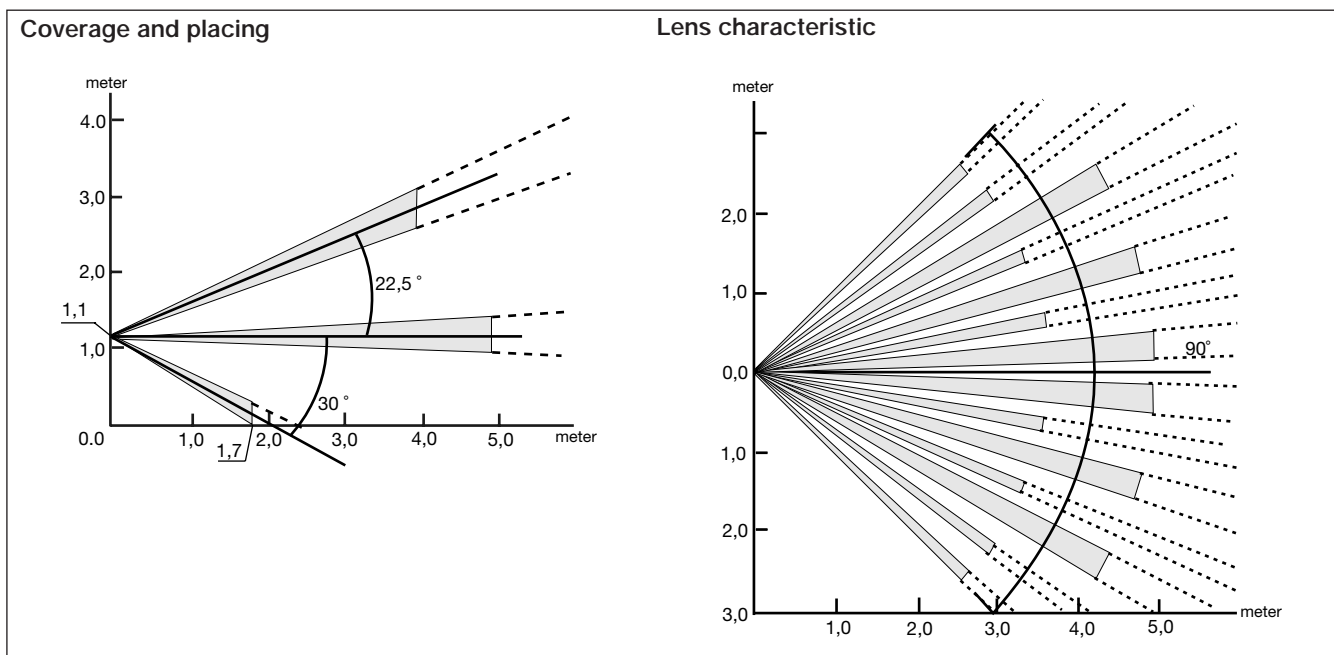

Accessories

Programming cable to GAP 1605

GAP-TPH-CAB