



MODEL NO: 12-215SURC/S530-A2/TR8

Device Number : DSE-125-012 REV. 1.1

Chip LEDs with Right Angle Lens

ECN : _____ Page: 1/8

■ **Features :**

- Package in 8mm tape on 7" diameter reel .
- Compatible with automatic placement equipment.
- Compatible with infrared and vapor phase reflow solder process.
- Mono-color type.

■ **Descriptions :**

- The 12-215 SMD Taping is much smaller than lead frame type components, thus enable smaller board size, higher packing density, reduced storage space and finally smaller equipment to be obtained.
- Besides, light Weight makes them ideal for miniature applications, etc.

■ **Applications :**

- Automotive: backlighting in dashboards and switches.
- Telecommunication: indicator and backlighting in telephone and fax.
- Flat backlight for LCD, switches and symbols.
- General use.

■ **Package Dimensions :**

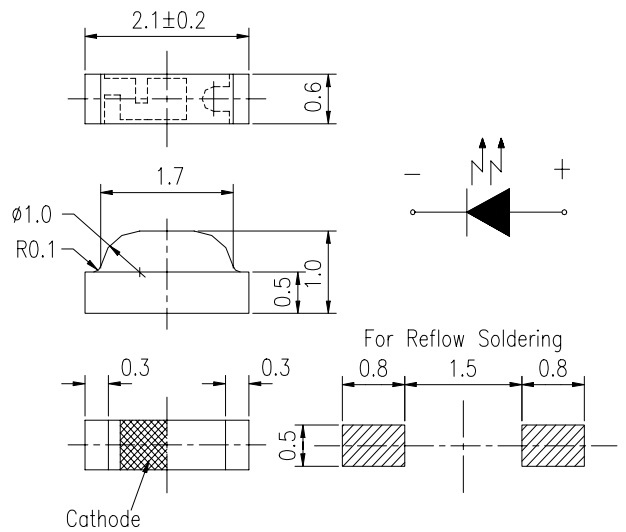

■ **Notes :**

Tolerances Unless Dimension ±
0.1mm
Angle ±0.5°

PART NO	Chip		Lens Color
	Material	Emitted Color	
12-215 SURC/S530-A2/TR8	AlGaInP	Hyper Red	Water Clear

Office: NO. 25, Lane 76, Sec.3, Chung Yang Rd., Tucheng 236, Taipei, Taiwan, R.O.C.

TEL: 886-2-2267-2000, 2267-9936

FAX: 886-2-2267-6244, 2267-6189, 2267-6306

<http://www.everlight.com>



MODEL NO: 12-215SURC/S530-A2/TR8

Device Number : DSE-125-012 REV. 1.1

Chip LEDs with Right Angle Lens

ECN : _____ Page: 2/8

■ Package Dimensions :

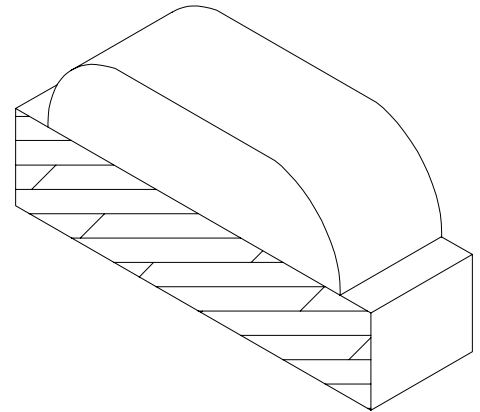
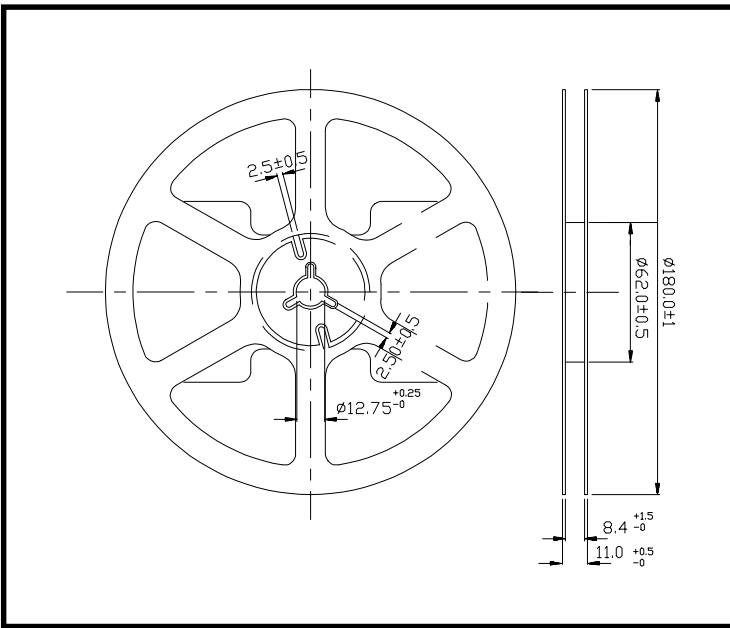

■ Loaded quantity per reel 3000 PCS/reel :

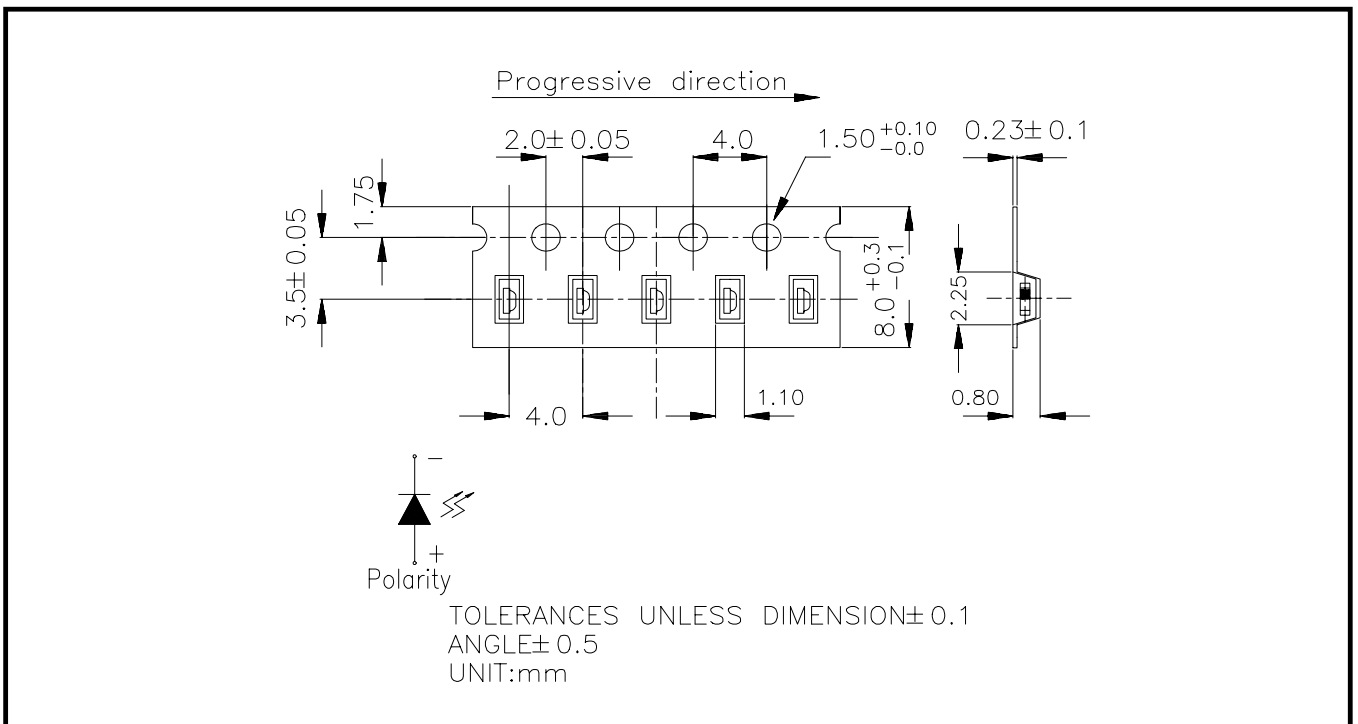



MODEL NO: 12-215SURC/S530-A2/TR8

Device Number : DSE-125-012 REV. 1.1

Chip LEDs with Right Angle Lens

ECN : _____ Page: 3/8

■ **Absolute Maximum Ratings at Ta = 25°C**

Parameter	Symbol	Rating	Unit
Reverse Voltage	V _R	5	V
Forward Current	I _F	25	mA
Operating Temperature	T _{opr}	-40 ~ +85	°C
Storage Temperature	T _{stg}	-40 ~ +90	°C
Soldering Temperature	T _{sol}	260 (for 5 second)	°C
Power Dissipation	P _d	60	mW
Peak Forward Current(Duty 1/10 @ 1KHZ)	I _{F(Peak)}	160	mA

■ **Electronic Optical Characteristics :**

Parameter	Symbol	Min.	Typ.	Max.	Unit	Condition
Luminous Intensity	I _v	-----	3	-----	mcd	I _F =2mA
Luminous Intensity	I _v	20	48	-----	mcd	I _F =20mA
Viewing Angle	2θ 1/2	-----	130	-----	deg	I _F =20mA
Peak Wavelength	λ _p	-----	632	-----	nm	I _F =20mA
Dominant Wavelength	λ _d	-----	624	-----	nm	I _F =20mA
Spectrum Radiation Bandwidth	△λ	-----	20	-----	nm	I _F =20mA
Forward Voltage	V _F	-----	2.0	2.4	V	I _F =20mA
Reverse Current	I _R	-----	-----	10	μA	V _R =5V



MODEL NO: 12-215SURC/S530-A2/TR8

Device Number : DSE-125-012 REV. 1.1

Chip LEDs with Right Angle Lens

ECN : Page: 4/8

■ Reliability Test Items And Conditions

NO	Item	Test Conditions	Test Hours/Cycle	Sample Size	Ac/Re
1	Solder Heat	TEMP : 260°C ± 5 °C	5 SEC	76 PCS	0/1
2	Temperature Cycle	H : +85°C 30min ∫ 5 min L : -55°C 30min	50 CYCLE	76 PCS	0/1
3	Thermal Shock	H : +100°C 5min ∫ 10 sec L : -10°C 5min	50 CYCLE	76 PCS	0/1
4	High Temperature Storage	TEMP : 100°C	1000 HRS	76 PCS	0/1
5	Low Temperature Storage	TEMP : -55°C	1000 HRS	76 PCS	0/1
6	DC Operating Life	I _F = 20 mA	1000 HRS	76 PCS	0/1
7	High Temperature / High Humidity	85°C/85% RH	1000 HRS	76 PCS	0/1



MODEL NO: 12-215SURC/S530-A2/TR8

Device Number : DSE-125-012 REV. 1.1

Chip LEDs with Right Angle Lens

ECN : Page: 5/8

■ Typical Electro-Optical Characteristic Curves

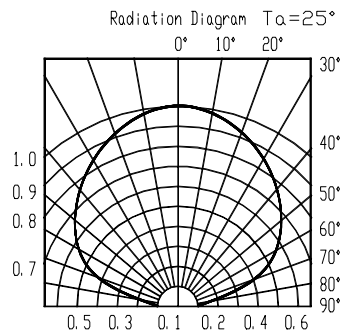
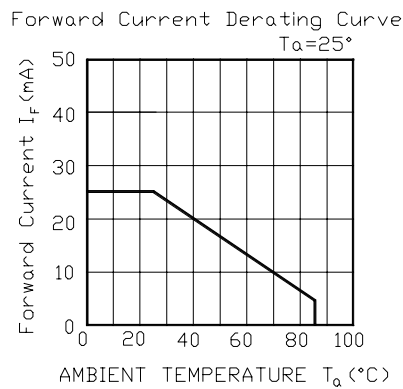
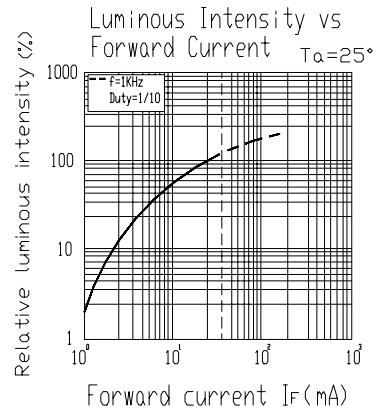
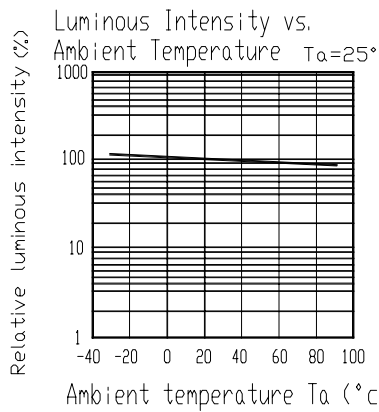
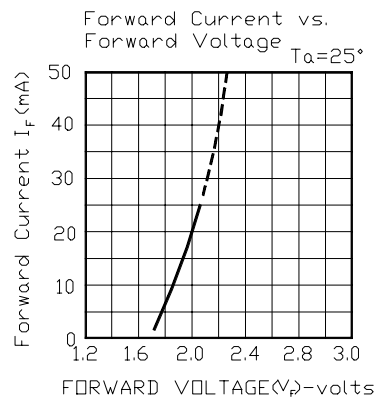
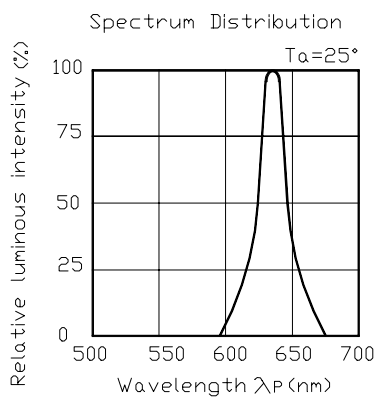



MODEL NO: 12-215SURC/S530-A2/TR8

Device Number : DSE-125-012 REV. 1.1

Chip LEDs with Right Angle Lens

ECN : Page: 6/8

■ Test Circuit

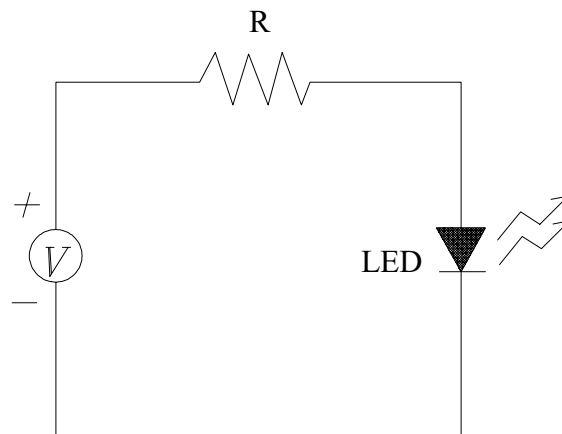

■ Precautions For Use

1. Over-current-proof

Customer must apply resistors for protection , otherwise slight voltage shift will cause big current change (Burn out will happen).

2. Storage time

2.1 The operation of temperature and R.H. are : $5^{\circ}\text{C} \sim 35^{\circ}\text{C}$, R.H.60%.

2.2 Once the package is opened , the products should be used within a week.

Otherwise , they should be keep in a damp proof box with descanting agent.

Considering the tape life , we suggest our customers to use our products within a year(from production date).

2.3 If opened more than one week in an atmosphere $5^{\circ}\text{C} \sim 35^{\circ}\text{C}$, R.H.60% , they should be treated at $60^{\circ}\text{C} \pm 5^{\circ}\text{C}$ for 15hrs.

2.4 When you discover that the desiccant in the package has a pink color (normal=blue) , you should treat them in the same conditions as 2.3.



MODEL NO: 12-215SURC/S530-A2/TR8

Device Number : DSE-125-012 REV. 1.1

Chip LEDs with Right Angle Lens

ECN : Page: 7/8

■ **Soldering heat reliability (DIP)**

Please refer to the following figure :

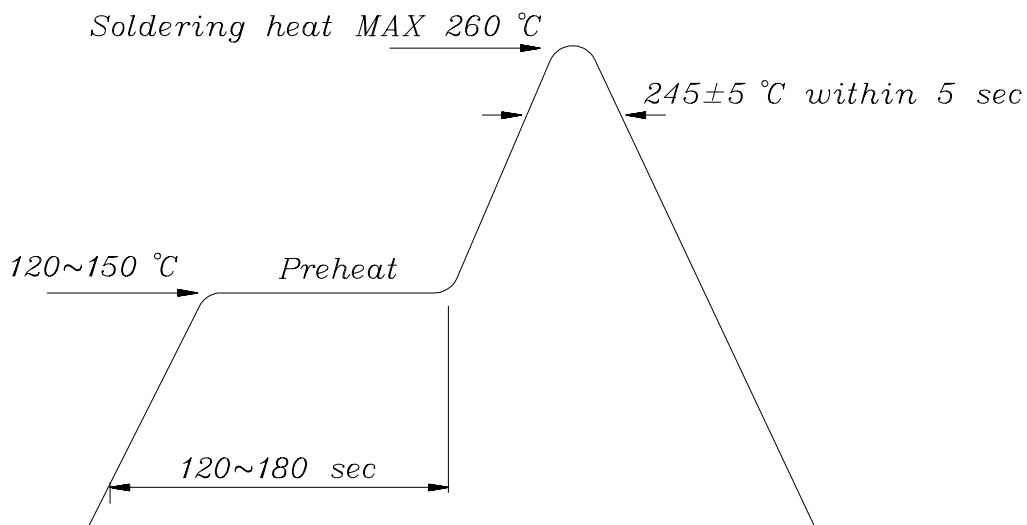

■ **Soldering Iron**

Basic spec is ≤ 5 sec when 260°C .If temperature is higher, time should be shorter (+10°C → -1sec). Power dissipation of iron should be smaller than 15 W , and temperature should be controllable.Surface temperature of the device should be under 230 °C .

■ **Rework**

1. Customer must finish rework within 5 sec under 260°C .
2. Copper foil can not be touched by the head of iron.
3. Twin-head type is preferred.

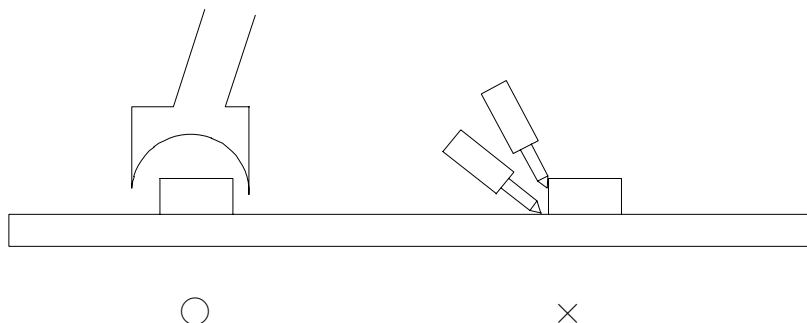



MODEL NO: 12-215SURC/S530-A2/TR8

Device Number : DSE-125-012 REV. 1.1

Chip LEDs with Right Angle Lens

ECN : Page: 8/8

■ Reflow Temp / Time :

