



MODEL NO: 12-21USOC/S530-A4/TR8

Device Number : DSE-121-066 REV. 1.0

**Chip LEDs with Right Angle Lens**

ECN : \_\_\_\_\_ Page: 1/9

**Features :**

- Package in 8mm tape on 7" diameter reel.
- Compatible with automatic placement equipment.
- Compatible with infrared and vapor phase reflow solder process.
- Mono-color type.

**Descriptions :**

- The 12-21 SMD Taping is much smaller than leaded components, thus enable smaller board size, higher packing density, reduced storage space and finally smaller equipment to be obtained.
- Besides, light Weight makes them ideal for miniature application, etc.

**Applications :**

- Automotive: backlighting in dashboards and switches.
- Telecommunication: indicator and backlighting in telephone and fax.
- Flat backlight for LCD, switch and symbol.
- General use.

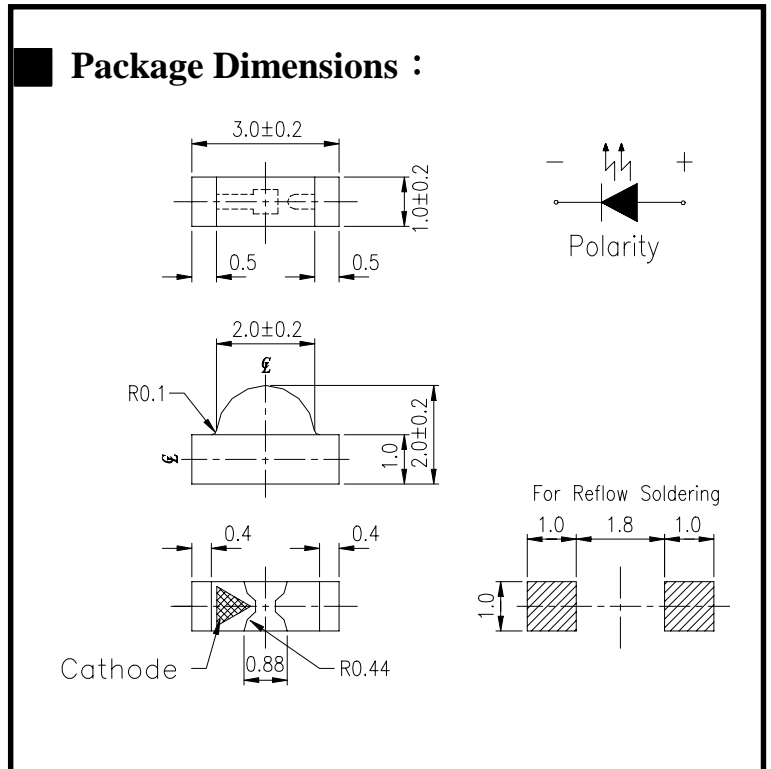

**Notes :**

Tolerances Unless Dimension  $\pm$   
0.1mm  
Angle  $\pm 0.5^\circ$

PART NO	Chip		Lens Color
	Material	Emitted Color	
12-21 USOC/S530-A4/TR8	AlGaInP	Super Sunset Orange	Water Clear

Office: NO. 25, Lane 76, Sec.3, Chung Yang Rd., Tucheng 236, Taipei, Taiwan, R.O.C.

TEL: 886-2-2267-2000, 2267-9936

FAX: 886-2-2267-6244, 2267-6189, 2267-6306

<http://www.everlight.com>



MODEL NO: 12-21USOC/S530-A4/TR8

Device Number : DSE-121-066 REV. 1.0

**Chip LEDs with Right Angle Lens**

ECN : ..... Page: 2/9

■ **Package Dimension :**

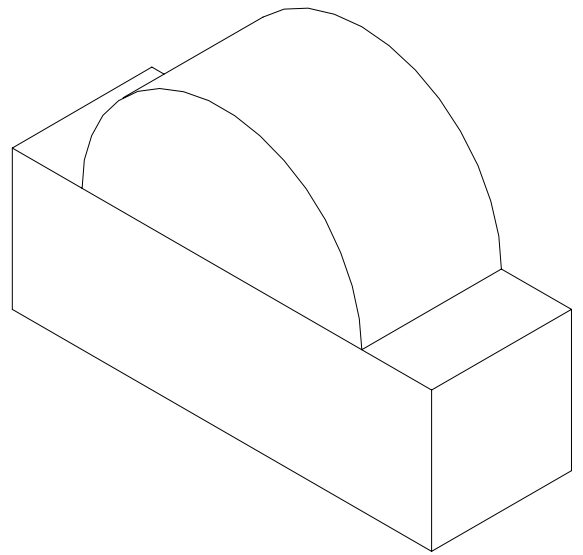
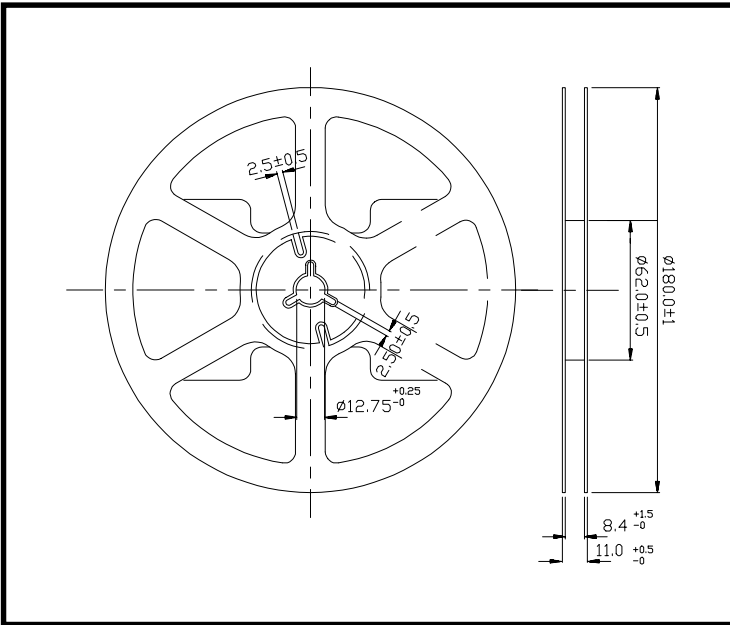

■ **Loaded quantity per reel 2000 PCS/reel :**

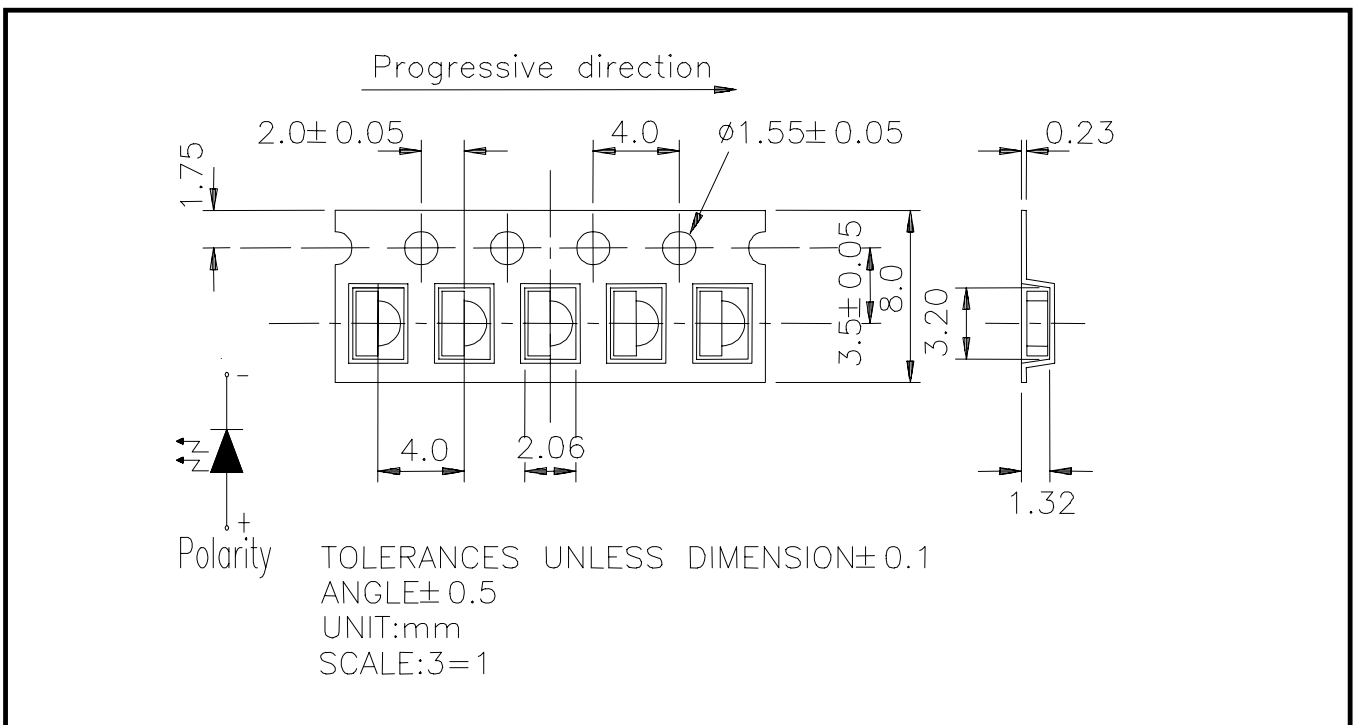



MODEL NO: 12-21USOC/S530-A4/TR8

Device Number : DSE-121-066 REV. 1.0

*Chip LEDs with Right Angle Lens*

ECN : ..... Page: 3/9

■ Absolute Maximum Ratings at Ta = 25°C

Parameter	Symbol	Rating	Unit
Reverse Voltage	V <sub>R</sub>	5	V
Forward Current	I <sub>F</sub>	25	mA
Operating Temperature	T <sub>opr</sub>	-40 ~ +85	°C
Storage Temperature	T <sub>stg</sub>	-40 ~ +90	°C
Soldering Temperature	T <sub>sol</sub>	260 (for 5 second)	°C
Electrostatic Discharge	ESD	2000	V
Power Dissipation	P <sub>d</sub>	60	mW
Peak Forward Current(Duty 1/10 @ 1KHz)	I <sub>F</sub> (Peak)	160	mA



MODEL NO: 12-21USOC/S530-A4/TR8

Device Number : DSE-121-066 REV. 1.0

*Chip LEDs with Right Angle Lens*

ECN : ..... Page: 4/9

■ **Electronic Optical Characteristics :**

Parameter	Symbol	Min.	Typ.	Max.	Unit	Condition
Luminous Intensity	I <sub>v</sub>	----- 65	6 97	-----	mcd	I <sub>F</sub> =2mA I <sub>F</sub> =20mA
Viewing Angle	2θ 1/2	-----	120	-----	deg	I <sub>F</sub> =20mA
Peak Wavelength	λ <sub>p</sub>	-----	621	-----	nm	I <sub>F</sub> =20mA
Dominant Wavelength	λ <sub>d</sub>	-----	615	-----	nm	I <sub>F</sub> =20mA
Spectrum Radiation Bandwidth	Δλ	-----	18	-----	nm	I <sub>F</sub> =20mA
Forward Voltage	V <sub>F</sub>	-----	2.0	2.4	V	I <sub>F</sub> =20mA
Reverse Current	I <sub>R</sub>	-----	-----	10	μA	V <sub>R</sub> =5V



MODEL NO: 12-21USOC/S530-A4/TR8

Device Number : DSE-121-066 REV. 1.0

*Chip LEDs with Right Angle Lens*

ECN : ..... Page: 5/9

■ Reliability Test Items And Condition

NO	Item	Test Conditions	Test Hours/Cycle	Sample Size	Ac/Re
1	Solder Heat	TEMP. : 260°C ± 5 °C	5 SEC.	76 PCS	0/1
2	Temperature Cycle	H : +85°C 30min. ∫ 5 min. L : -55°C 30min.	50 CYCLES	76 PCS	0/1
3	Thermal Shock	H : +100°C 5min. ∫ 10 sec. L : -10°C 5min.	50 CYCLES	76 PCS	0/1
4	High Temperature Storage	TEMP. : 100°C	1000 HR.	76 PCS	0/1
5	High Temperature Storage	TEMP. : -55°C	1000 HR.	76 PCS	0/1
6	DC Operating Life	IF = 20 mA	1000 HR.	76 PCS	0/1
7	High Temperature / High Humidity	85°C/RH85%	1000 HR.	76 PCS	0/1



MODEL NO: 12-21USOC/S530-A4/TR8

Device Number : DSE-121-066 REV. 1.0

*Chip LEDs with Right Angle Lens*

ECN : ..... Page: 6/9

**Typical Electro-Optical Characteristic Curves**

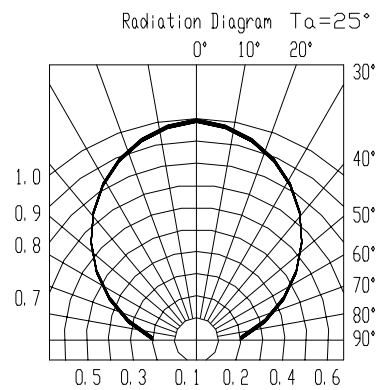
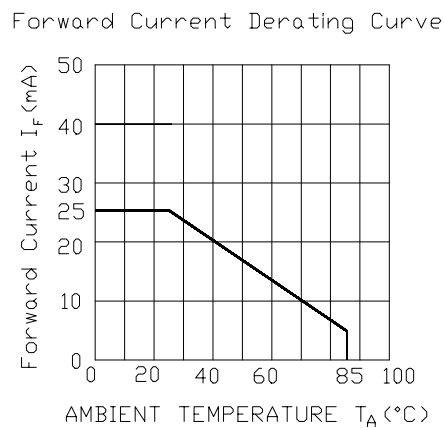
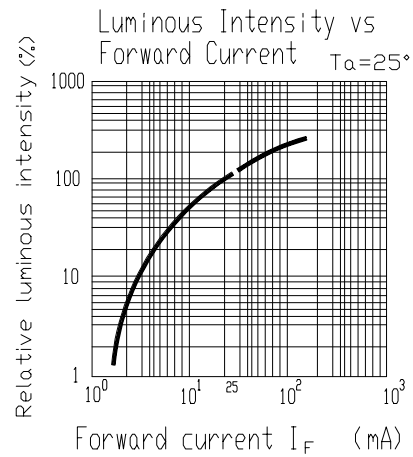
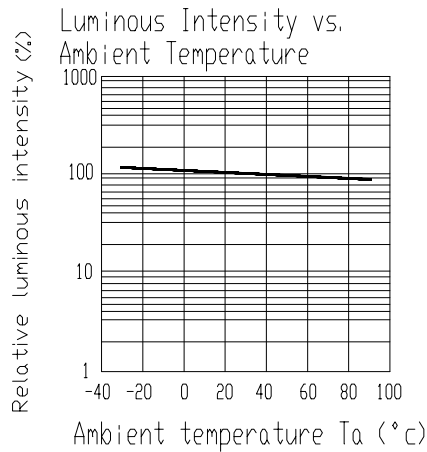
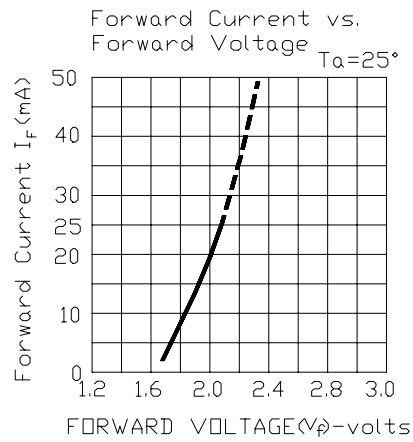
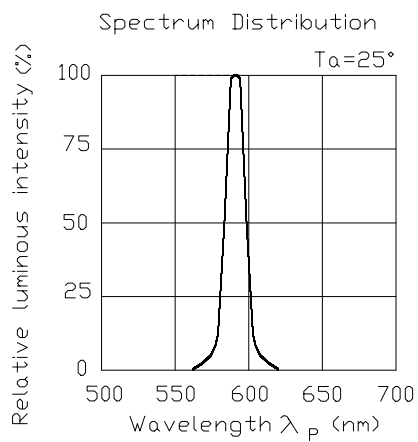



MODEL NO: 12-21USOC/S530-A4/TR8

Device Number : DSE-121-066 REV. 1.0

*Chip LEDs with Right Angle Lens*

ECN : ..... Page: 7/9

### ■ Test Circuit

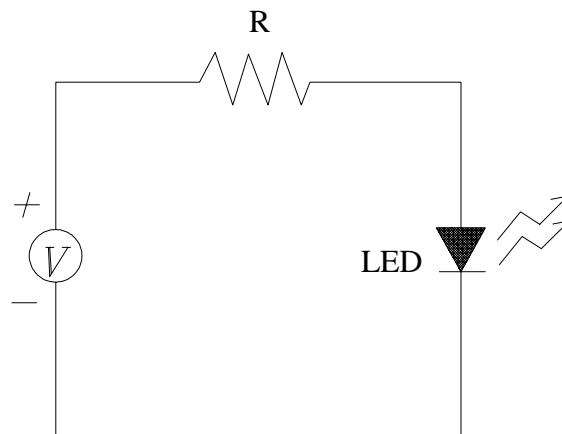

### ■ Precautions For Use

#### 1. Over-current-proof

Customer must apply resistors for protection , otherwise slight voltage shift will cause big current change ( Burn out will happen ).

#### 2. Storage time

2.1 The operation of temperature and R.H. are :  $5^{\circ}\text{C} \sim 35^{\circ}\text{C}$  , R.H.60% .

2.2 Once the package is opened , the products should be used within a week.

Otherwise , they should be keep in a dampproof box with desiccants.

Considering the tape life , we suggest our customers to use our products within a year(from production date).

2.3 If opened more than one week in an atmosphere  $5^{\circ}\text{C} \sim 35^{\circ}\text{C}$  , R.H.60% , they should be treated at  $60^{\circ}\text{C} \pm 5^{\circ}\text{C}$  for 15hrs.

2.4 When you discover that the desiccant in the package has a pink color (normal=blue) , you should treat them in the same conditions as 2.3.

■ **Soldering heat reliability ( DIP )**

Please refer to the following figure :

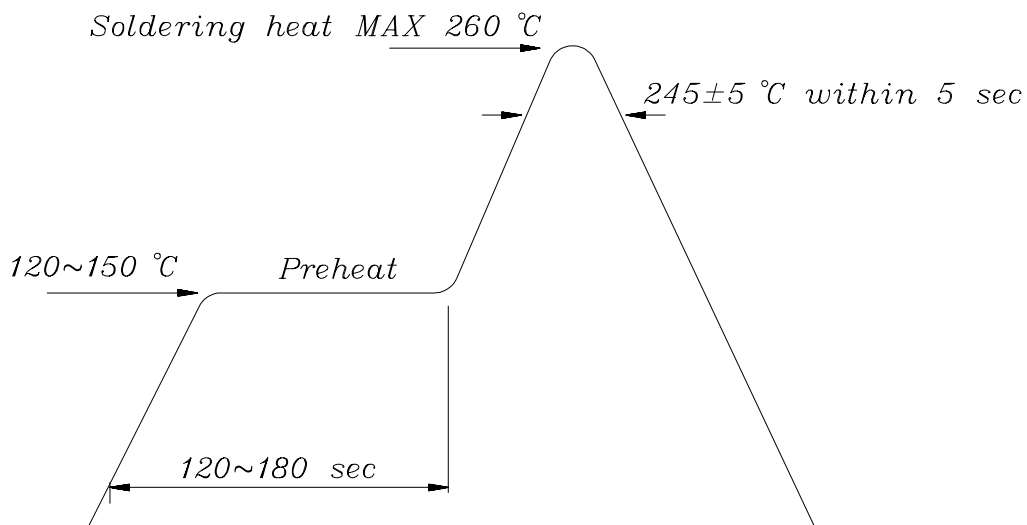

■ **Soldering Iron**

Basic spec is  $\leq 5$  sec when  $260^{\circ}\text{C}$ . If temperature is higher, time should be shorter ( $+10^{\circ}\text{C} \rightarrow -1\text{sec}$ ). Power dissipation of iron should be smaller than 15 W , and temperature should be controllable. Surface temperature of the device should be under  $230^{\circ}\text{C}$ .

■ **Rework**

1. Customer must finish rework within 5 sec under  $260^{\circ}\text{C}$ .
2. Copper foil can not be touched by the head of iron.
3. Twin-head type is preferred.

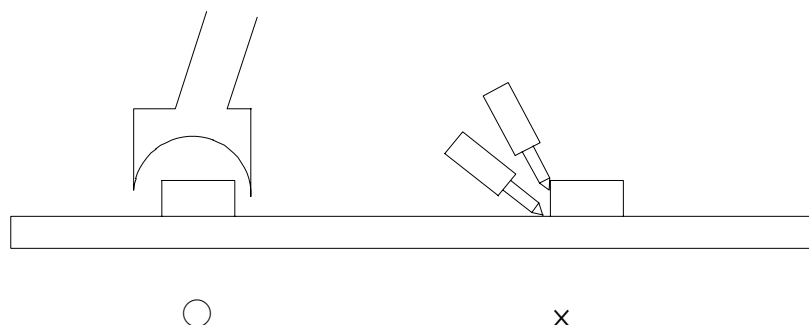





MODEL NO: 12-21USOC/S530-A4/TR8

Device Number : DSE-121-066 REV. 1.0

*Chip LEDs with Right Angle Lens*

ECN : ..... Page: 9/9

■ Reflow Temp / Time :

