



# EVERLIGHT ELECTRONICS CO.,LTD.

Device Number :     DDB-100-029     REV:     1.1    

## 10 Bar Graph Displays

MODEL NO :     ELB-1001EWA     ECN :      Page:     1/5    

### ■ Features :

- Industrial standard size.
- Low power consumption.
- Categorized for luminous intensity.

### ■ Applications:

- Audio equipment
- Instrument panels
- Digital read out display

### ■ Descriptions :

- The ELB-1001 series are ten-element bar graph displays. Design for viewing distances up to 7 meters.
- There are separate anodes and cathodes for each light segment and choice of five colors is offered.
- These device is made with white segments and gray surface.

PART NO	CHIP		C.C. or C.A.
	Material	Emitted Color	
ELB-1001EWA	GaAsP/GaP	Orange	****

OFFICE : NO. 25,Lane 76,Sec.3, Chung Yang Rd., Tucheng 236, Taipei, Taiwan, R.O.C.

TEL : 886-2-2267-2000,2267-9936

FAX : 886-2-2267-6244,22676189,22676306

<http://www.everlight.com>



10 Bar Graph Displays

MODEL NO : ELB-1001EWA ECN : \_\_\_\_\_ Page: 2/5

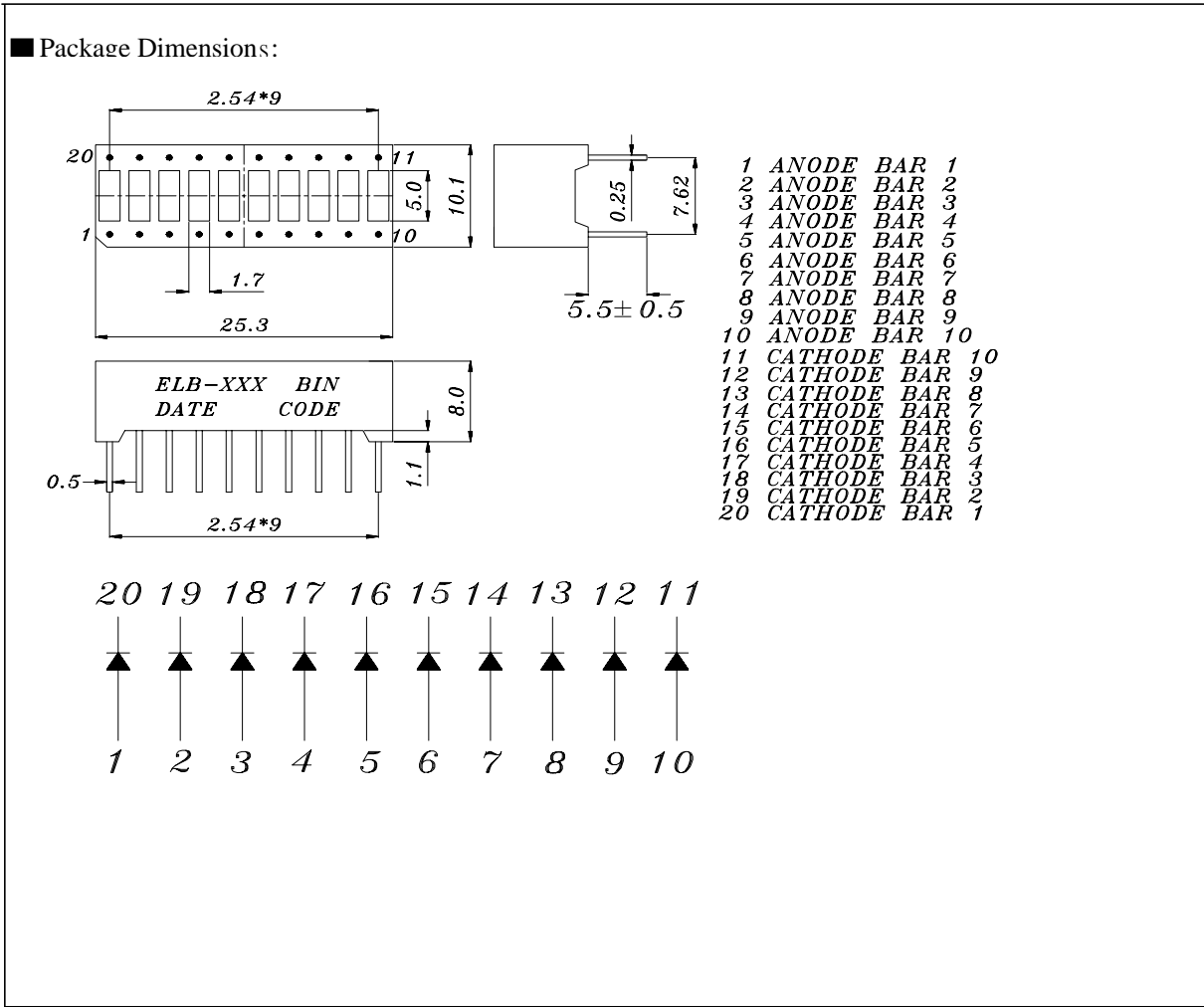

■ NOTES:

- 1.All dimensions are in millimeters tolerance is 0.25mm unless otherwise noted.
  - 2.Above specification may be changed without notice.
- Supplier will reserve authority on material change for above specification.





# EVERLIGHT ELECTRONICS CO.,LTD.

Device Number : DDB-100-029 REV: 1.1

10 Bar Graph Displays

MODEL NO : ELB-1001EWA ECN : \_\_\_\_\_ Page: 4/5

■ Reliability test item and condition:					
NO	Item	Test Conditions	Test Hours/Cycle	Sample Size	Ac/Re
1	Solder Heat	TEMP : 260°C ± 5 °C	5 SEC	76 PCS	0/1
2	Temperature Cycle	H : +85°C 30min ∫ 5 min L : -55°C 30min	50 CYCLE	76 PCS	0/1
3	Thermal Shock	H : +100°C 5min ∫ 10 sec L : -10°C 5min	50 CYCLE	76 PCS	0/1
4	High Temperature Storage	TEMP : 100°C	1000 HRS	76 PCS	0/1
5	Low Temperature Storage	TEMP : -55°C	1000 HRS	76 PCS	0/1
6	DC Operating Life	If = 10 mA	1000 HRS	76 PCS	0/1
7	High Temperature / High Humidity	85°C/85% RH	1000 HRS	76 PCS	0/1





Device Number : DDB-100-029

REV: 1.1

10 Bar Graph Displays

MODEL NO: ELB-1001EWA

ECN :                     

Page: 5/5

## Typical Electro-Optical Characteristic Curves:

E

