



Description

The MK1413 is the ideal way to generate clocks for MPEG audio devices in computers. The device uses MicroClock's proprietary mixture of analog and digital Phase-Locked Loop (PLL) technology to synthesize one of four frequencies from the 14.31818 MHz reference. In an 8 pin SOIC, the MK1413 can save component count, board space, and cost over crystals and oscillators, and increase reliability by eliminating three expensive mechanical devices from the board.

MicroClock offers many other clocks for computers and computer peripherals. Consult MicroClock when you need to remove crystals and oscillators from your board.

Features

- Packaged in 8 pin SOIC 
- Input crystal or clock frequency of 14.31818 MHz
- Provides master MPEG clocks for 32 kHz, 44.1 kHz and 48 kHz sampling rates
- Output clock frequencies of 8.192 MHz, 11.2896 MHz, 12.288 MHz, and 16.9344 MHz
- Low jitter
- 25mA drive capability at TTL levels
- 3.3V or 5V±10% supply voltage
- Advanced, low power CMOS process

Block Diagram

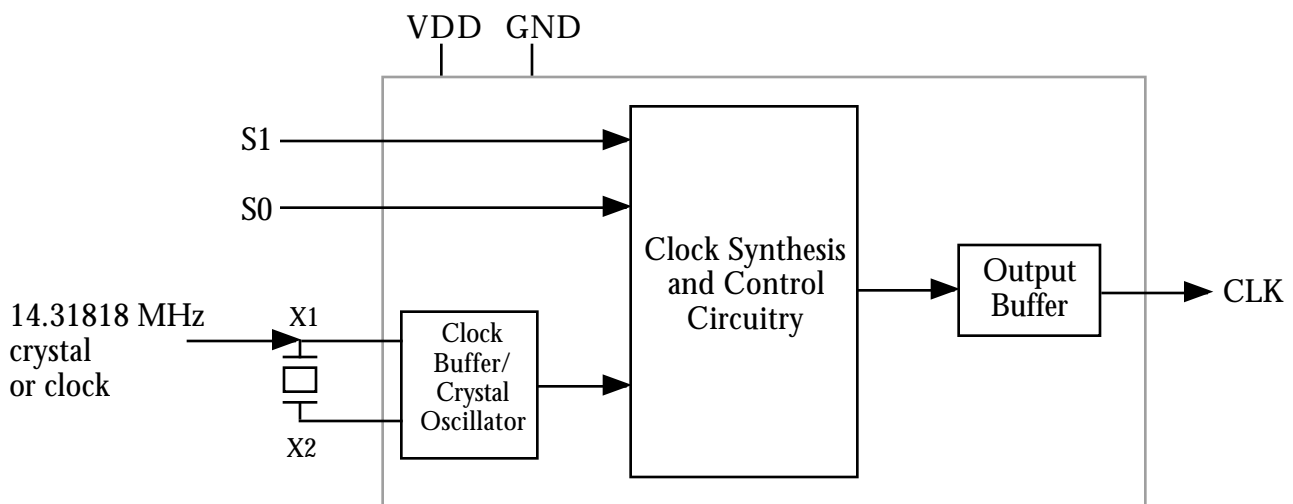

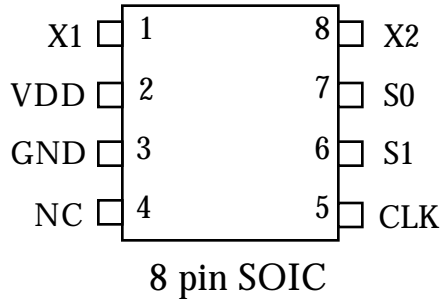

Pin Assignment

**Audio Clock Output Select Table**

S1 pin 6	S0 pin 7	Audio Clock pin 5	Accuracy (ppm)
0	0	8.192 MHz	-2 ppm
0	1	11.2896 MHz	-24 ppm
1	0	12.288 MHz	-2 ppm
1	1	16.9344 MHz	-24 ppm

Pin Descriptions

Number	Name	Type	Description
1	X1	I	Crystal Connection. Connect to a 14.31818 MHz crystal or clock.
2	VDD	P	Connect to +3.3V or +5V.
3	GND	P	Connect to ground.
4	NC	-	No Connect.
5	CLK	O	Audio Clock Output as per table above.
6	S1	I	Frequency Select 1 Input. Determines CLK output as per table above.
7	S0	I	Frequency Select 0 Input. Determines CLK output as per table above.
8	X2	O	Crystal Connection to a 14.31818 MHz crystal, or leave unconnected for clock input.

Key: I = Input, O = output, P = power supply connection

External Components/Crystal Selection

A minimum number of external components are required for proper oscillation. For a crystal input, one load capacitor should be connected to each of the X1 and X2 pins and ground, and a parallel resonant 14.31818 MHz crystal is recommended. The value (in pF) of each crystal load capacitor should equal $(C_L - 4) * 2$, where C_L is the crystal's load (correlation) capacitance in pF. The frequency tolerance of the crystal should be 50ppm or better. For a clock input, connect to X1 and leave X2 unconnected. A decoupling capacitor of 0.1µF should be connected between VDD and GND on pins 2 and 3, and 33 terminating resistor may be used on the clock output if the trace is longer than 1 inch.



Electrical Specifications

Parameter	Conditions	Minimum	Typical	Maximum	Units
ABSOLUTE MAXIMUM RATINGS (note 1)					
Supply Voltage, VDD	Referenced to GND			7	V
Inputs	Referenced to GND	-0.5		VDD+.5V	V
Clock Outputs	Referenced to GND	-0.5		VDD+.5V	V
Ambient Operating Temperature		0		70	°C
Soldering Temperature	Max of 10 seconds			260	°C
Storage temperature		-65		150	°C
DC CHARACTERISTICS (at 5.0V unless otherwise noted)					
Operating Voltage, VDD		3		5.5	V
Input High Voltage, VIH, input clock only	Clock input	(VDD/2)+1	VDD/2		V
Input Low Voltage, VIL, input clock only	Clock input		VDD/2	(VDD/2)-1	V
Output High Voltage, VOH	IOH=-4mA	VDD-0.4			V
Output High Voltage, VOH	IOH=-25mA	2.4			V
Output Low Voltage, VOL	IOL=25mA			0.4	V
Operating Supply Current, IDD, 5V	No Load		12		mA
Operating Supply Current, IDD, 3.3V	No Load		7		mA
Input Capacitance	S0, S1 pins		7		pF
Actual Mean Frequency versus Target	With exact crystal			25	ppm
AC CHARACTERISTICS (at 5.0V unless otherwise noted)					
Input Clock or Crystal Frequency			14.31818		MHz
Input Crystal Accuracy				50	ppm
Input Clock Duty Cycle	Time above VDD/2	20		80	%
Output Clock Rise Time	0.8 to 2.0V			1.5	ns
Output Clock Fall Time	2.0 to 0.8V			1.5	ns
Output Clock Duty Cycle	Time above VDD/2	40	50	60	%
Absolute Clock Period Jitter			200		ps
One Sigma Clock Period Jitter			70		ps

Notes:

- Stresses beyond those listed under Absolute Maximum Ratings could cause permanent damage to the device. Prolonged exposure to levels above the operating limits but below the Absolute Maximums may affect device reliability.
- Typical values are at 25°C.

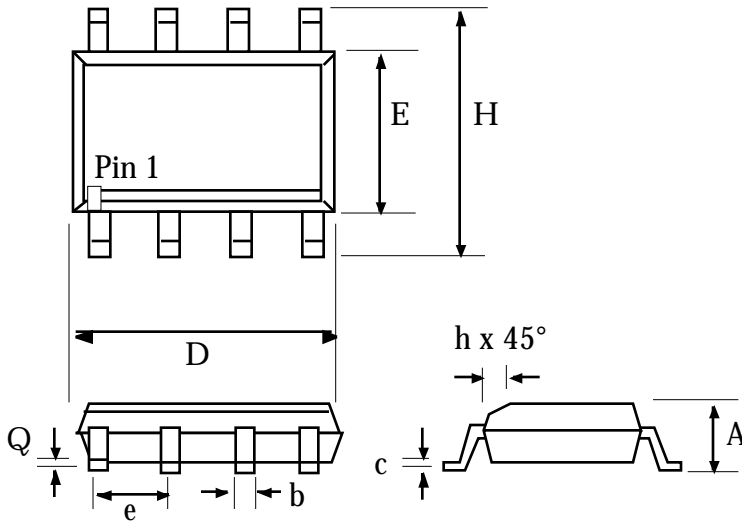
**Package Outline and Package Dimensions****8 pin SOIC**

Symbol	Inches		Millimeters	
	Min	Max	Min	Max
A	0.055	0.068	1.397	1.7272
b	0.013	0.019	0.330	0.483
D	0.185	0.200	4.699	5.080
E	0.150	0.160	3.810	4.064
H	0.225	0.245	5.715	6.223
e	.050 BSC		1.27 BSC	
h		0.015		0.381
Q	0.004	0.01	0.102	0.254

Ordering Information

Part/Order Number	Marking	Package	Temperature
MK1413S	MK1413S	8 pin SOIC	0-70°C
MK1413STR	MK1413S	Add tape and reel	0-70°C

While the information presented herein has been checked for both accuracy and reliability, MicroClock Incorporated assumes no responsibility for either its use or for the infringement of any patents or other rights of third parties, which would result from its use. No other circuits, patents, or licenses are implied. This product is intended for use in normal commercial applications. Any other applications such as those requiring extended temperature range, high reliability, or other extraordinary environmental requirements are not recommended without additional processing by MicroClock. MicroClock reserves the right to change any circuitry or specifications without notice. MicroClock does not authorize or warrant any MicroClock product for use in life support devices or critical medical instruments.