

***Digitally Controlled Potentiometer (XDCP™)***

The Intersil X9116 is a digitally controlled nonvolatile potentiometer designed to be used in trimmer applications. The pot consists of 15 equal resistor segments that connect to the wiper pin through programmable CMOS switches. The tap position is programmed through a 3-wire up/down serial port. The last position of the wiper is stored in a nonvolatile memory location which is recalled at the time of power up of the device.

The wiper moves through sequential tap positions with inputs on the serial port. A falling edge on INC (bar) causes the tap position to increment one position up or down based on whether the U/D (bar) pin is held high or low.

The X9116 can be used in many applications requiring a variable resistance. In many cases it can replace a mechanical trimmer and offers many advantages such as temperature and time stability as well as the reliability of a solid state solution.

**Features**

- Solid-state nonvolatile
- 16 wiper taps
- 3-wire up/down serial interface
- $V_{CC} = 2.7V$  and  $5V$
- Active current  $< 50\mu A$  max.
- Standby current  $< 1\mu A$  max.
- $R_{TOTAL} = 10k\Omega$
- Packages: MSOP-8, SOIC
- Pb-free plus anneal available (RoHS compliant)

**Pinout**

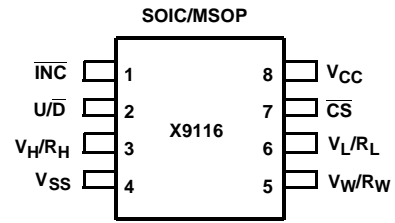

**Block Diagram**

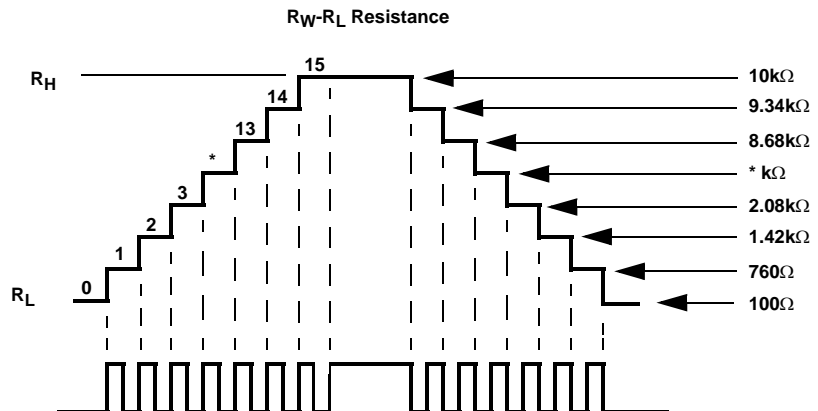
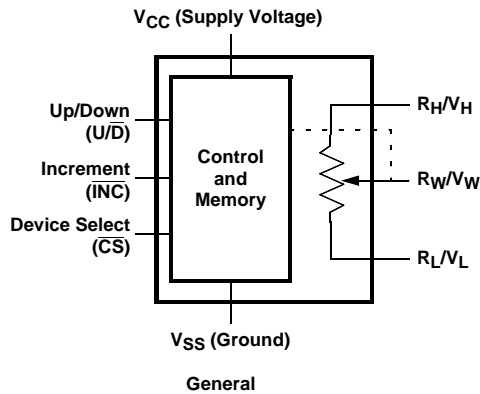

## Ordering Information

PART NUMBER (BRAND)	PART MARKING	V <sub>CC</sub> LIMITS (V)	R <sub>TOTAL</sub> (kΩ)	TEMPERATURE RANGE (°C)	PACKAGE
X9116WM8*	AAZ	5V ±10%	10	0 to 70	8 Ld MSOP
X9116WM8Z* (Note)	AKY			0 to 70	8 Ld MSOP (Pb-free)
X9116WM8I*	AFL			-40 to 85	8 Ld MSOP
X9116WM8IZ* (Note)	DCG			-40 to 85	8 Ld MSOP (Pb-free)
X9116WS8*	X9116W			0 to 70	8 Ld SOIC
X9116WS8Z* (Note)	X9116W Z			0 to 70	8 Ld SOIC (Pb-free)
X9116WS8I*	X9116W I			-40 to 85	8 Ld SOIC
X9116WS8IZ* (Note)	X9116W Z I			-40 to 85	8 Ld SOIC (Pb-free)
X9116WM8-2.7*	AFK	-2.7-5.5	10	0 to 70	8 Ld MSOP
X9116WM8Z-2.7* (Note)	AOJ			0 to 70	8 Ld MSOP (Pb-free)
X9116WM8I-2.7*	ABA			-40 to 85	8 Ld MSOP
X9116WM8IZ-2.7* (Note)	AKS			-40 to 85	8 Ld MSOP (Pb-free)
X9116WS8-2.7*	X9116W F			0 to 70	8 Ld SOIC
X9116WS8Z-2.7* (Note)	X9116W Z F			0 to 70	8 Ld SOIC (Pb-free)
X9116WS8I-2.7*	X9116W G			-40 to 85	8 Ld SOIC
X9116WS8IZ-2.7* (Note)	X9116W Z G			-40 to 85	8 Ld SOIC (Pb-free)

NOTE: Intersil Pb-free plus anneal products employ special Pb-free material sets; molding compounds/die attach materials and 100% matte tin plate termination finish, which are RoHS compliant and compatible with both SnPb and Pb-free soldering operations. Intersil Pb-free products are MSL classified at Pb-free peak reflow temperatures that meet or exceed the Pb-free requirements of IPC/JEDEC J STD-020.

\*Add "T1" suffix for tape and reel.

## Pin Descriptions

### V<sub>H</sub>/R<sub>H</sub> and V<sub>L</sub>/R<sub>L</sub>

The high (V<sub>H</sub>/R<sub>H</sub>) and low (V<sub>L</sub>/R<sub>L</sub>) terminals of the X9116 are equivalent to the fixed terminals of a mechanical potentiometer. The minimum voltage is V<sub>SS</sub> and the maximum is V<sub>CC</sub>.

### V<sub>W</sub>/R<sub>W</sub>

R<sub>W</sub>/R<sub>W</sub> is the wiper terminal and is equivalent to the movable terminal of a mechanical potentiometer. The position of the wiper within the array is determined by the control inputs. The wiper terminal series resistance is typically 200Ω to 400Ω depending upon V<sub>CC</sub>.

### Up/Down (U/D)

The U/D input controls the direction of the wiper movement and whether the counter is incremented (up) or decremented (down).

### Increment (INC)

The INC input is negative-edge triggered. Toggling INC will move the wiper and either increment or decrement the counter in the direction indicated by the logic level on the U/D input.

### Chip Select (CS)

The device is selected when the CS input is LOW. The current counter value is stored in nonvolatile memory when CS is returned HIGH while the INC input is also HIGH. After the store operation is complete the X9116 will be placed in the low power standby mode until the device is selected once again.

## Pin Descriptions

SYMBOL	DESCRIPTION
V <sub>H</sub> /R <sub>H</sub>	High Terminal
V <sub>W</sub> /R <sub>W</sub>	Wiper Terminal
V <sub>L</sub> /R <sub>L</sub>	Low Terminal
V <sub>SS</sub>	Ground
V <sub>CC</sub>	Supply Voltage
U/D	Up/Down Control Input
INC	Increment Control Input
CS	Chip Select Input

## Principles of Operation

There are three sections of the X9116: the input control, counter and decode section; the nonvolatile memory; and

the resistor array. The input control section operates just like an up/down counter. The output of this counter is decoded to turn on a single electronic switch connecting a point on the resistor array to the wiper output. Under the proper conditions the contents of the counter can be stored in nonvolatile memory and retained for future use. The resistor array is comprised of 15 individual resistors connected in series. At either end of the array and between each resistor is an electronic switch that transfers the potential at that point to the wiper pin.

The wiper, when at either fixed terminal, acts like its mechanical equivalent and does not move beyond the last position. That is, the counter does not wrap around when clocked to either extreme.

The electronic switches on the device operate in a “make before break” mode when the wiper changes tap positions. If the wiper is moved several positions, multiple taps are connected to the wiper for  $t_{IW}$  ( $\overline{INC}$  to  $V_W$  change). The  $R_{TOTAL}$  value for the device can temporarily be reduced by a significant amount if the wiper is moved several positions.

When the device is powered-down, the last wiper position stored will be maintained in the nonvolatile memory. When power is restored, the contents of the memory are recalled and the wiper is set to the value last stored.

### Instructions and Programming

The  $\overline{INC}$ ,  $\overline{U/D}$  and  $\overline{CS}$  inputs control the movement of the wiper along the resistor array. With  $\overline{CS}$  set LOW, the device is selected and enabled to respond to the  $\overline{U/D}$  and  $\overline{INC}$  inputs. HIGH to LOW transitions on  $\overline{INC}$  will increment or decrement (depending on the state of the  $\overline{U/D}$  input) a four bit counter. The output of this counter is decoded to select one of 16 wiper positions along the resistive array.

The value of the counter is stored in nonvolatile memory whenever  $\overline{CS}$  transitions HIGH while the  $\overline{INC}$  input is also HIGH.

The system may select the X9116, move the wiper, and deselect the device without having to store the latest wiper position in nonvolatile memory. After the wiper movement is performed as described above and once the new position is reached, the system must keep  $\overline{INC}$  LOW while taking  $\overline{CS}$  HIGH. The new wiper position will be maintained until changed by the system or until a power-up/down cycle recalls the previously stored data.

This procedure allows the system to always power-up to a preset value stored in nonvolatile memory; then during system operation, minor adjustments could be made. The adjustments might be based on user preference, system parameter changes due to temperature drift, etc.

The state of  $\overline{U/D}$  may be changed while  $\overline{CS}$  remains LOW. This allows the host system to enable the device and then move the wiper up and down until the proper trim is attained.

### Mode Selection

$\overline{CS}$	$\overline{INC}$	$\overline{U/D}$	MODE
L		H	Wiper Up
L		L	Wiper Down
	H	X	Store Wiper Position
H	X	X	Standby Current
	L	X	No Store, Return to Standby

### Symbol Table

WAVEFORM	INPUTS	OUTPUTS
	Must be steady	Will be steady
	May change from Low to High	Will change from Low to High
	May change from High to Low	Will change from High to Low
	Don't Care: Changes Allowed	Changing: State Not Known
	N/A	Center Line is High Impedance

**Absolute Maximum Ratings**

Temperature under bias . . . . . -65°C to +135°C  
 Storage temperature . . . . . -65°C to +150°C  
 Voltage on CS, INC, U/D, V<sub>H</sub>/R<sub>H</sub>, V<sub>L</sub>/R<sub>L</sub>  
 and V<sub>CC</sub> with respect to V<sub>SS</sub> . . . . . -1V to +7V  
 $\Delta V = |V_H/R_H - V_L/R_L|$  . . . . . 5.5V  
 Lead temperature (soldering, 10 seconds) . . . . . 300°C  
 I<sub>W</sub> (10 seconds) . . . . . ±10.0mA

**Recommended Operating Conditions**

Temperature Range  
 Commercial . . . . . 0°C to +70°C  
 Industrial . . . . . -40°C to +85°C  
 Supply Voltage (V<sub>CC</sub>) Limits  
 X9116 . . . . . 5V ± 10%  
 X9116-2.7 . . . . . 2.7V to 5.5V

*CAUTION: Stresses above those listed in "Absolute Maximum Ratings" may cause permanent damage to the device. This is a stress only rating and operation of the device at these or any other conditions above those indicated in the operational sections of this specification is not implied.*

**Potentiometer Specifications** Over recommended operating conditions unless otherwise stated

SYMBOL	PARAMETER	TEST CONDITIONS/NOTES	MIN	TYP	MAX	UNIT
R <sub>TOTAL</sub>	End to end resistance variation		-20		+20	%
V <sub>VH</sub>	V <sub>H</sub> /R <sub>H</sub> terminal voltage	V <sub>SS</sub> = 0V	V <sub>SS</sub>		V <sub>CC</sub>	V
V <sub>VL</sub>	V <sub>L</sub> /R <sub>L</sub> terminal voltage	V <sub>SS</sub> = 0V	V <sub>SS</sub>		V <sub>CC</sub>	V
	Power rating	R <sub>TOTAL</sub> = 10kΩ			10	mW
R <sub>W</sub>	Wiper resistance	I <sub>W</sub> = 1mA, V <sub>CC</sub> = 5V		200	400	Ω
R <sub>W</sub>	Wiper resistance	I <sub>W</sub> = 1mA, V <sub>CC</sub> = 2.7V		400	1000	Ω
I <sub>W</sub>	Wiper current		-5.0		+5.0	mA
	Noise	Ref: 1kHz		-120		dBV√Hz
	Resolution			6		%
	Absolute linearity (Note 1)	V <sub>w(n)(actual)</sub> - V <sub>w(n)(expected)</sub>	-1		+1	MI (Note 3)
	Relative linearity (Note 2)	V <sub>w(n+1)</sub> - [V <sub>w(n)</sub> + MI]	-0.2		+0.2	MI (Note 3)
	R <sub>TOTAL</sub> temperature coefficient			±300		ppm/°C
	Ratiometric temperature coefficient				±20	ppm/°C
C <sub>H</sub> /C <sub>L</sub> /C <sub>W</sub>	Potentiometer capacitances	See Circuit #3		10/10/25		pF

NOTES:

1. Absolute linearity is utilized to determine actual wiper voltage versus expected voltage = (V<sub>w(n)(actual)</sub> - V<sub>w(n)(expected)</sub>) = ±1 MI Maximum.
2. Relative linearity is a measure of the error in step size between taps = V<sub>w(n+1)</sub> - [V<sub>w(n)</sub> + MI] = ±0.2 MI.
3. 1 MI = Minimum Increment = R<sub>TOT</sub>/15.

**DC Electrical Specifications** Over recommended operating conditions unless otherwise specified

SYMBOL	PARAMETER	TEST CONDITIONS	MIN	TYP (Note 4)	MAX	UNIT
I <sub>CC1</sub>	V <sub>CC</sub> active current (Increment)	$\overline{CS} = V_{IL}$ , $U/\overline{D} = V_{IL}$ or $V_{IH}$ and $\overline{INC} = 0.4V/2.4V @ \max t_{CYC}$			150	μA
I <sub>CC2</sub>	V <sub>CC</sub> active current (Store) (EEPROM Store)	$\overline{CS} = V_{IH}$ , $U/\overline{D} = V_{IL}$ or $V_{IH}$ and $\overline{INC} = V_{IH} @ \max t_{WR}$			400	μA
I <sub>SB</sub>	Standby supply current	$\overline{CS} = V_{CC}-0.3V$ , $U/\overline{D}$ and $\overline{INC} = V_{SS}$ or $V_{CC}-0.3V$			1	μA
I <sub>LI</sub>	$\overline{CS}$ , $\overline{INC}$ , $U/\overline{D}$ input leakage current	$V_{IN} = V_{SS}$ to $V_{CC}$			±10	μA
V <sub>IH</sub>	$\overline{CS}$ , $\overline{INC}$ , $U/\overline{D}$ input HIGH voltage		2V		V <sub>CC</sub> + 0.5	V
V <sub>IL</sub>	$\overline{CS}$ , $\overline{INC}$ , $U/\overline{D}$ input LOW voltage		-0.5		0.8	V
C <sub>IN</sub> (Note 5)	$\overline{CS}$ , $\overline{INC}$ , $U/\overline{D}$ input capacitance	$V_{CC} = 5V$ , $V_{IN} = V_{SS}$ , $T_A = 25^\circ C$ , $f = 1MHz$			10	pF

4. Typical values are for T<sub>A</sub> = 25°C and nominal supply voltage.

5. This parameter is periodically sampled and not 100% tested.

**Endurance And Data Retention**

PARAMETER	MIN	UNIT
Minimum endurance	100,000	Data changes per bit
Data retention	100	Years

**Test Circuit #1**

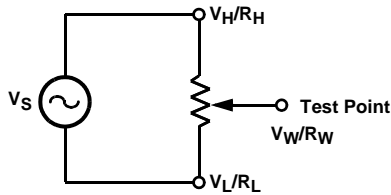

**Test Circuit #2**

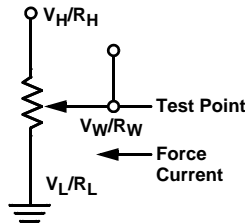

**Circuit #3 SPICE Macro Model**

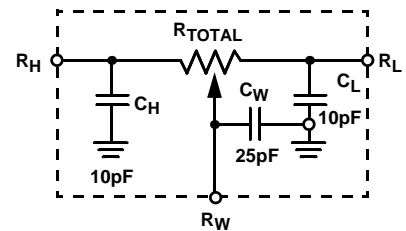

**A.C. Conditions of Test**

Input pulse levels	0V to 3V
Input rise and fall times	10ns
Input reference levels	1.5V

**DC Electrical Specifications** Over recommended operating conditions unless otherwise specified

SYMBOL	PARAMETER	MIN	TYP (NOTE 6)	MAX	UNIT
$t_{CI}$	$\overline{CS}$ to $\overline{INC}$ setup	100			ns
$t_{ID}$	$\overline{INC}$ HIGH to $U/\overline{D}$ change	100			ns
$t_{DI}$	$U/\overline{D}$ to $\overline{INC}$ setup	2.9			$\mu$ s
$t_{IL}$	$\overline{INC}$ LOW period	1			$\mu$ s
$t_{IH}$	$\overline{INC}$ HIGH period	1			$\mu$ s
$t_{IC}$	$\overline{INC}$ inactive to $\overline{CS}$ inactive	1			$\mu$ s
$t_{CPH}$	$\overline{CS}$ deselect time (STORE)	10			ms
$t_{IW}$	$\overline{INC}$ to $V_W$ change		1	5	$\mu$ s
$t_{CYC}$	$\overline{INC}$ cycle time	4			$\mu$ s
$t_R, t_F$ (Note 7)	$\overline{INC}$ input rise and fall time			500	$\mu$ s
$t_{PU}$ (Note 7)	Power up to wiper stable			5	$\mu$ s
$t_R V_{CC}$ (Note 7)	$V_{CC}$ Power-up rate	15		50	mV/ $\mu$ s
$t_{WR}$	Store cycle		5	10	ms

**Power Up and Down Requirements**

There are no restrictions on the power-up or power-down conditions of  $V_{CC}$  and the voltages applied to the potentiometer pins provided that  $V_{CC}$  is always more positive than or equal to  $V_H, V_L,$  and  $V_W$ , i.e.,  $V_{CC} \geq V_H, V_L, V_W$ . The  $V_{CC}$  ramp rate spec is always in effect.

**A.C. Timing**

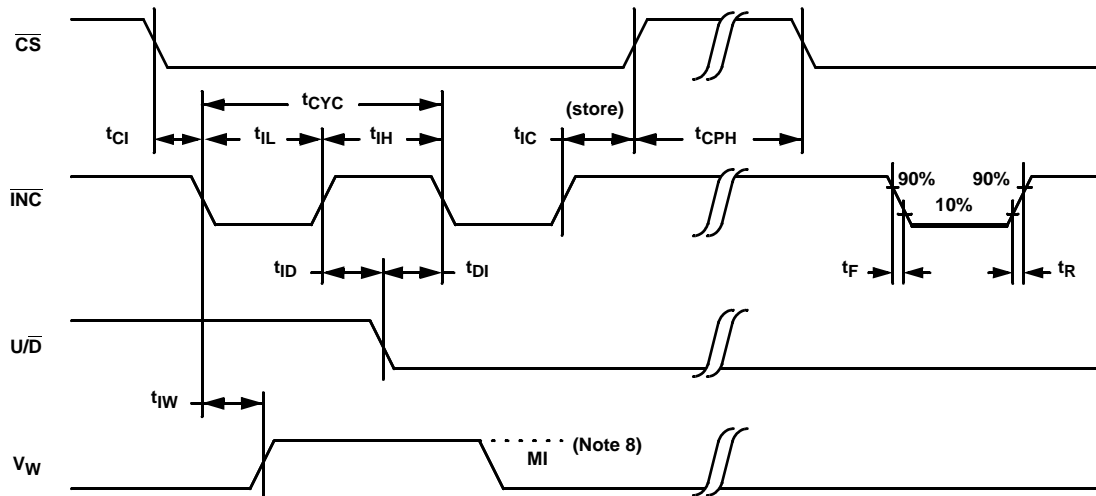

NOTES:

- 6. Typical values are for  $T_A = 25^\circ\text{C}$  and nominal supply voltage.
- 7. This parameter is not 100% tested.
- 8. MI in the A.C. timing diagram refers to the minimum incremental change in the  $V_W$  output due to a change in the wiper position.

Basic Configurations of Electronic Potentiometers

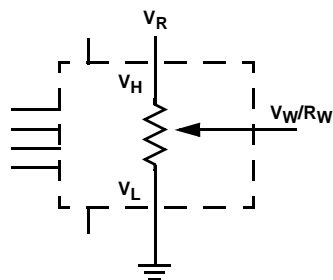

Three terminal potentiometer; variable voltage divider

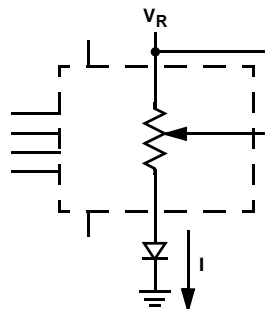

Two terminal variable resistor; variable current

Basic Circuits

Buffered Reference Voltage

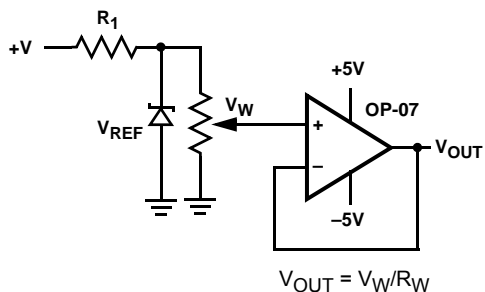

Cascading Techniques

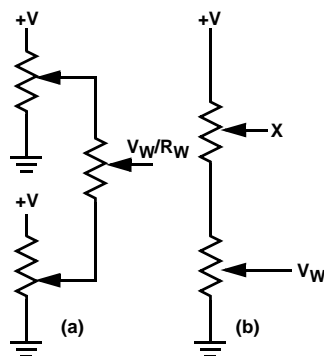

Noninverting Amplifier

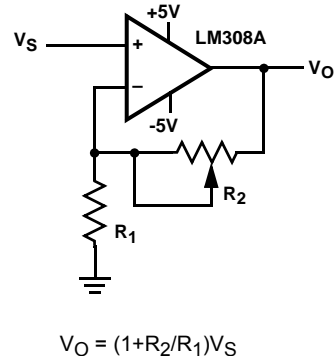

Voltage Regulator

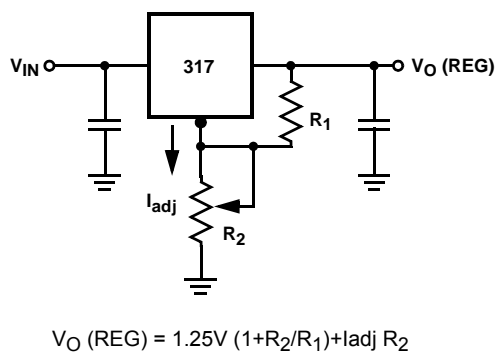

Comparator with Hysteresis

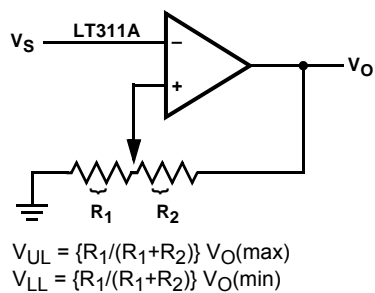

(for additional circuits see AN115)

Packaging information

8-Lead Miniature Small Outline Gull Wing Package Type M

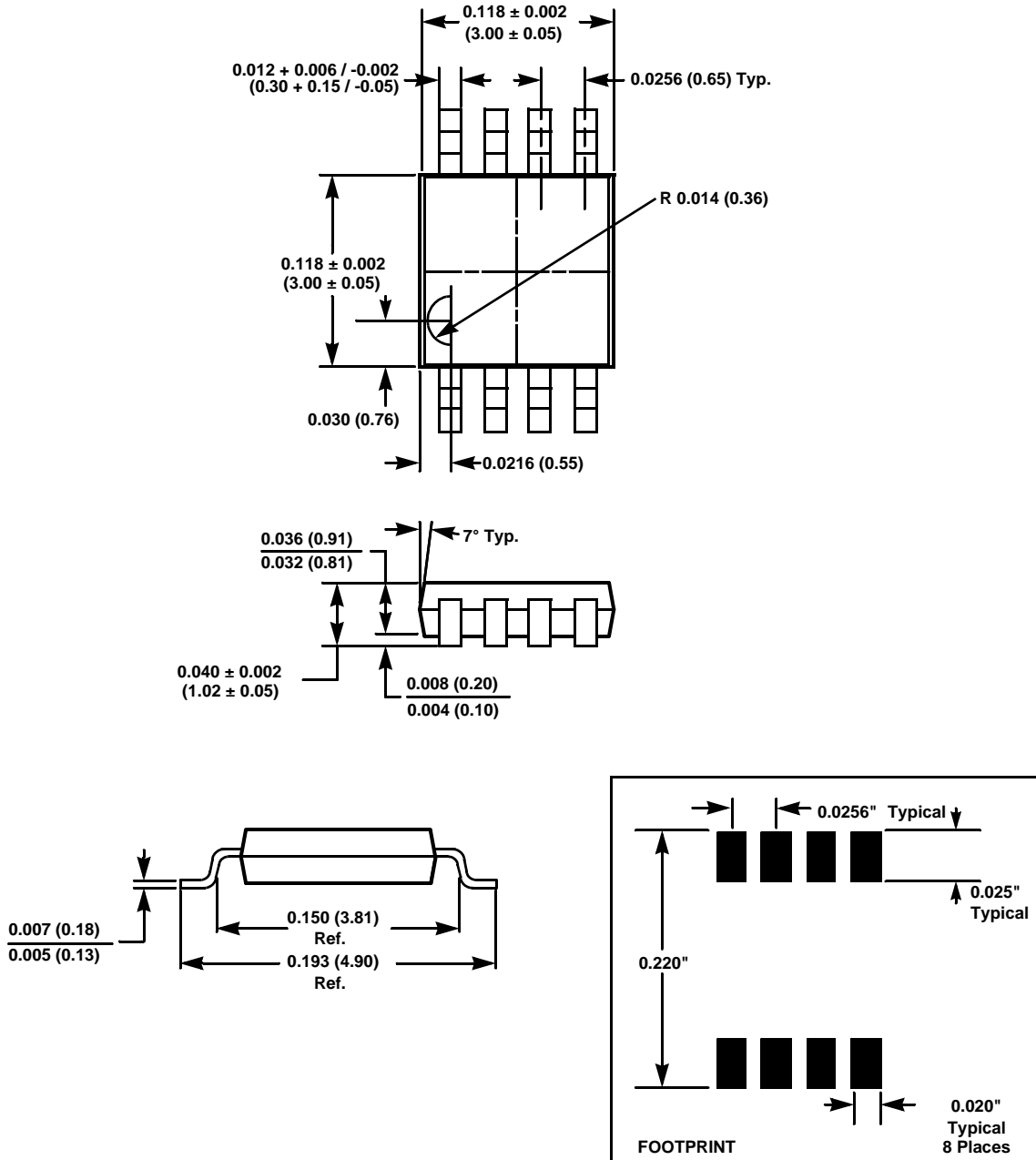

NOTE:

1. ALL DIMENSIONS IN INCHES AND (MILLIMETERS)



Packaging Information

8-Lead Plastic Small Outline Gull Wing Package Type S

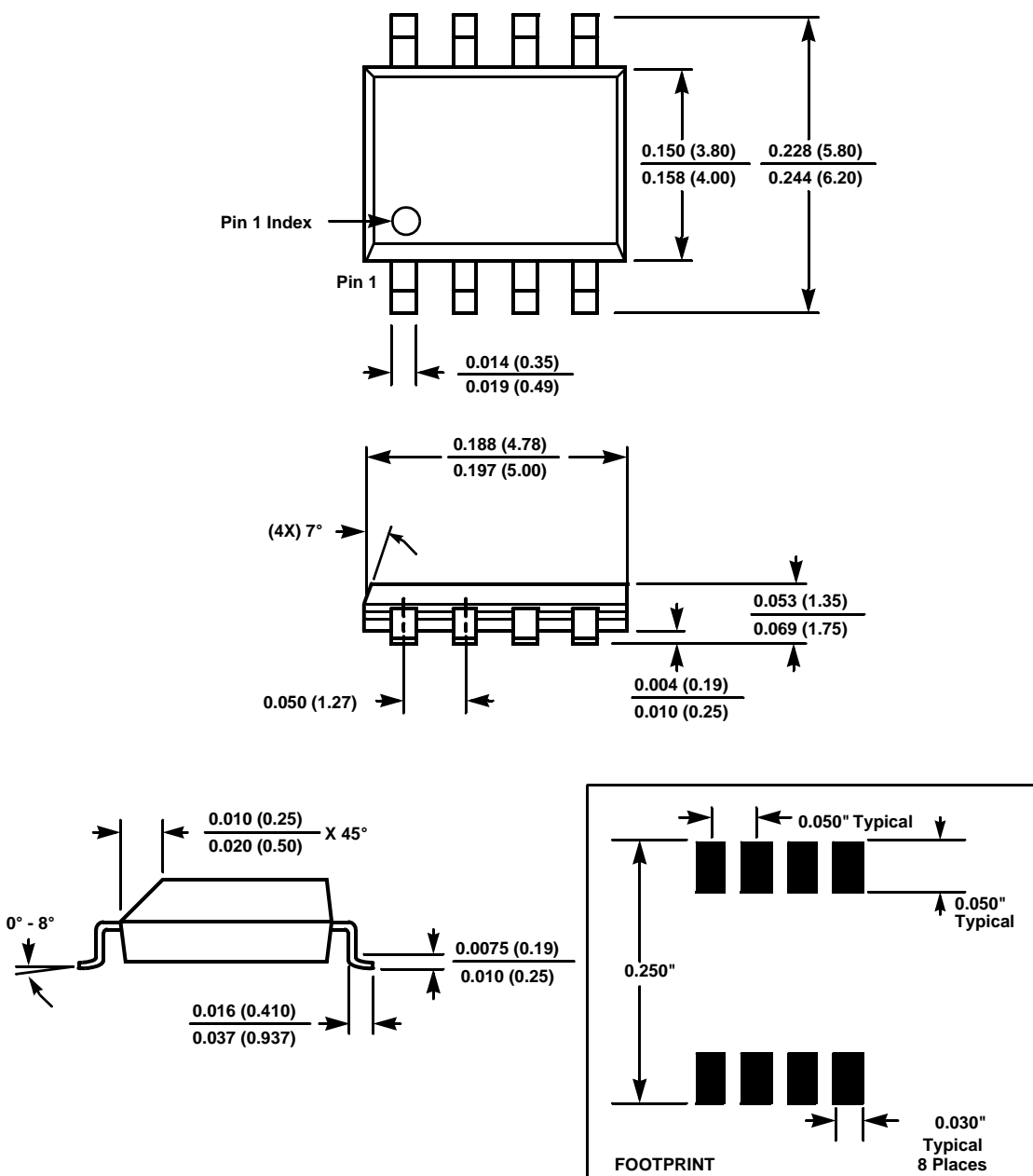

NOTE: ALL DIMENSIONS IN INCHES (IN PARENTHESES IN MILLIMETERS)

All Intersil U.S. products are manufactured, assembled and tested utilizing ISO9000 quality systems. Intersil Corporation's quality certifications can be viewed at [www.intersil.com/design/quality](http://www.intersil.com/design/quality)

*Intersil products are sold by description only. Intersil Corporation reserves the right to make changes in circuit design, software and/or specifications at any time without notice. Accordingly, the reader is cautioned to verify that data sheets are current before placing orders. Information furnished by Intersil is believed to be accurate and reliable. However, no responsibility is assumed by Intersil or its subsidiaries for its use; nor for any infringements of patents or other rights of third parties which may result from its use. No license is granted by implication or otherwise under any patent or patent rights of Intersil or its subsidiaries.*

For information regarding Intersil Corporation and its products, see [www.intersil.com](http://www.intersil.com)