

# Inverting Micropower DC/DC Converter with Schottky in ThinSOT Package

## FEATURES

- Internal 40V Schottky Diode
- One Resistor Feedback (Other Resistor Inside)
- Internal 40V, 200mA Power Switch
- Generates Regulated Negative Outputs to  $-38V$
- Low Quiescent Current:
  - 40 $\mu A$  in Active Mode
  - <1 $\mu A$  in Shutdown Mode
- Low  $V_{CESAT}$  Switch: 200mV at 150mA
- Wide Input Range: 2.5V to 16V
- Uses Small Surface Mount Components
- Output Short-Circuit Protected
- Available in a 6-Lead SOT-23 Package

## APPLICATIONS

- LCD Bias
- Handheld Computers
- Battery Backup
- Digital Cameras
- OLED Bias

## DESCRIPTION

The LT<sup>®</sup>3483 is a micropower inverting DC/DC converter with integrated Schottky and one resistor feedback. The small package size, high level of integration and use of tiny surface mount components yield a solution size as small as 40mm<sup>2</sup>. The device features a quiescent current of only 40 $\mu A$  at no load, which further reduces to 0.1 $\mu A$  in shutdown. A current limited, fixed off-time control scheme conserves operating current, resulting in high efficiency over a broad range of load current. A precisely trimmed 10 $\mu A$  feedback current enables one resistor feedback and virtually eliminates feedback loading of the output. The 40V switch enables voltage outputs up to  $-38V$  to be generated without the use of costly transformers. The LT3483's low 300ns off-time permits the use of tiny low profile inductors and capacitors to minimize footprint and cost in space-conscious portable applications.

The LT3483 is available in the low profile (1mm) SOT-23 (ThinSOT<sup>™</sup>) package.

LT, LTC and LT are registered trademarks of Linear Technology Corporation. ThinSOT is a trademark of Linear Technology Corporation. Patent pending.

## TYPICAL APPLICATION

3.6V to  $-8V$  DC/DC Converter

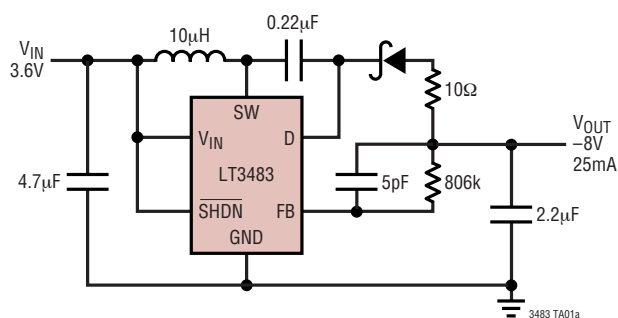

Efficiency and Power Loss

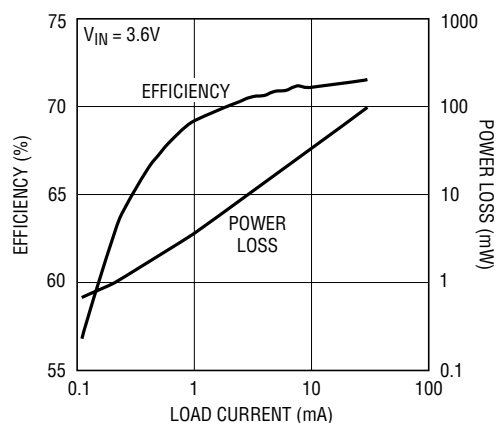

3483 TA01b

## ABSOLUTE MAXIMUM RATINGS

(Note 1)

$V_{IN}$ Voltage .....	16V
SW Voltage .....	40V
D Voltage .....	-40V
FB Voltage .....	2.5V
SHDN Voltage .....	16V
Operating Ambient Temperature Range (Note 2) .....	-40°C to 85°C
Junction Temperature .....	125°C
Storage Temperature Range .....	-65°C to 150°C
Lead Temperature (Soldering, 10 sec) .....	300°C

## PACKAGE/ORDER INFORMATION

	ORDER PART NUMBER
	LT3483ES6
	S6 PART MARKING
	LTBKX

Consult LTC Marketing for parts specified with wider operating temperature ranges.

## ELECTRICAL CHARACTERISTICS

The ● denotes specifications which apply over the full operating temperature range, otherwise specifications are  $T_A = 25^\circ\text{C}$ .

$V_{IN} = 3.6\text{V}$ ,  $V_{SHDN} = 3.6\text{V}$  unless otherwise specified.

PARAMETER	CONDITIONS	MIN	TYP	MAX	UNITS
$V_{IN}$ Operating Range		2.5		16	V
$V_{IN}$ Undervoltage Lockout			2	2.4	V
FB Comparator Trip Voltage to GND ( $V_{FB}$ )	FB Falling ●	0	5	12	mV
FB Output Current (Note 3)	FB = $V_{FB} - 5\text{mV}$ ●	-10.15	-10	-9.75	$\mu\text{A}$
FB Comparator Hysteresis	FB Rising		10		mV
Quiescent Current in Shutdown	$V_{SHDN} = \text{GND}$			1	$\mu\text{A}$
Quiescent Current (Not Switching)	FB = -0.05V		40	50	$\mu\text{A}$
$I_{FB}$ Line Regulation	$2.5\text{V} \leq V_{IN} \leq 16\text{V}$			0.07	%/V
Switch Off-Time			300		ns
Switch Current Limit		170	200	230	mA
Switch $V_{CESAT}$	$I_{SW} = 150\text{mA}$ to GND		200		mV
Switch Leakage Current	SW = 40V			1	$\mu\text{A}$
Rectifier Leakage Current	D = -40V			4	$\mu\text{A}$
Rectifier Forward Drop	$I_D = 150\text{mA}$ to GND		0.64		V
SHDN Input Low Voltage				0.4	V
SHDN Input High Voltage		1.5			V
SHDN Pin Current			6	10	$\mu\text{A}$

**Note 1:** Absolute Maximum Ratings are those values beyond which the life of a device may be impaired.

**Note 2:** The LTC3483E is guaranteed to meet specifications from 0°C to 70°C. Specifications over the -40°C to 85°C operating temperature range are assured by design, characterization and correlation with statistical process controls.

**Note 3:** Current flows out of the pin.

## TYPICAL PERFORMANCE CHARACTERISTICS

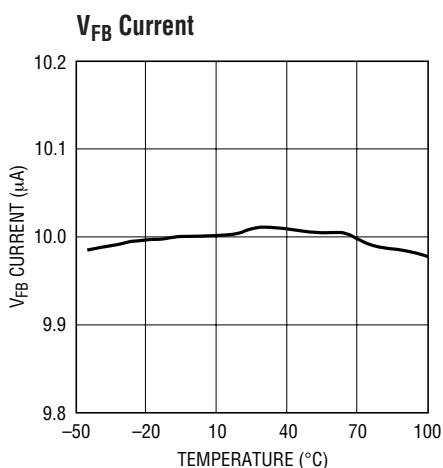

3483 G01

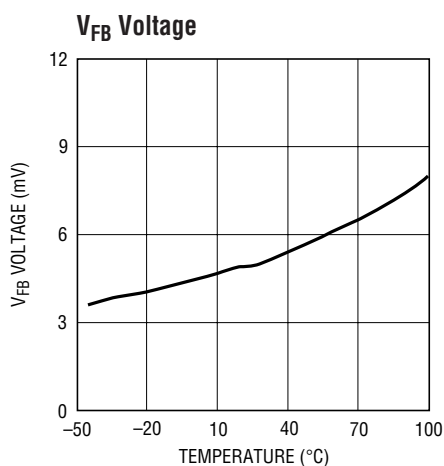

3483 G02

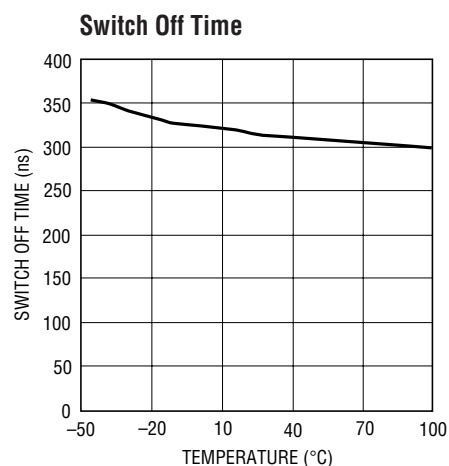

3483 G03

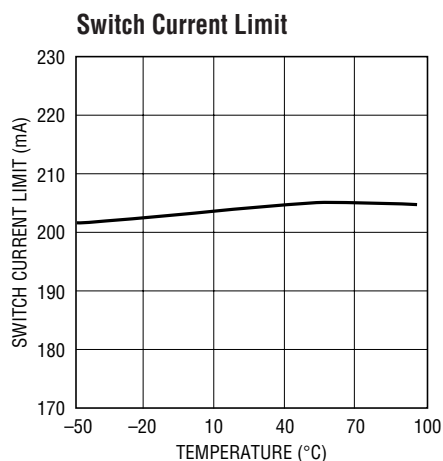

3483 G04

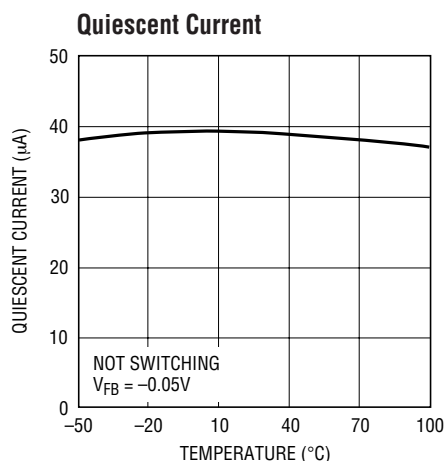

3483 G05

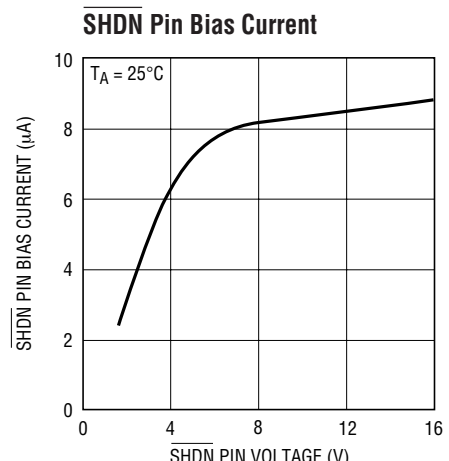

3483 G06

## PIN FUNCTIONS

**SW:** Switch. Connect to external inductor L1 and positive terminal of transfer capacitor.

**GND:** Ground.

**FB:** Feedback. Place resistor to negative output here. Set resistor value  $R1 = V_{OUT}/10\mu A$ .

**SHDN:** Shutdown. Connect to GND to turn device off. Connect to supply to turn device on.

**D:** Anode Terminal of Integrated Schottky Diode. Connect to negative terminal of transfer capacitor and external inductor L2 (flyback configuration) or to cathode of external Schottky diode (inverting charge pump configuration).

**V<sub>IN</sub>:** Input Supply. Must be locally bypassed with 1μF or greater.

**BLOCK DIAGRAM**

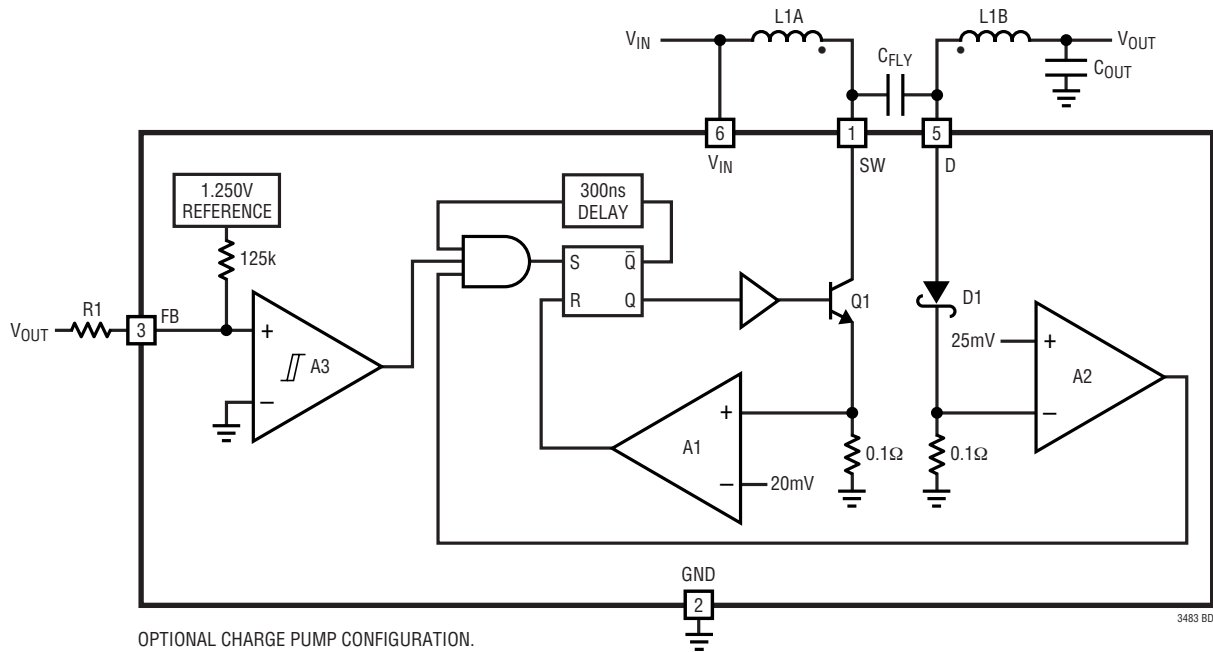

OPTIONAL CHARGE PUMP CONFIGURATION.  
L1B REPLACED WITH:



**OPERATION**

The LT3483 uses a constant off-time control scheme to provide high efficiency over a wide range of output currents. Operation can be best understood by referring to the Block Diagram. When the voltage at the FB pin is approximately 0V, comparator A3 disables most of the internal circuitry. Output current is then provided by external capacitor C<sub>OUT</sub>, which slowly discharges until the voltage at the FB pin goes above the hysteresis point of A3. Typical hysteresis at the FB pin is 10mV. A3 then enables the internal circuitry, turns on power switch Q1, and the currents in external inductors L1A and L1B begin to ramp up. Once the

switch current reaches 200mA, comparator A1 resets the latch, which turns off Q1 after about 80ns. Inductor current flows through the internal Schottky D1 to GND, charging the flying capacitor. Once the 300ns off-time has elapsed, and internal diode current drops below 250mA (as detected by comparator A2), Q1 turns on again and ramps up to 200mA. This switching action continues until the output capacitor charge is replenished (until the FB pin decreases to 0V), then A3 turns off the internal circuitry and the cycle repeats. The inverting charge pump topology replaces L1B with the series combination D2 and R2.

## APPLICATIONS INFORMATION

### CHOOSING A REGULATOR TOPOLOGY

#### Inverting Charge Pump

The inverting charge pump regulator combines an inductor-based step-up with an inverting charge pump. This configuration usually provides the best size, efficiency and output ripple and is applicable where the magnitude of  $V_{OUT}$  is greater than  $V_{IN}$ . Negative outputs to  $-38V$  can be produced with the LT3483 in this configuration. For cases where the magnitude of  $V_{OUT}$  is less than or equal to  $V_{IN}$ , use a 2-inductor or transformer configuration such as the inverting flyback.

In the inverting charge pump configuration, a resistor is added in series with the Schottky diode between the negative output and the D pin of the LT3483. The purpose of this resistor is to smooth/reduce the current spike in the flying capacitor when the switch turns on. A  $10\Omega$  resistor works well for a  $Li^+$  to  $-8V$  application, and the impact to converter efficiency is less than 3%. The resistor values recommended in the applications circuits also limit the switch current during a short-circuit condition at the output.

#### Inverting Flyback

The inverting flyback regulator, shown in the  $-5V$  application circuit, uses a coupled inductor and is an excellent choice where the magnitude of the output is less than or equal to the supply voltage. The inverting flyback also performs well in a step-up/invert application, but it occupies more board space compared with the inverting charge pump. Also, the maximum  $|V_{OUT}|$  using the flyback is less than can be obtained with the charge pump—it is reduced from  $38V$  by the magnitudes of  $V_{IN}$  and ringing at the switch node. Under a short-circuit condition at the output, a proprietary technique limits the switch current and prevents damage to the LT3483 even with supply voltage as high as  $16V$ . As an option, a  $0.47\mu F$  capacitor may be added between terminals D and SW of LT3483 to suppress ringing at SW.

#### Inductor Selection

Several recommended inductors that work well with the LT3483 are listed in Table 1, although there are many other manufacturers and devices that can be used. Consult each manufacturer for more detailed information and for their entire selection of related parts. Many different sizes and shapes are available. For inverting charge pump regulators with input and output voltages below  $7V$ , a  $4.7\mu H$  or  $6.8\mu H$  inductor is usually the best choice. For flyback regulators or for inverting charge pump regulators where the input or output voltage is greater than  $7V$ , a  $10\mu H$  inductor is usually the best choice. A larger value inductor can be used to slightly increase the available output current, but limit it to around twice the value recommended, as too large of an inductance will increase the output voltage ripple without providing much additional output current.

**Table 1. Recommended Inductors**

PART	L ( $\mu H$ )	MAX $I_{DC}$ (mA)	DCR ( $\Omega$ )	HEIGHT (mm)	MANUFACTURER
LQH2MCN4R7M02L	4.7	300	0.84	0.95	Murata www.murata.com
LQH2MCN6R8M02L	6.8	255	1.0		
LQH2MCN100M02L	10	225	1.2		
SDQ12	10	980	0.72	1.2	Cooper Electronics Tech www.cooperet.com
Coupled Inductor	15	780	1.15		
744876	10	550	0.46	1.2	Würth Elektronik www.we-online.com
Coupled Inductor					

#### Capacitor Selection

The small size and low ESR of ceramic capacitors make them ideal for LT3483 applications. Use of X5R and X7R types is recommended because they retain their capacitance over wider voltage and temperature ranges than other dielectric types. Always verify the proper voltage rating. Table 2 shows a list of several ceramic capacitor manufacturers. Consult the manufacturers for more detailed information on their entire selection of ceramic capacitors.

A  $4.7\mu F$  ceramic bypass capacitor on the  $V_{IN}$  pin is recommended where the distance to the power supply or battery could be more than a couple inches. Otherwise, a  $1\mu F$  is adequate.

## APPLICATIONS INFORMATION

A capacitor in parallel with feedback resistor R1 is recommended to reduce the output voltage ripple. Use a 5pF capacitor for the inverting charge pump, and a 22pF value for the inverting flyback or other dual inductor configurations. Output voltage ripple can be reduced to 20mV in some cases using this capacitor in combination with an appropriately selected output capacitor.

The output capacitor is selected based on desired output voltage ripple. For low output voltage ripple in the inverting flyback configuration, use a 4.7µF to 10µF capacitor. The inverting charge pump utilizes values ranging from 0.22µF to 4.7µF. The following formula is useful to estimate the output capacitor value needed:

$$C_{OUT} = \frac{L \cdot I_{SW}^2}{-V_{OUT} \cdot \Delta V_{OUT}}$$

where  $I_{SW} = 0.25A$  and  $\Delta V_{OUT} = 30mV$ . The flying capacitor in the inverting charge pump configuration ranges from 0.1µF to 0.47µF. Multiply the value predicted by the above equation for  $C_{OUT}$  by 1/10 to determine the value needed for the flying capacitor.

**Table 2. Recommended Ceramic Capacitor Manufacturers**

MANUFACTURER	URL
AVX	www.avxcorp.com
Kemet	www.kemet.com
Murata	www.murata.com
Taiyo Yuden	www.tyuden.com

### Setting the Output Voltage

The output voltage is programmed using one feedback resistor according to the following formula:

$$R1 = -\frac{V_{OUT}}{10\mu A}$$

### Inrush Current

When  $V_{IN}$  is increased from ground to operating voltage, an inrush current will flow through the input inductor and integrated Schottky diode to charge the flying capacitor.

Conditions that increase inrush current include a larger, more abrupt voltage step at  $V_{IN}$ , a larger flying capacitor, and an inductor with a low saturation current.

While the internal diode is designed to handle such events, the inrush current should not be allowed to exceed 1.5A. For circuits that use flying capacitors within the recommended range and have input voltages less than 5V, inrush current remains low, posing no hazard to the device. In cases where there are large steps at  $V_{IN}$ , inrush current should be measured to ensure operation within the limits of the device.

### Board Layout Considerations

As with all switching regulators, careful attention must be given to the PCB board layout and component placement. Proper layout of the high frequency switching path is essential. The voltage signals of the SW and D pins have sharp rising and falling edges. Minimize the length and area of all traces connected to the SW and D pins. In particular, it is desirable to minimize the trace length to and from the flying capacitor, since current in this capacitor switches directions within a cycle. Always use a ground plane under the switching regulator to minimize interplane coupling.

**Suggested Layout (SOT-23) for Inverting Charge Pump**

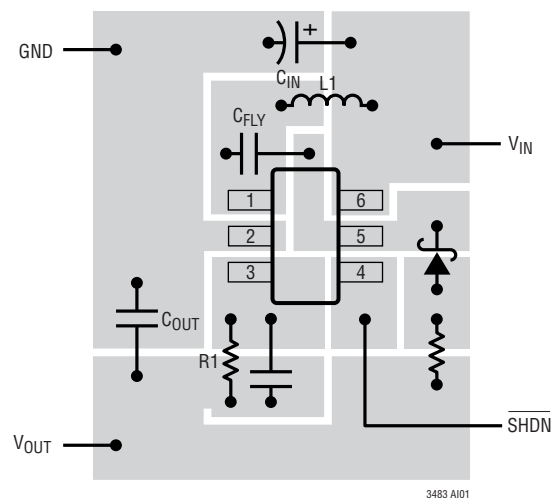

# TYPICAL APPLICATION

**3.6V to -8V DC/DC Converter**  
**Low Profile, Small Footprint**

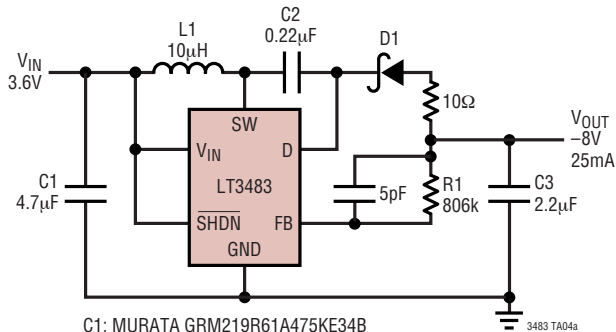

- C1: MURATA GRM219R61A475KE34B
- C2: TAIYO YUDEN LMK107BJ224
- C3: MURATA GRM219R61C225KA88B
- D1: PHILIPS PMEG2005EB
- L1: MURATA LQH2MCM100K02L

Switching Waveform

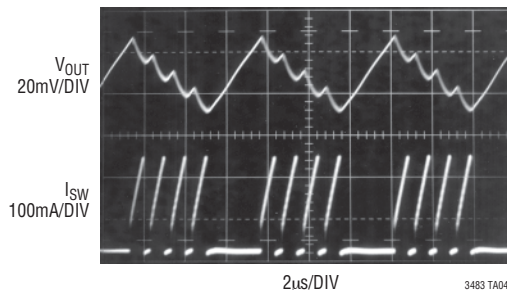

# PACKAGE DESCRIPTION

**S6 Package**  
**6-Lead Plastic TSOT-23**  
 (Reference LTC DWG # 05-08-1636)

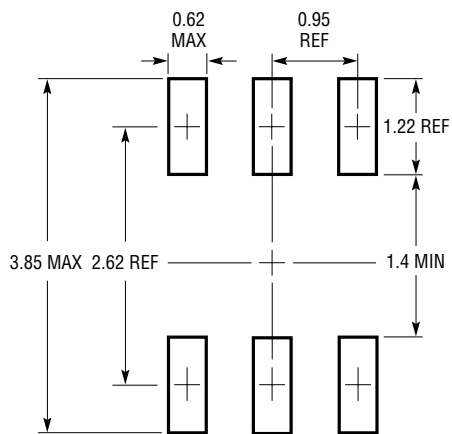

RECOMMENDED SOLDER PAD LAYOUT  
 PER IPC CALCULATOR

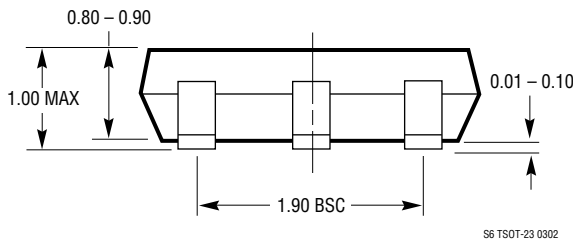
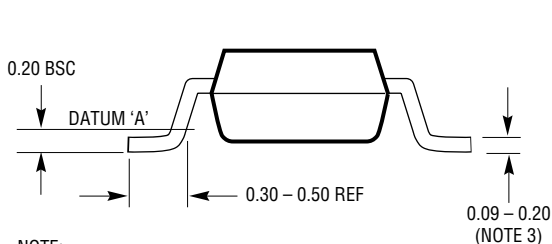
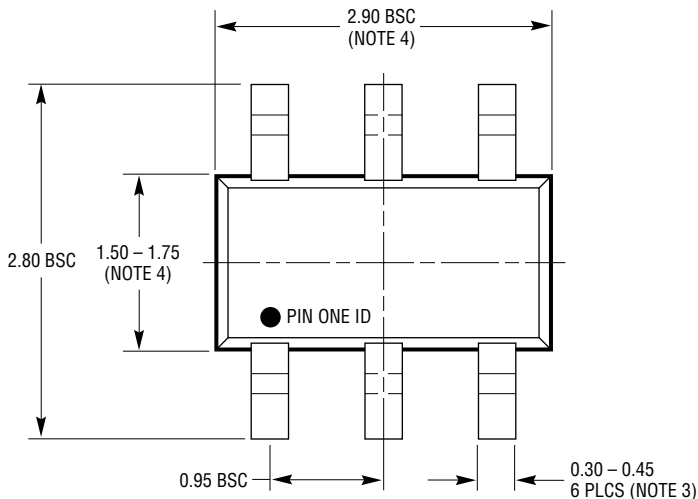

- NOTE:
1. DIMENSIONS ARE IN MILLIMETERS
  2. DRAWING NOT TO SCALE
  3. DIMENSIONS ARE INCLUSIVE OF PLATING

4. DIMENSIONS ARE EXCLUSIVE OF MOLD FLASH AND METAL BURR
5. MOLD FLASH SHALL NOT EXCEED 0.254mm
6. JEDEC PACKAGE REFERENCE IS MO-193

S6 TSOT-23 0302



TYPICAL APPLICATIONS

3.6V to -22V DC/DC Converter

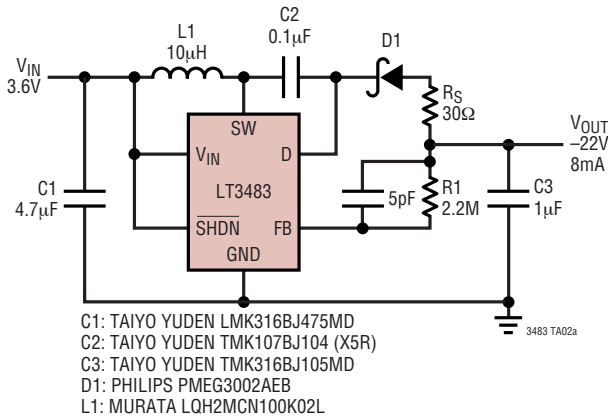

3.6V to -22V Converter Efficiency and Power Loss

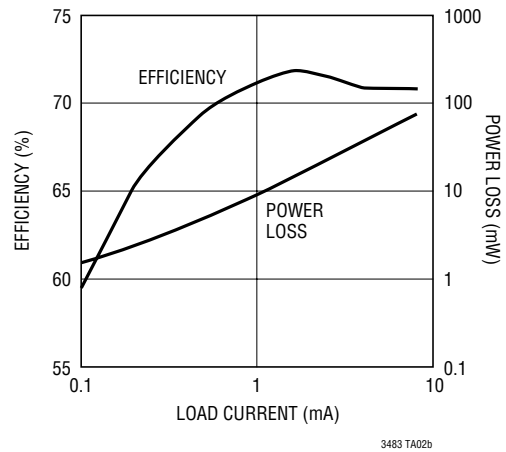

-5V DC/DC Converter

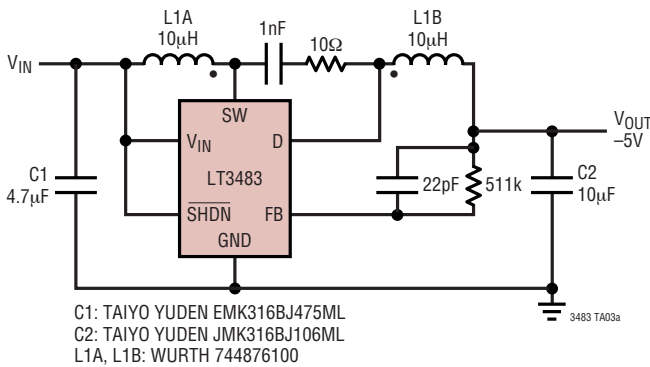

-5V Efficiency

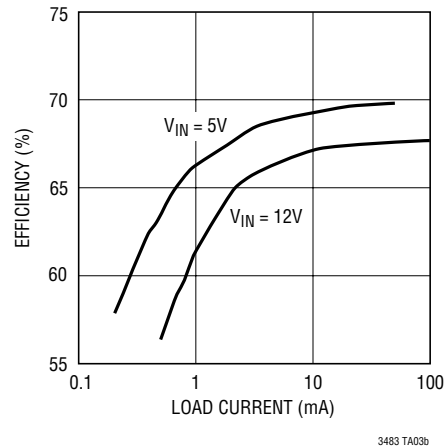

RELATED PARTS

PART NUMBER	DESCRIPTION	COMMENTS
LT1617/LT1617-1	350mA/100mA ( $I_{SW}$ ) High Efficiency Micropower Inverting DC/DC Converter	$V_{IN}$ : 1.2V to 15V, $V_{OUT(MAX)}$ = -34V, $I_Q$ = 20µA, $I_{SD}$ < 1µA ThinSOT Package
LT1931/LT1931A	1A ( $I_{SW}$ ), 1.2MHz/2.2MHz, High Efficiency Micropower Inverting DC/DC Converter	$V_{IN}$ : 2.6V to 16V, $V_{OUT(MAX)}$ = -34V, $I_Q$ = 5.8mA, $I_{SD}$ < 1µA ThinSOT Package
LT1945	Dual Output, Boost/Inverter, 350mA ( $I_{SW}$ ), Constant Off-Time, High Efficiency Step-Up DC/DC Converter	$V_{IN}$ : 1.2V to 15V, $V_{OUT(MAX)}$ = ±34V, $I_Q$ = 40µA, $I_{SD}$ < 1µA, MS10 Package
LT3463	Dual Output, Boost/Inverter, 250mA ( $I_{SW}$ ), Constant Off-Time, High Efficiency Step-Up DC/DC Converter with Integrated Schottky Diodes	$V_{IN}$ : 2.3V to 15V, $V_{OUT(MAX)}$ = ±40V, $I_Q$ = 40µA, $I_{SD}$ < 1µA DFN Package
LT3464	85mA ( $I_{SW}$ ), High Efficiency Step-Up DC/DC Converter with Integrated Schottky and PNP Disconnect	$V_{IN}$ : 2.3V to 10V, $V_{OUT(MAX)}$ = 34V, $I_Q$ = 25µA, $I_{SD}$ < 1µA ThinSOT Package
LT3472	Boost (350mA) and Inverting (400mA) DC/DC Converter for CCD Bias with Integrated Schottkys	$V_{IN}$ : 2.3V to 15V, $V_{OUT(MAX)}$ = ±40V, $I_Q$ = 2.8mA, $I_{SD}$ < 1µA DFN Package