

Features and Benefits

- n Chopper stabilized amplifier stage
- n Optimized for BDC motor applications
- n New miniature package / thin, high reliability package
- n Operation down to 3.5V
- n CMOS for optimum stability, quality and cost

Applications

- n Solid state switch
- n Brushless DC motor commutation
- n Speed sensing
- n Linear position sensing
- n Angular position sensing
- n Current sensing

Ordering Information

Part No.	Temperature Suffix	Package
US1881	E (-40°C to 85°C)	SO (SOT-23) or UA (TO-92 flat)
US1881	L (-40°C to 150°C)	SO (SOT-23) or UA (TO-92 flat)

*Contact factory or sales representative for legacy temperature options

Functional Diagram

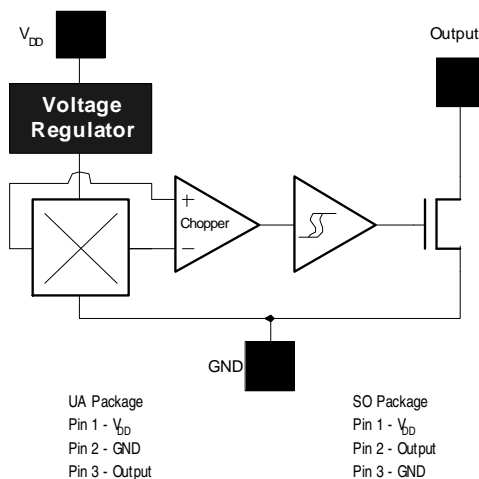

Description

The US1881 is the industry's first Hall integrated circuit in a SOT-23 package. The US1881 is a bipolar Hall effect sensor IC fabricated from mixed signal CMOS technology. It incorporates advanced chopper stabilization techniques to provide accurate and stable magnetic switch points. There are many applications for this HED in addition to those listed above. The design, specifications and performance have been optimized for commutation applications in 5V and 12V brushless DC motors.

The output transistor will be latched on (B_{OP}) in the presence of a sufficiently strong South pole magnetic field facing the marked side of the package. Similarly, the output will be latched off (B_{RP}) in the presence of a North field.

The SOT-23 device is reversed from the UA package. The SOT-23 output transistor will be latched on in the presence of a sufficiently strong North pole magnetic field applied to the marked face.

Note: Static sensitive device; please observe ESD precautions. Reverse V_{DD} protection is not included. For reverse voltage protection, a 100W resistor in series with V_{DD} is recommended.

US1881 Electrical Specifications

DC Operating Parameters: $T_A = 25$, $V_{DD} = 12V_{DC}$ (unless otherwise specified).

Parameter	Symbol	Test Conditions	Min	Typ	Max	Units
Supply Voltage	V_{DD}	Operating	3.5		24	V
Supply Current	I_{DD}	$B < B_{OP}$	1.1	2.5	5.0	mA
Saturation Voltage	$V_{DS(on)}$	$I_{OUT} = 20\text{ mA}$, $B > B_{OP}$		0.4	0.5	V
Output Leakage	I_{OFF}	$B < B_{RP}$, $V_{OUT} = 24V$		0.01	10.0	μA
Output Rise Time	t_r	$V_{DD} = 12V$, $R_L = 1.1K\Omega$, $C_L = 20pf$		0.04		μs
Output Fall Time	t_f	$V_{DD} = 12V$, $R_L = 1.1K\Omega$, $C_L = 20pf$		0.18		μs

US1881 Magnetic Specifications

Parameter	Symbol	Test Conditions	Min	Typ	Max	Units
Operating Point	B_{OP}	EUA, ESO, LUA, LSO 25°C, $V_{dd} = 3.5$ & 24 volts DC	1.0	5.0	9.0	mT
Release Point	B_{RP}	EUA, ESO, LUA, LSO 25°C, $V_{dd} = 3.5$ & 24 volts DC	-9.0	-5.0	-1.0	mT
Hysteresis	B_{hys}	EUA, ESO, LUA, LSO 25°C, $V_{dd} = 3.5$ & 24 volts DC	7.0	10.0	12.0	mT
Operating Point	B_{OP}	EUA, ESO 85°C, $V_{dd} = 3.5$ & 24 volts DC	0.5	5.0	9.5	mT
Release Point	B_{RP}	EUA, ESO 85°C, $V_{dd} = 3.5$ & 24 volts DC	-9.5	-5.0	-0.5	mT
Hysteresis	B_{hys}	EUA, ESO 85°C, $V_{dd} = 3.5$ & 24 volts DC	7.0	10.0	12.0	mT
Operating Point	B_{OP}	LUA, LSO 150°C, $V_{dd} = 3.5$ & 24 volts DC	0.5	5.0	9.5	mT
Release Point	B_{RP}	LUA, LSO 150°C, $V_{dd} = 3.5$ & 24 volts DC	-9.5	-5.0	-0.5	mT
Hysteresis	B_{hys}	LUA, LSO 150°C, $V_{dd} = 3.5$ & 24 volts DC	6.0	10.0	12.5	mT

Performance Graphs

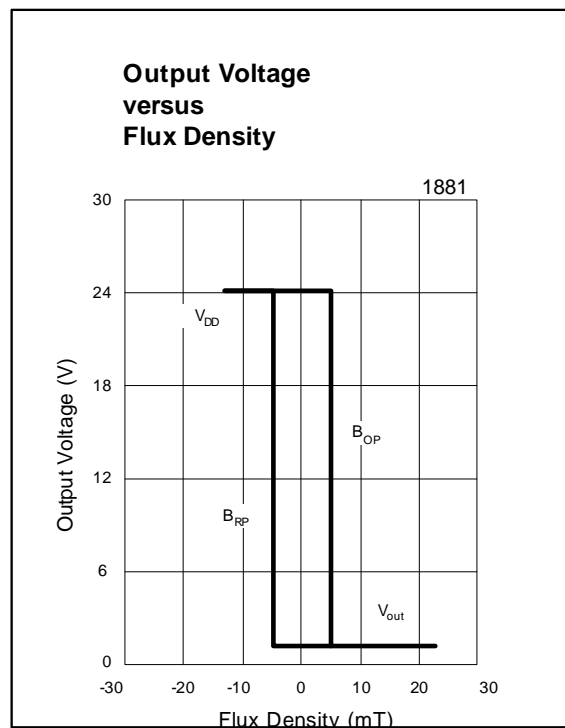
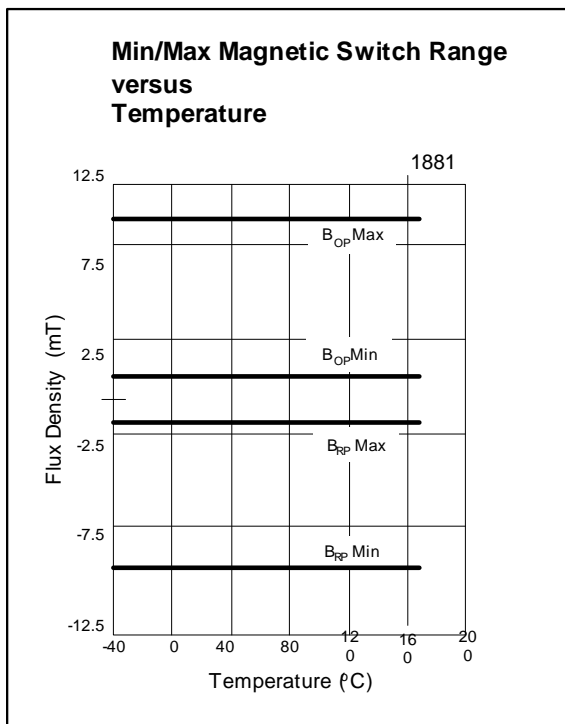
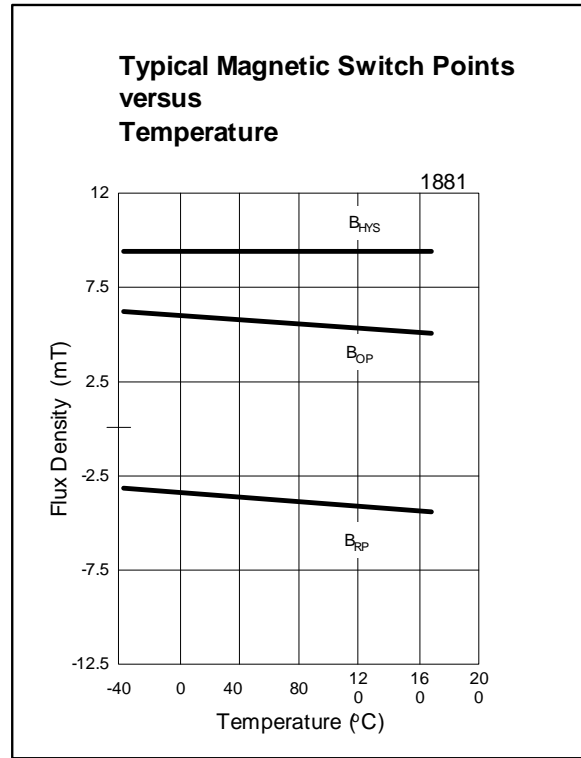
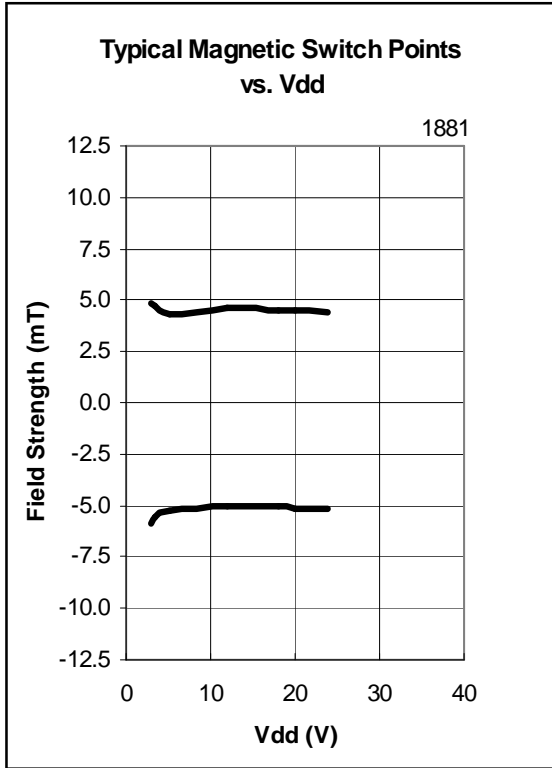

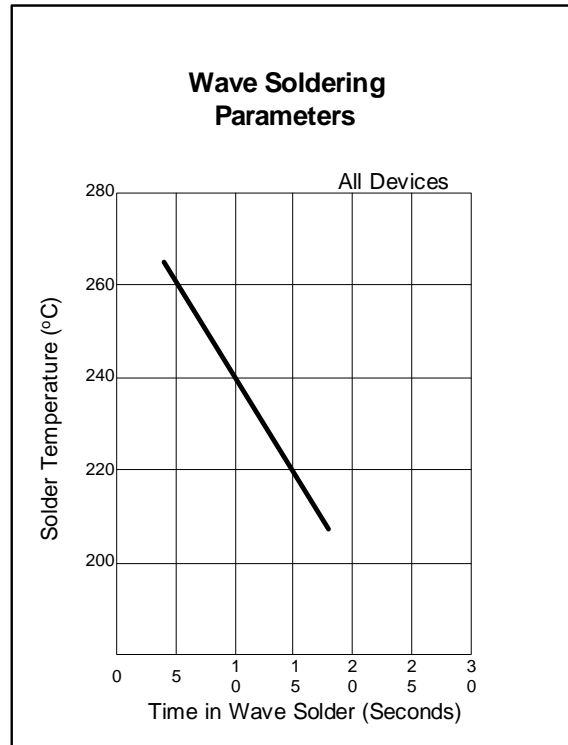
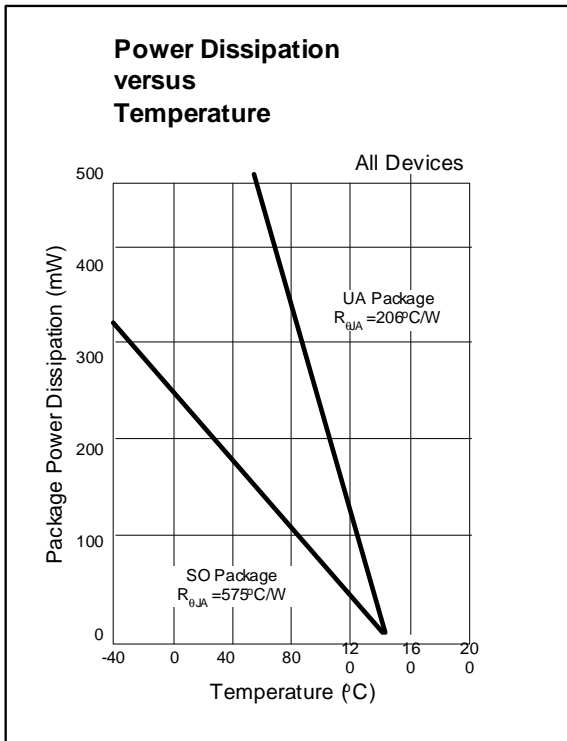

Absolute Maximum Ratings

Supply Voltage (Operating), V_{DD}	3.5V to 24V
Supply Current (Fault), I_{DD}	50mA
Output Voltage, V_{OUT}	3.5V to 24V
Output Current (Fault), I_{OUT}	50mA
Power Dissipation, P_D	100mW
Operating Temperature Range, T_A	-40 to 150°C
Storage Temperature Range, T_S	-65°C to 150°C
Maximum Junction Temp, T_J	175°C

Performance Graphs

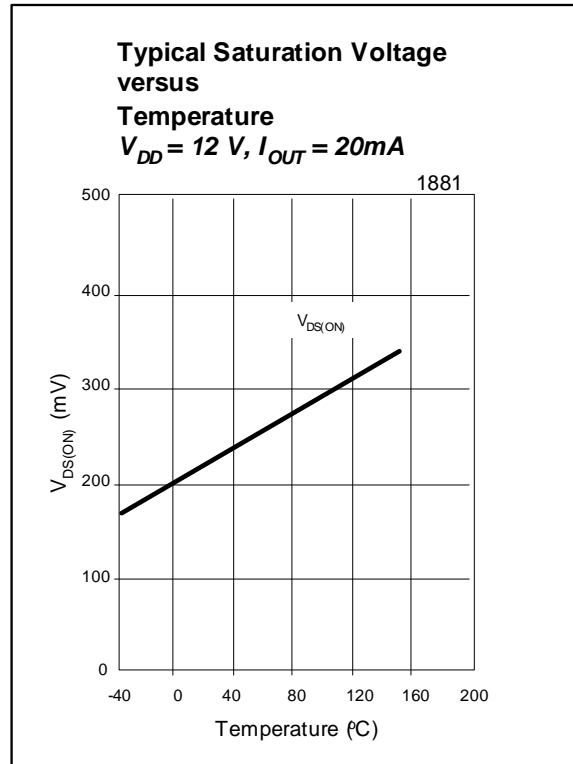
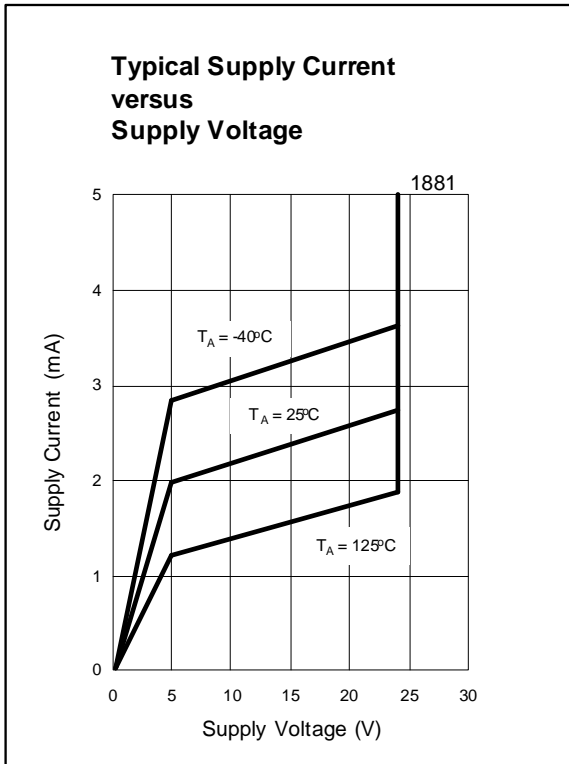

Unique Features

CMOS Hall IC Technology

The chopper stabilized amplifier uses switched capacitor techniques to eliminate the amplifier offset voltage, which, in bipolar devices, is a major source of temperature-sensitive drift. CMOS makes this advanced technique possible. The CMOS chip is also much smaller than a bipolar chip, allowing very sophisticated circuitry to be placed in less space. The small chip size also contributes to lower physical stress and less power consumption.

Installation

Consider Temperature Coefficients of Hall IC and magnetics, as well as air gap and life time variations. Observe ESD control procedures. Observe temperature limits during wave soldering.

Applications

If reverse supply protection is desired, use a resistor in series with the V_{DD} pin that will limit the Supply Current (Fault), I_{DD} , to 50 mA. For severe

EMC conditions, use the application circuit on the following page.

Applications Examples

Automotive and Severe Environment Protection Circuit

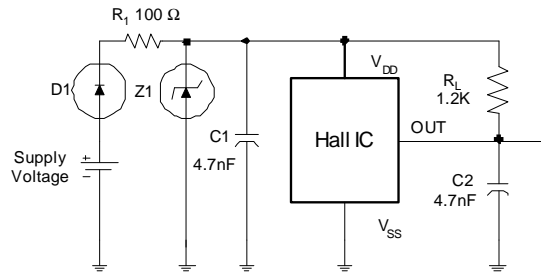

Two Wire Optional Current Biasing Circuit

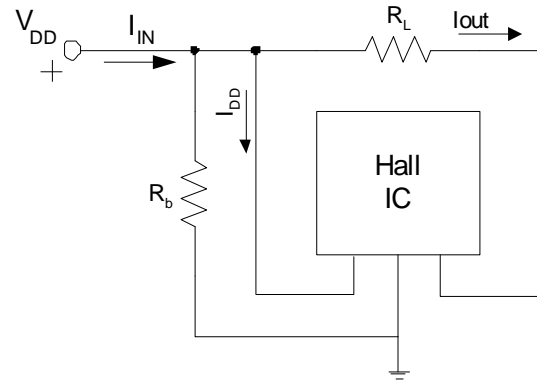

The resistors R_b and R_L can be used to bias the input current, I_{in} . Refer to the part specification for limiting values. This circuit will help in getting the precise ON and OFF currents desired.

$$B_{OP} = I_{off} = (V_{DD} / R_b + I_{DD})$$

$$B_{ON} = I_{on} = (I_{off} + V_{DD} / R_L)$$

Physical Characteristics

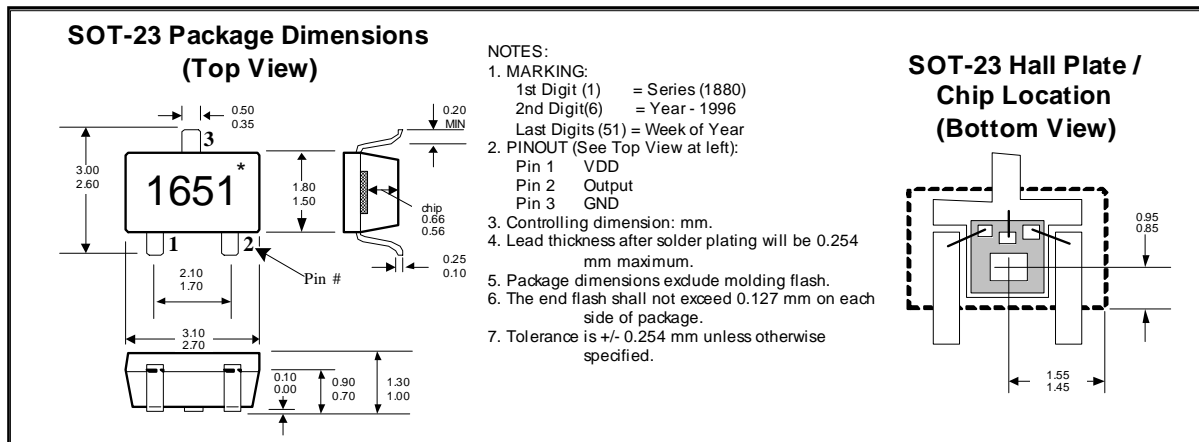
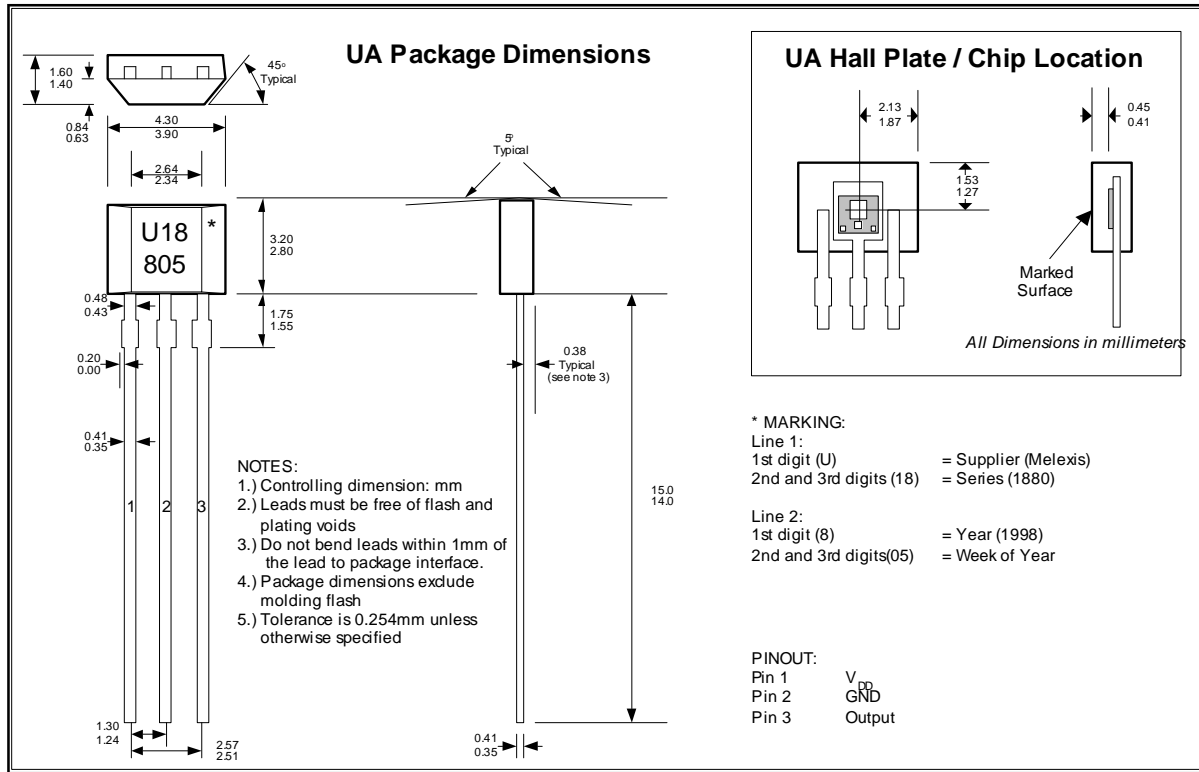

Reliability Information

Melexis devices are classified and qualified regarding suitability for infrared, vapor phase and wave soldering with usual (63/37 SnPb-) solder (melting point at 183degC).

The following test methods are applied:

IPC/JEDEC J-STD-020A (issue April 1999)

Moisture/Reflow Sensitivity Classification For Nonhermetic Solid State Surface Mount Devices

CECC00802 (issue 1994)

Standard Method For The Specification of Surface Mounting Components (SMDs) of Assessed Quality

MIL 883 Method 2003 / JEDEC-STD-22 Test Method B102

Solderability

For all soldering technologies deviating from above mentioned standard conditions (regarding peak temperature, temperature gradient, temperature profile etc) additional classification and qualification tests have to be agreed upon with Melexis.

The application of Wave Soldering for SMD's is allowed only after consulting Melexis regarding assurance of adhesive strength between device and board.

For more information on manufacturability/solderability see quality page at our website:
<http://www.melexis.com/>

ESD Precautions

Electronic semiconductor products are sensitive to Electro Static Discharge (ESD).

Always observe Electro Static Discharge control procedures whenever handling semiconductor products.

Disclaimer

Devices sold by Melexis are covered by the warranty and patent indemnification provisions appearing in its Term of Sale. Melexis makes no warranty, express, statutory, implied, or by description regarding the information set forth herein or regarding the freedom of the described devices from patent infringement. Melexis reserves the right to change specifications and prices at any time and without notice. Therefore, prior to designing this product into a system, it is necessary to check with Melexis for current information. This product is intended for use in normal commercial applications. Applications requiring extended temperature range, unusual environmental requirements, or high reliability applications, such as military, medical life-support or life-sustaining equipment are specifically not recommended without additional processing by Melexis for each application.

The information furnished by Melexis is believed to be correct and accurate. However, Melexis shall not be liable to recipient or any third party for any damages, including but not limited to personal injury, property damage, loss of profits, loss of use, interrupt of business or indirect, special incidental or consequential damages, of any kind, in connection with or arising out of the furnishing, performance or use of the technical data herein. No obligation or liability to recipient or any third party shall arise or flow out of Melexis' rendering of technical or other services.

© 2002 Melexis NV. All rights reserved.

For the latest version of this document, go to our website at:

www.melexis.com

Or for additional information contact Melexis Direct:

Europe and Japan:

Phone: +32 13 67 04 95
E-mail: sales_europe@melexis.com

All other locations:

Phone: +1 603 223 2362
E-mail: sales_usa@melexis.com

QS9000, VDA6.1 and ISO14001 Certified