

18Mb QDR™ SRAM 2-WORD BURST

**MT54V1MH18A
MT54V512H36A**

Features

- Separate independent read and write data ports with concurrent transactions
- 100 percent bus utilization DDR READ and WRITE operation
- High frequency operation with future migration to higher clock frequencies
- Fast clock to valid data times
- Full data coherency, providing most current data
- Two-tick burst counter for low DDR transaction size
- Double data rate operation on read and write ports
- Two input clocks (K and K#) for precise DDR timing at clock rising edges only
- Two output clocks (C and C#) for precise flight time and clock skew matching—clock and data delivered together to receiving device
- Optional-use echo clocks (CQ and CQ#) for flexible receive data synchronization
- Single address bus
- Simple control logic for easy depth expansion
- Internally self-timed, registered writes
- 2.5V core and 1.5 to 1.8V (±0.1V) HSTL I/O
- Clock-stop capability
- 13mm x 15mm, 1mm pitch, 11 x 15 grid FBGA package
- User-programmable impedance output
- JTAG boundary scan

Options

| | Marking ¹ |
|---|----------------------|
| • Clock Cycle Timing | |
| 6ns (167 MHz) | -6 |
| 7.5ns (133 MHz) | -7.5 |
| 10ns (100 MHz) | -10 |
| • Configurations | |
| 1 Meg x 18 | MT54V1MH18A |
| 512K x 36 | MT54V512H36A |
| • Package | |
| 165-ball, 13mm x 15mm FBGA | F |
| • Operating Temperature Range | |
| Commercial (0°C ≤ T _A ≤ +70°C) | None |

NOTE:

1. A Part Marking Guide for the FBGA devices can be found on Micron's Web site—<http://www.micron.com/numberguide>.

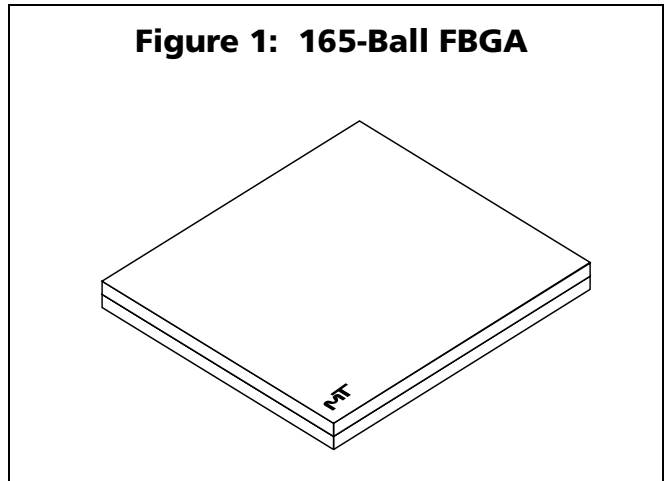

Table 1: Valid Part Numbers

| PART NUMBER | DESCRIPTION |
|------------------|------------------------|
| MT54V1MH18AF-xx | 1 Meg x 18, QDRb2 FBGA |
| MT54V512H36AF-xx | 512K x 36, QDRb2 FBGA |

General Description

The Micron® QDR™ (Quad Data Rate™) synchronous, pipelined burst SRAM employs high-speed, low-power CMOS designs using an advanced 6T CMOS process.

The QDR architecture consists of two separate DDR (double data rate) ports to access the memory array. The read port has dedicated data outputs to support READ operations. The write port has dedicated data inputs to support WRITE operations. This architecture eliminates the need for high-speed bus turnaround. Access to each port is accomplished using a common address bus. Addresses for reads and writes are latched on rising edges of the K and K# input clocks, respectively. Each address location is associated with two words that burst sequentially into or out of the device. Since data can be transferred into and out of the device on every rising edge of both clocks (K and K# and C and C#), memory bandwidth is maximized and system design is simplified by eliminating bus turnarounds.

Depth expansion is accomplished with port selects for each port (read R#, write W#) which are received at K rising edge. Port selects permit independent port operation.

All synchronous inputs pass through registers controlled by the K or K# input clock rising edges. Active LOW byte writes (BWx#) permit byte or nibble write selection. Write data and byte writes are registered on the rising edges of both K and K#. The addressing within each burst of two is fixed and sequential, beginning with the lowest and ending with the highest address. All synchronous data outputs pass through output registers controlled by the rising edges of the output clocks (C and C# if provided, otherwise K and K#).

Four balls are used to implement JTAG test capabilities: test mode select (TMS), test data-in (TDI), test clock (TCK), and test data-out (TDO). JTAG circuitry is used to serially shift data to and from the SRAM. JTAG inputs use JEDEC-standard 2.5V I/O levels to shift data during this testing mode of operation.

The SRAM operates from a 2.5V power supply, and all inputs and outputs are HSTL-compatible. The device is ideally suited for applications that benefit from a high-speed, fully-utilized DDR data bus.

Please refer to Micron's Web site (www.micron.com/sramds) for the latest data sheet.

READ/WRITE Operations

All bus transactions operate on an uninterruptable burst of two data, requiring one full clock cycle of bus utilization. The resulting benefit is that short data transactions can remain in operation on both buses provided that the address rate can be maintained by the system (2x the clock frequency).

READ cycles are pipelined. The request is initiated by asserting R# LOW at K rising edge. Data is delivered after the next rising edge of the next K, using C and C# as the output timing references; or K and K#, if C and C# are tied HIGH. If C and C# are tied HIGH, they may not be toggled during device operation. Output tri-stating is automatically controlled such that the bus is released if no data is being delivered. This permits banked SRAM systems with no complex output enable (OE) timing generation. Back-to-back READ cycles are initiated every K rising edge.

WRITE cycles are initiated by W# LOW at K rising edge. The addresses for the WRITE cycle is provided at the following K# rising edge. Data is expected at the rising edge of K and K#, beginning at the same K that initiated the cycle. Write registers are incorporated to facilitate pipelined, self-timed WRITE cycles and provide fully coherent data for all combinations of reads and writes. A read can immediately follow a write, even if they are to the same address. Although the write data has not been written to the memory array, the SRAM will deliver the data from the write register instead of using the older data from the memory array. The latest data is always utilized for all bus transactions. WRITE cycles can be initiated on every K rising edge.

BYTE WRITE Operations

BYTE WRITE operations are supported. The active LOW byte write controls are registered coincident with their corresponding data. This feature can eliminate the need for some READ-MODIFY-WRITE cycles, collapsing it to a single BYTE WRITE operation in some instances.

Programmable Impedance Output Buffer

The QDR SRAM is equipped with programmable impedance output buffers. This allows a user to match the driver impedance to the system. To adjust the impedance, an external precision resistor (RQ) is connected between the ZQ ball and V_{SS}. The value of the resistor must be five times the desired impedance. For example, a 350Ω resistor is required for an output impedance of 70Ω. To ensure that output impedance is one-fifth the value of RQ (within 15 percent), the range of RQ is 175Ω to 350Ω. Alternately, the ZQ ball can be connected directly to V_{DDQ}, which will place the device in a minimum impedance mode.

Output impedance updates may be required because variations may occur in supply voltage and temperature over time. The device samples the value of RQ. Impedance updates are transparent to the system; they do not affect device operation, and all data sheet timing and current specifications are met during an update.

The device will power up with an output impedance set at 50Ω. To guarantee optimum output driver impedance after power-up, the SRAM needs 1,024 cycles to update the impedance. The user can operate the part with fewer than 1,024 clock cycles, but optimal output impedance is not guaranteed.

Clock Considerations

This device does not utilize internal phase-locked loops and can therefore be placed into a stopped-clock state to minimize power without lengthy restart times.

It is strongly recommended that the clocks operate for a number of cycles prior to initiating commands to the SRAM. This delay permits transmission line charging effects to be overcome and allows the clock timing to be nearer to its steady-state value.

Single Clock Mode

The SRAM can be used with the single K, K# clock pair by tying C and C# HIGH. In this mode the SRAM will use K and K# in place of C and C#. This mode provides the most rapid data output but does not compensate for system clock skew and flight times.

The output echo clocks are precise references to output data. CQ and CQ# are both rising edge and falling edge accurate and are 180° out of phase. Either or both may be used for output data capture. K or C rising edge triggers CQ rising and CQ# falling edge. CQ rising edge indicates first data response for QDRI and DDRI (version 1, non-DLL) SRAM, while CQ# rising edge indicates first data response for QDRII and DDRII (version 2, DLL) SRAM.

Depth Expansion

Port select inputs are provided for the read and write ports. This allows for easy depth expansion. Both port selects are sampled on the rising edge of K only. Each port can be independently selected and deselected and does not affect the operation of the opposite port. All pending transactions are completed prior to a port deselecting.

Figure 2: Functional Block Diagram
1 Meg x 18; 512K x 36

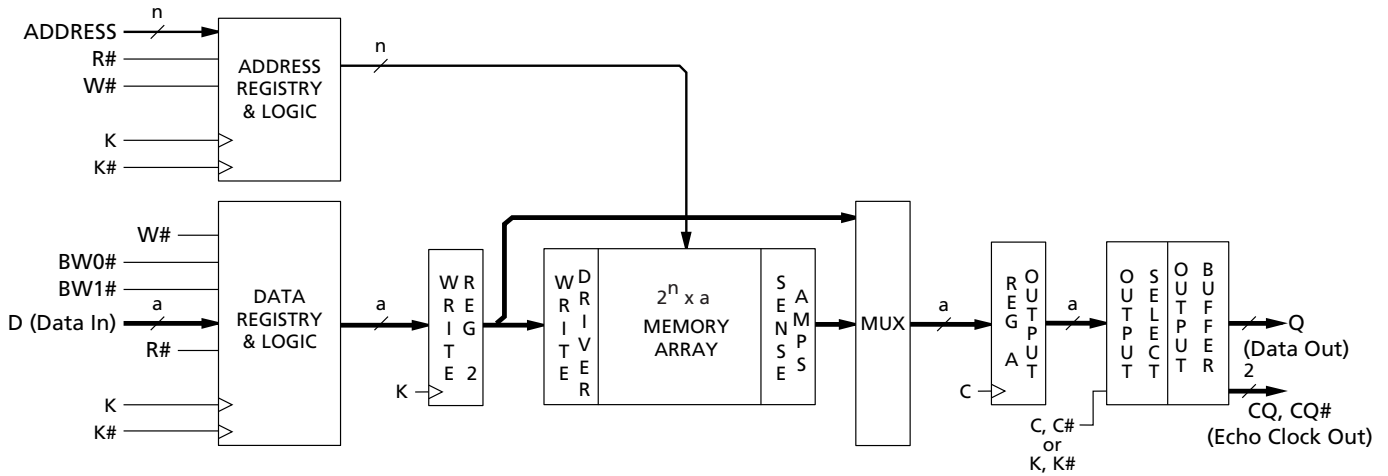

NOTE:

1. Figure 2 illustrates simplified device operation. See truth table, ball descriptions, and timing diagrams for detailed information.
2. For 1 Meg x 18, n = 18, a = 18.
3. For 512K x 36, n = 18, a = 36.

Figure 3: Application Example

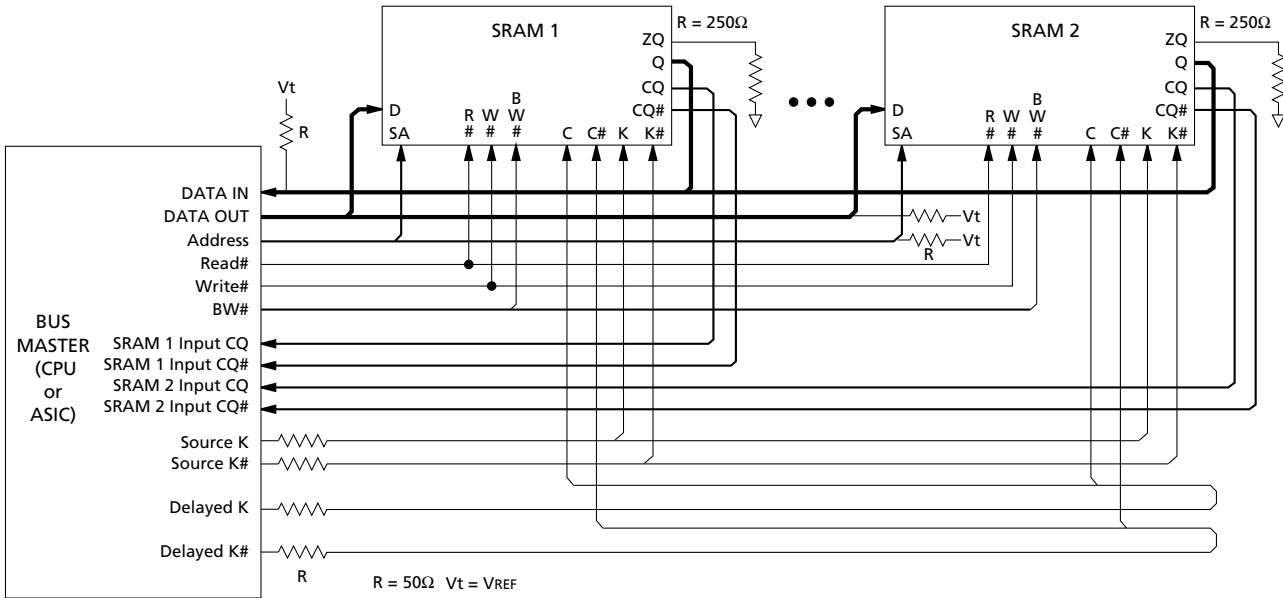

NOTE:

1. Consult Micron Technical Notes for more thorough discussions of clocking schemes.
2. Data capture is possible using only one of the two signals. CQ and CQ# clocks are optional use outputs.
3. For high frequency applications (200 MHz and faster) the CQ and CQ# clocks (for data capture) are recommended over the C and C# clocks (for data alignment). The C and C# clocks are optional use inputs.

Table 2: 1 Meg x 18 Ball Layout (Top View)
165-Ball FBGA

| | 1 | 2 | 3 | 4 | 5 | 6 | 7 | 8 | 9 | 10 | 11 |
|----------|-----|------------------|--------------------|------------------|-----------------|-----------------|-----------------|------------------|------------------|------------------|-----|
| A | CQ# | V _{SS} | NC/SA ¹ | W# | BW1# | K# | NC | R# | SA | V _{SS} | CQ |
| B | NC | Q9 | D9 | SA | NC | K | BW0# | SA | NC | NC | Q8 |
| C | NC | NC | D10 | V _{SS} | SA | SA | SA | V _{SS} | NC | Q7 | D8 |
| D | NC | D11 | Q10 | V _{SS} | V _{SS} | V _{SS} | V _{SS} | V _{SS} | NC | NC | D7 |
| E | NC | NC | Q11 | V _{DDQ} | V _{SS} | V _{SS} | V _{SS} | V _{DDQ} | NC | D6 | Q6 |
| F | NC | Q12 | D12 | V _{DDQ} | V _{DD} | V _{SS} | V _{DD} | V _{DDQ} | NC | NC | Q5 |
| G | NC | D13 | Q13 | V _{DDQ} | V _{DD} | V _{SS} | V _{DD} | V _{DDQ} | NC | NC | D5 |
| H | NC | V _{REF} | V _{DDQ} | V _{DDQ} | V _{DD} | V _{SS} | V _{DD} | V _{DDQ} | V _{DDQ} | V _{REF} | ZQ |
| J | NC | NC | D14 | V _{DDQ} | V _{DD} | V _{SS} | V _{DD} | V _{DDQ} | NC | Q4 | D4 |
| K | NC | NC | Q14 | V _{DDQ} | V _{DD} | V _{SS} | V _{DD} | V _{DDQ} | NC | D3 | Q3 |
| L | NC | Q15 | D15 | V _{DDQ} | V _{SS} | V _{SS} | V _{SS} | V _{DDQ} | NC | NC | Q2 |
| M | NC | NC | D16 | V _{SS} | V _{SS} | V _{SS} | V _{SS} | V _{SS} | NC | Q1 | D2 |
| N | NC | D17 | Q16 | V _{SS} | SA | SA | SA | V _{SS} | NC | NC | D1 |
| P | NC | NC | Q17 | SA | SA | C | SA | SA | NC | D0 | Q0 |
| R | TDO | TCK | SA | SA | SA | C# | SA | SA | SA | TMS | TDI |

NOTE:

- Expansion address: 3A for 36Mb

**Table 3: 512K x 36 Ball Layout (Top View)
165-Ball FBGA**

| | 1 | 2 | 3 | 4 | 5 | 6 | 7 | 8 | 9 | 10 | 11 |
|----------|-----|------------------|------------------|------------------|-------------------|-----------------|-------------------|------------------|----------------------------------|------------------|-----|
| A | CQ# | V _{SS} | NC | W# | BW2# ¹ | K# | BW1# ² | R# | V _{SS} /SA ³ | V _{SS} | CQ |
| B | Q27 | Q18 | D18 | SA | BW3# ⁴ | K | BW0# ⁵ | SA | D17 | Q17 | Q8 |
| C | D27 | Q28 | D19 | V _{SS} | SA | SA | SA | V _{SS} | D16 | Q7 | D8 |
| D | D28 | D20 | Q19 | V _{SS} | V _{SS} | V _{SS} | V _{SS} | V _{SS} | Q16 | D15 | D7 |
| E | Q29 | D29 | Q20 | V _{DDQ} | V _{SS} | V _{SS} | V _{SS} | V _{DDQ} | Q15 | D6 | Q6 |
| F | Q30 | Q21 | D21 | V _{DDQ} | V _{DD} | V _{SS} | V _{DD} | V _{DDQ} | D14 | Q14 | Q5 |
| G | D30 | D22 | Q22 | V _{DDQ} | V _{DD} | V _{SS} | V _{DD} | V _{DDQ} | Q13 | D13 | D5 |
| H | NC | V _{REF} | V _{DDQ} | V _{DDQ} | V _{DD} | V _{SS} | V _{DD} | V _{DDQ} | V _{DDQ} | V _{REF} | ZQ |
| J | D31 | Q31 | D23 | V _{DDQ} | V _{DD} | V _{SS} | V _{DD} | V _{DDQ} | D12 | Q4 | D4 |
| K | Q32 | D32 | Q23 | V _{DDQ} | V _{DD} | V _{SS} | V _{DD} | V _{DDQ} | Q12 | D3 | Q3 |
| L | Q33 | Q24 | D24 | V _{DDQ} | V _{SS} | V _{SS} | V _{SS} | V _{DDQ} | D11 | Q11 | Q2 |
| M | D33 | Q34 | D25 | V _{SS} | V _{SS} | V _{SS} | V _{SS} | V _{SS} | D10 | Q1 | D2 |
| N | D34 | D26 | Q25 | V _{SS} | SA | SA | SA | V _{SS} | Q10 | D9 | D1 |
| P | Q35 | D35 | Q26 | SA | SA | C | SA | SA | Q9 | D0 | Q0 |
| R | TDO | TCK | SA | SA | SA | C# | SA | SA | SA | TMS | TDI |

NOTE:

1. BW2# controls writes to D18:D26
2. BW1# controls writes to D9:D17
3. Expansion address: 9A for 36Mb
4. BW3# controls writes to D27:D35
5. BW0# controls writes to D0:D8

Table 4: Ball Descriptions

| SYM | TYPE | DESCRIPTION |
|------------|--------|--|
| BW_# | Input | Synchronous Byte Writes: When LOW, these inputs cause their respective bytes to be registered and written if W# had initiated a WRITE cycle. These signals must meet setup and hold times around the rising edges of K and K# for each of the two rising edges comprising the WRITE cycle. See Ball Layout figures for signal to data relationships. |
| C C# | Input | Output Clock: This clock pair provides a user-controlled means of tuning device output data. The rising edge of C is used as the output timing reference for first output data. The rising edge of C# is used as the output reference for second output data. Ideally, C# is 180 degrees out of phase with C. C and C# may be tied HIGH to force the use of K and K# as the output reference clocks instead of having to provide C and C# clocks. If tied HIGH, these inputs may not be allowed to toggle during device operation. |
| D_ | Input | Synchronous Data Inputs: Input data must meet setup and hold times around the rising edges of K and K# during WRITE operations. See Ball Layout figures for ball site location of individual signals. The x18 device uses D0:D17, and the x36 device uses D0:D35. |
| K K# | Input | Input Clock: This input clock pair registers address and control inputs on the rising edge of K, and registers data on the rising edge of K and the rising edge of K#. K# is ideally 180 degrees out of phase with K. All synchronous inputs must meet setup and hold times around the clock rising edges. |
| R# | Input | Synchronous Read: When LOW, this input causes the address inputs to be registered and a READ cycle to be initiated. This input must meet setup and hold times around the rising edge of K. |
| SA | Input | Synchronous Address Inputs: These inputs are registered and must meet the setup and hold times around the rising edge of K. See Ball Layout figures for address expansion inputs. All transactions operate on a burst of two words (one clock period of bus activity). These inputs are ignored when both ports are deselected. |
| TCK | Input | IEEE 1149.1 Clock Input: 2.5V I/O levels. This ball must be tied to V _{SS} if the JTAG function is not used in the circuit. |
| TMS TDI | Input | IEEE 1149.1 Test Inputs: 2.5V I/O levels. These balls may be left as No Connects if the JTAG function is not used in the circuit. |
| VREF | Input | HSTL Input Reference Voltage: Nominally V _{DDQ} /2, but may be adjusted to improve system noise margin. Provides a reference voltage for the HSTL input buffer trip point. |
| W# | Input | Synchronous Write: When LOW, this input causes the address inputs to be registered and a WRITE cycle to be initiated. This input must meet setup and hold times around the rising edge of K. |
| ZQ | Input | Output Impedance Matching Input: This input is used to tune the device outputs to the system data bus impedance. DQ output impedance is set to 0.2 x R _Q , where R _Q is a resistor from this ball to ground. Alternately, this ball can be connected directly to V _{DDQ} to enable the minimum impedance mode. This ball cannot be connected directly to GND or left unconnected. |
| CQ#, CQ | Output | Synchronous Echo Clock Outputs: The edges of these outputs are tightly matched to the synchronous data outputs and can be used as data valid indication. These signals run freely and do not stop when Q tri-states. |
| Q_ | Output | Synchronous Data Outputs: Output data is synchronized to the respective C and C# or to K and K# rising edges if C and C# are tied HIGH. This bus operates in response to R# commands. See Ball Layout figures for ball site location of individual signals. The x18 device uses Q0–Q17. The x36 device uses Q0–Q35. |
| TDO | Output | IEEE 1149.1 Test Output: 2.5V I/O level. |
| VDD | Supply | Power Supply: 2.5V nominal. See DC Electrical Characteristics and Operating Conditions for range. |
| VDDQ | Supply | Power Supply: Isolated Output Buffer Supply. Nominally, 1.5V. 1.8V is also permissible. See DC Electrical Characteristics and Operating Conditions for range. |
| VSS | Supply | Power Supply: GND. |
| NC | – | No Connect: These balls are internally connected to the die, but have no function and may be left not connected to board to minimize ball count. |

**Figure 4:
Bus Cycle State Diagram**

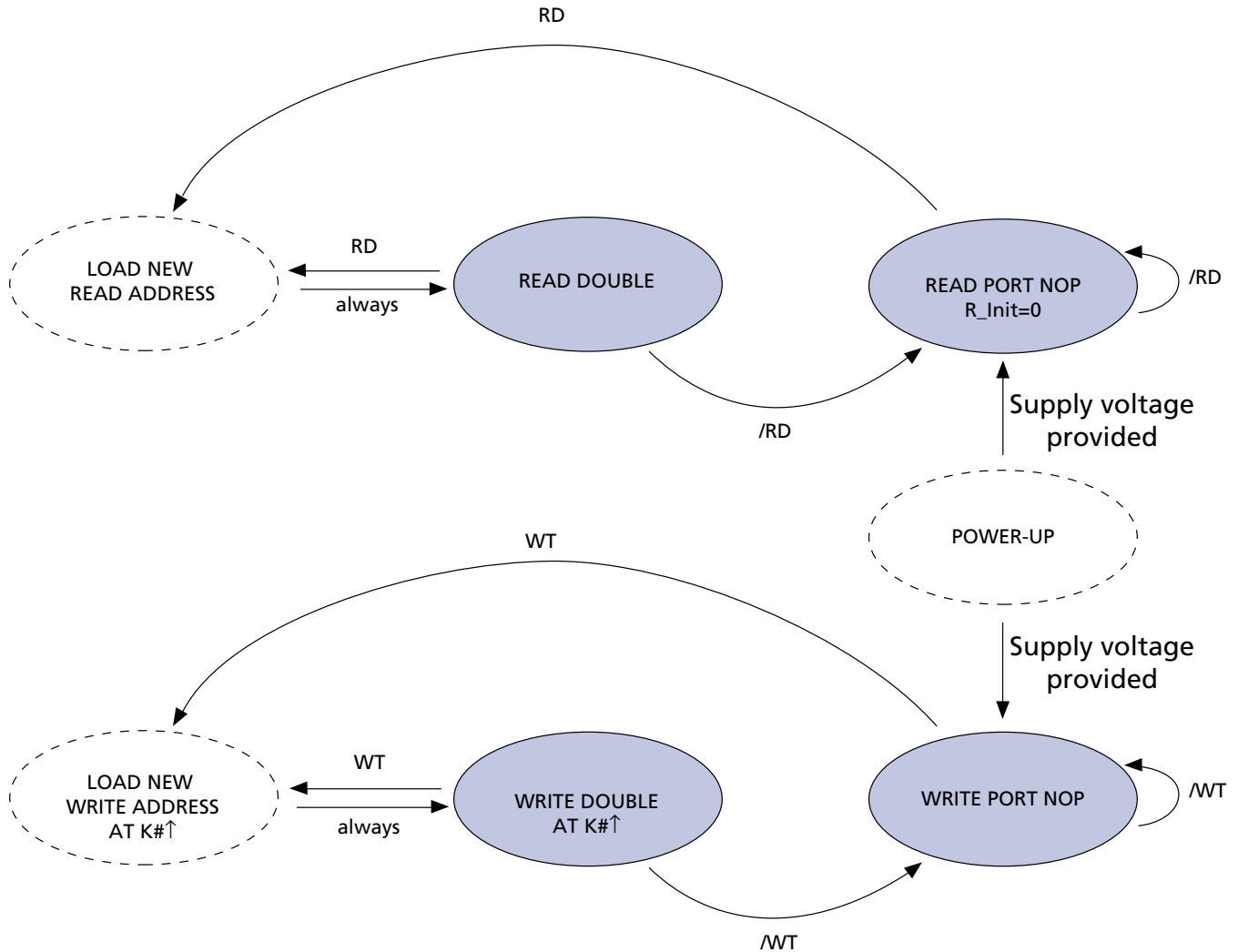

NOTE:

1. The address is concatenated with one additional internal LSB to facilitate BURST operation. The address order is always fixed as: xxx...xxx+0, xxx...xxx+1. Bus cycle is terminated at the end of this sequence (burst count = 2).
2. State transitions: RD = (R# = LOW); WT = (W# = LOW).
3. Read and write state machines can be simultaneously active.
4. State machine, control timing sequence is controlled by K.

Table 5: Truth Table

Notes 1–6

| OPERATION | K | R# | W# | D OR Q | D OR Q |
|---|---------|----|----|------------------------|--------------------------------|
| WRITE Cycle: Load address, input write data on consecutive K rising edges | L→H | X | L | DA(A0) at K(t)↑ | DA(A0 + 1) at K#(t + 1)↑ |
| READ Cycle: Load address, output data on consecutive C and C# rising edges | L→H | L | X | QA(A0) at C#(t)↑ | QA(A0 + 1) at C(t + 1)↑ |
| NOP: No operation | L→H | H | H | D = X Q = High-Z | D = X Q = High-Z |
| STANDBY: Clock stopped | Stopped | X | X | Previous State | Previous State |

Table 6: BYTE WRITE Operation

Notes 7, 8

| OPERATION | K | K# | BW0# | BW1# |
|---------------------------------|-----|-----|------|------|
| WRITE D0-17 at K rising edge | L→H | | 0 | 0 |
| WRITE D0-17 at K# rising edge | | L→H | 0 | 0 |
| WRITE D0-8 at K rising edge | L→H | | 0 | 1 |
| WRITE D0-8 at K# rising edge | | L→H | 0 | 1 |
| WRITE D9-17 at K rising edge | L→H | | 1 | 0 |
| WRITE D9-17 at K# rising edge | | L→H | 1 | 0 |
| WRITE nothing at K rising edge | L→H | | 1 | 1 |
| WRITE nothing at K# rising edge | | L→H | 1 | 1 |

NOTE:

1. X means "Don't Care." H means logic HIGH. L means logic LOW. ↑ means rising edge; ↓ means falling edge.
2. Data inputs are registered at K and K# rising edges. Data outputs are delivered at C and C# rising edges, except if C and C# are HIGH, then data outputs are delivered at K and K# rising edges.
3. R# and W# must meet setup and hold times around the rising edge (LOW to HIGH) of K and are registered at the rising edge of K.
4. This device contains circuitry that will ensure the outputs will be in High-Z during power-up.
5. Refer to state diagram and timing diagrams for clarification. A0 refers to the initial address input during a WRITE or READ cycle. A0 + 1 refers to the next internal burst address in accordance with the burst sequence.
6. It is recommended that K = K# = C = C# when clock is stopped. This is not essential but permits most rapid restart by overcoming transmission line charging symmetrically.
7. Assumes a WRITE cycle was initiated. BW0# and BW1# can be altered for any portion of the BURST WRITE operation provided that the setup and hold requirements are satisfied.
8. This table illustrates operation for x18 devices. The x36 device operation is similar, except for the addition of BW2# (controls D18:D26) and BW3# (controls D27:D35).



Absolute Maximum Ratings

Voltage on V_{DD} Supply Relative to V_{SS}..... -0.5V to +3.4V
 Voltage on V_{DDQ} Supply
 Relative to V_{SS} -0.5V to +V_{DD}
 V_{IN} -0.5V to V_{DD} +0.5V
 Storage Temperature -55°C to +125°C
 Junction Temperature +125°C
 Short Circuit Output Current ±70mA

Stresses greater than those listed under Absolute Maximum Ratings may cause permanent damage to the device. This is a stress rating only, and functional operation of the device at these or any other conditions above those indicated in the operational sections of this specification is not implied. Exposure to absolute maximum rating conditions for extended periods may affect reliability.

Maximum Junction Temperature depends upon package type, cycle time, loading, ambient temperature, and airflow.

Table 7: DC Electrical Characteristics and Operating Conditions

Notes appear following parameter tables on page 14; 0°C ≤ T_A ≤ +70°C; V_{DD} = 2.5V ±0.1V unless otherwise noted

| DESCRIPTION | CONDITIONS | SYMBOL | MIN | MAX | UNITS | NOTES |
|-------------------------------|--|-----------------------|----------------------------|----------------------------|-------|---------|
| Input High (Logic 1) Voltage | | V _{IH} (DC) | V _{REF} + 0.1 | V _{DDQ} + 0.3 | V | 3, 4 |
| Input Low (Logic 0) Voltage | | V _{IL} (DC) | -0.3 | V _{REF} - 0.1 | V | 3, 4 |
| Clock Input Signal Voltage | | V _{IN} | -0.3 | V _{DDQ} + 0.3 | V | 3, 4 |
| Input Leakage Current | 0V ≤ V _{IN} ≤ V _{DDQ} | I _{LI} | -5 | 5 | μA | |
| Output Leakage Current | Output(s) disabled, 0V ≤ V _{IN} ≤ V _{DDQ} (Q) | I _{LO} | -5 | 5 | μA | |
| Output High Voltage | I _{OH} ≤ 0.1mA | V _{OH} (LOW) | V _{DDQ} - 0.2 | V _{DDQ} | V | 3, 5, 6 |
| | Note 1 | V _{OH} | V _{DDQ} /2 - 0.12 | V _{DDQ} /2 + 0.12 | V | 3, 5, 6 |
| Output Low Voltage | I _{OL} ≤ 0.1mA | V _{OL} (LOW) | V _{SS} | 0.2 | V | 3, 5, 6 |
| | Note 2 | V _{OL} | V _{DDQ} /2 - 0.12 | V _{DDQ} /2 + 0.12 | V | 3, 5, 6 |
| Supply Voltage | | V _{DD} | 2.4 | 2.6 | V | 3 |
| Isolated Output Buffer Supply | | V _{DDQ} | 1.4 | 1.9 | V | 3, 7 |
| Reference Voltage | | V _{REF} | 0.68 | 0.95 | V | 3 |

Table 8: AC Electrical Characteristics and Operating Conditions

Notes appear following parameter tables on page 14; 0°C ≤ T_A ≤ +70°C; V_{DD} = 2.5V ±0.1V unless otherwise noted

| DESCRIPTION | CONDITIONS | SYMBOL | MIN | MAX | UNITS | NOTES |
|------------------------------|------------|----------------------|------------------------|------------------------|-------|---------|
| Input High (Logic 1) Voltage | | V _{IH} (AC) | V _{REF} + 0.2 | – | V | 3, 4, 8 |
| Input Low (Logic 0) Voltage | | V _{IL} (AC) | – | V _{REF} - 0.2 | V | 3, 4, 8 |

Table 9: I_{DD} Operating Conditions and Maximum Limits

 Notes appear following parameter tables on page 14; 0°C ≤ T_A ≤ +70°C; V_{DD} = 2.5V ±0.1V unless otherwise noted

| DESCRIPTION | CONDITIONS | SYMBOL | TYP | MAX | | | UNITS | NOTES |
|---|--|--------------------------------|-----|------------|------------|------------|-------|--------|
| | | | | -6 | -7.5 | -10 | | |
| Operating Supply Current: DDR | All inputs ≤ V _{IL} or ≥ V _{IH} ; Cycle time ≥ t _{KHKH} (MIN); Outputs open; 100% bus utilization; 50% address and data bits toggling on each clock cycle | I _{DD} x18 x36 | TBD | 400 500 | 310 400 | 225 300 | mA | 9, 10 |
| Standby Supply Current: NOP | t _{KHKH} = t _{KHKH} (MIN); Device in NOP state; All addresses/data static | I _{SB1} x18 x36 | TBD | 150 160 | 125 135 | 110 120 | mA | 10, 11 |
| Stop Clock Current | Cycle time = 0; Input Static | I _{SB} | TBD | 75 | 75 | 75 | mA | 10 |
| Output Supply Current: DDR (Information only) | C _L = 15pF | I _{DDQ} x18 x36 | TBD | 21 47 | 17 38 | 13 29 | mA | 12 |

Table 10: Capacitance

Note 13; notes appear following parameter tables on page 14

| DESCRIPTION | CONDITIONS | SYMBOL | TYP | MAX | UNITS |
|-----------------------------------|----------------------------------|-----------------|-----|-----|-------|
| Address/Control Input Capacitance | T _A = 25°C; f = 1 MHz | C _I | 4.5 | 5.5 | pF |
| Output Capacitance (Q) | | C _O | 6 | 7 | pF |
| Clock Capacitance | | C _{CK} | 5.5 | 6.5 | pF |

Table 11: Thermal Resistance

Note 13; notes appear following parameter tables on page 14

| DESCRIPTION | CONDITIONS | SYMBOL | TYP | UNITS | NOTES |
|---------------------------------------|--|-----------------|------|-------|-------|
| Junction to Ambient (Airflow of 1m/s) | Soldered on a 4.25 x 1.125 inch, 4-layer printed circuit board | θ _{JA} | 19.4 | °C/W | 14 |
| Junction to Case (Top) | | θ _{JC} | 1.0 | °C/W | |
| Junction to Balls (Bottom) | | θ _{JB} | 9.6 | °C/W | 15 |

Table 12: AC Electrical Characteristics and Recommended Operating Conditions

 Notes 13, 16–19, notes appear following parameter tables on page 14; °C ≤ T_A ≤ +70°C; T_J ≤ +95°C; V_{DD} = 2.5V ±0.1V

| DESCRIPTION | SYMBOL | -6 | | -7.5 | | -10 | | UNITS | NOTES |
|---------------------------------------|---------------------|-------|------|-------|------|-------|------|-------|-------|
| | | MIN | MAX | MIN | MAX | MIN | MAX | | |
| Clock | | | | | | | | | |
| Clock cycle time (K, K#, C, C#) | t _{KHKH} | 6.0 | | 7.5 | | 10 | | ns | |
| Clock HIGH time (K, K#, C, C#) | t _{KHKL} | 2.4 | | 3.0 | | 3.5 | | ns | |
| Clock LOW time (K, K#, C, C#) | t _{KLKH} | 2.4 | | 3.0 | | 3.5 | | ns | |
| Clock to clock# (K→K#↑, C→C#↑) | t _{KHK#H} | 2.7 | | 3.4 | | 4.6 | | ns | |
| Clock# to clock (K#→K, C#→C) | t _{K#HKH} | 2.7 | | 3.4 | | 4.6 | | ns | |
| Clock to data clock (K→C↑, K#↑→C#↑) | t _{KHCH} | 0.0 | 2.0 | 0.0 | 2.5 | 0.0 | 3.0 | ns | |
| Output Times | | | | | | | | | |
| C, C# HIGH to output valid | t _{CHQV} | | 2.5 | | 3.0 | | 3.0 | ns | |
| C, C# HIGH to output hold | t _{CHQX} | 1.2 | | 1.2 | | 1.2 | | ns | |
| C HIGH to output High-Z | t _{CHQZ} | | 2.5 | | 3.0 | | 3.0 | ns | 20 |
| C HIGH to output Low-Z | t _{CHQX1} | 1.2 | | 1.2 | | 1.2 | | ns | 20 |
| C, C# HIGH to CQ, CQ# HIGH | t _{CHCQH} | 1.2 | 2.6 | 1.2 | 3.2 | 1.2 | 3.2 | ns | |
| CQ, CQ# HIGH to output valid | t _{CQHQV} | | 0.40 | | 0.45 | | 0.50 | ns | |
| CQ, CQ# HIGH to output hold | t _{CQHQX} | -0.40 | | -0.45 | | -0.50 | | ns | |
| CQ HIGH to output High-Z | t _{CQHQZ} | | 0.40 | | 0.45 | | 0.50 | ns | 20 |
| CQ HIGH to output Low-Z | t _{CQHQX1} | -0.40 | | -0.45 | | -0.50 | | | 20 |
| Setup Times | | | | | | | | | |
| Address valid to K rising edge | t _{AVKH} | 0.7 | | 0.8 | | 1.0 | | ns | 16 |
| Control inputs valid to K rising edge | t _{IVKH} | 0.7 | | 0.8 | | 1.0 | | ns | 16 |
| Data-in valid to K, K# rising edge | t _{DVKH} | 0.7 | | 0.8 | | 1.0 | | ns | 16 |
| Hold Times | | | | | | | | | |
| K rising edge to address hold | t _{KHAX} | 0.7 | | 0.8 | | 1.0 | | ns | 16 |
| K rising edge to control inputs hold | t _{KHIX} | 0.7 | | 0.8 | | 1.0 | | ns | 16 |
| K, K# rising edge to data-in hold | t _{KHDX} | 0.7 | | 0.8 | | 1.0 | | ns | 16 |

Notes

1. Outputs are impedance-controlled. $|I_{OH}| = (V_{DDQ}/2)/(RQ/5)$ for values of $175\Omega \leq RQ \leq 350\Omega$.
2. Outputs are impedance-controlled. $I_{OL} = (V_{DDQ}/2)/(RQ/5)$ for values of $175\Omega \leq RQ \leq 350\Omega$.
3. All voltages referenced to V_{SS} (GND).
4. Overshoot: $V_{IH(AC)} \leq V_{DD} + 0.7V$ for $t \leq t_{KHKH}/2$
Undershoot: $V_{IL(AC)} \geq -0.5V$ for $t \leq t_{KHKH}/2$
Power-up: $V_{IH} \leq V_{DDQ} + 0.3V$ and $V_{DD} \leq 2.4V$ and $V_{DDQ} \leq 1.4V$ for $t \leq 200ms$
During normal operation, V_{DDQ} must not exceed V_{DD}. R# and W# signals may not have pulse widths less than t_{KHKL} (MIN) or operate at cycle rates less than t_{KHKH} (MIN).
5. AC load current is higher than the shown DC values. AC I/O curves are available upon request.
6. HSTL outputs meet JEDEC HSTL Class I and Class II standards.
7. The nominal value of V_{DDQ} may be set within the range of 1.5V to 1.8V DC, and the variation of V_{DDQ} must be limited to $\pm 0.1V$ DC.
8. To maintain a valid level, the transitioning edge of the input must:
 - a. Sustain a constant slew rate from the current AC level through the target AC level, $V_{IL(AC)}$ or $V_{IH(AC)}$.
 - b. Reach at least the target AC level.
 - c. After the AC target level is reached, continue to maintain at least the target DC level, $V_{IL(DC)}$ or $V_{IH(DC)}$.
9. IDD is specified with no output current and increases with faster cycle times. IDD increases with faster cycle times and greater output loading. Typical value is measured at 6ns cycle time.
10. Typical values are measured at V_{DD} = 2.5V, V_{DDQ} = 1.5V, and temperature = 25°C.
11. NOP currents are valid when entering NOP after all pending READ and WRITE cycles are completed.
12. Average I/O current and power is provided for informational purposes only and is not tested. Calculation assumes that all outputs are loaded with C_L (in farads), f = input clock frequency, half of outputs toggle at each transition (n = 18 for the x36), C_O = 6pF, V_{DDQ} = 1.5V and uses the equations: Average I/O Power as dissipated by the SRAM is: $P = 0.5 \times n \times f \times V_{DDQ}^2 \times (C_L + 2C_O)$.
Average IDDQ = $n \times f \times V_{DDQ} \times (C_L + C_O)$.
13. This parameter is sampled.
14. Average thermal resistance between the die and the case top surface per MIL SPEC 883 Method 1012.1.
15. Junction temperature is a function of total device power dissipation and device mounting environment. Measured per SEMI G38-87.
16. This is a synchronous device. All addresses, data, and control lines must meet the specified setup and hold times for all latching clock edges.
17. Control input signals may not be operated with pulse widths less than t_{KHKL} (MIN).
18. Test conditions as specified with the output loading as shown in Figure 5, unless otherwise noted.
19. If C and C# are tied HIGH, then K and K# become the references for C and C# timing parameters.
20. t_{CHQX1} is greater than t_{CHQZ} at any given voltage and temperature.

AC Test Conditions

Input pulse levels0.25V to 1.25V
 Input rise and fall times0.7ns
 Input timing reference levels 0.75V
 Output reference levels V_{DDQ}/2
 Z_Q for 50Ω impedance250Ω
 Output load See Figure 5

**Figure 5:
Output Load Equivalent**

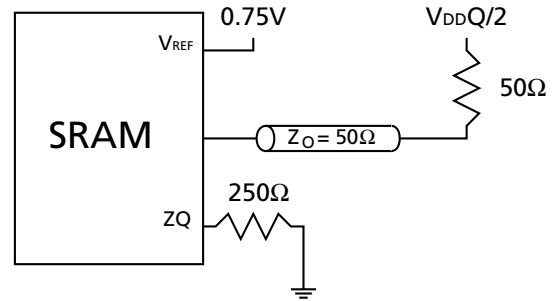
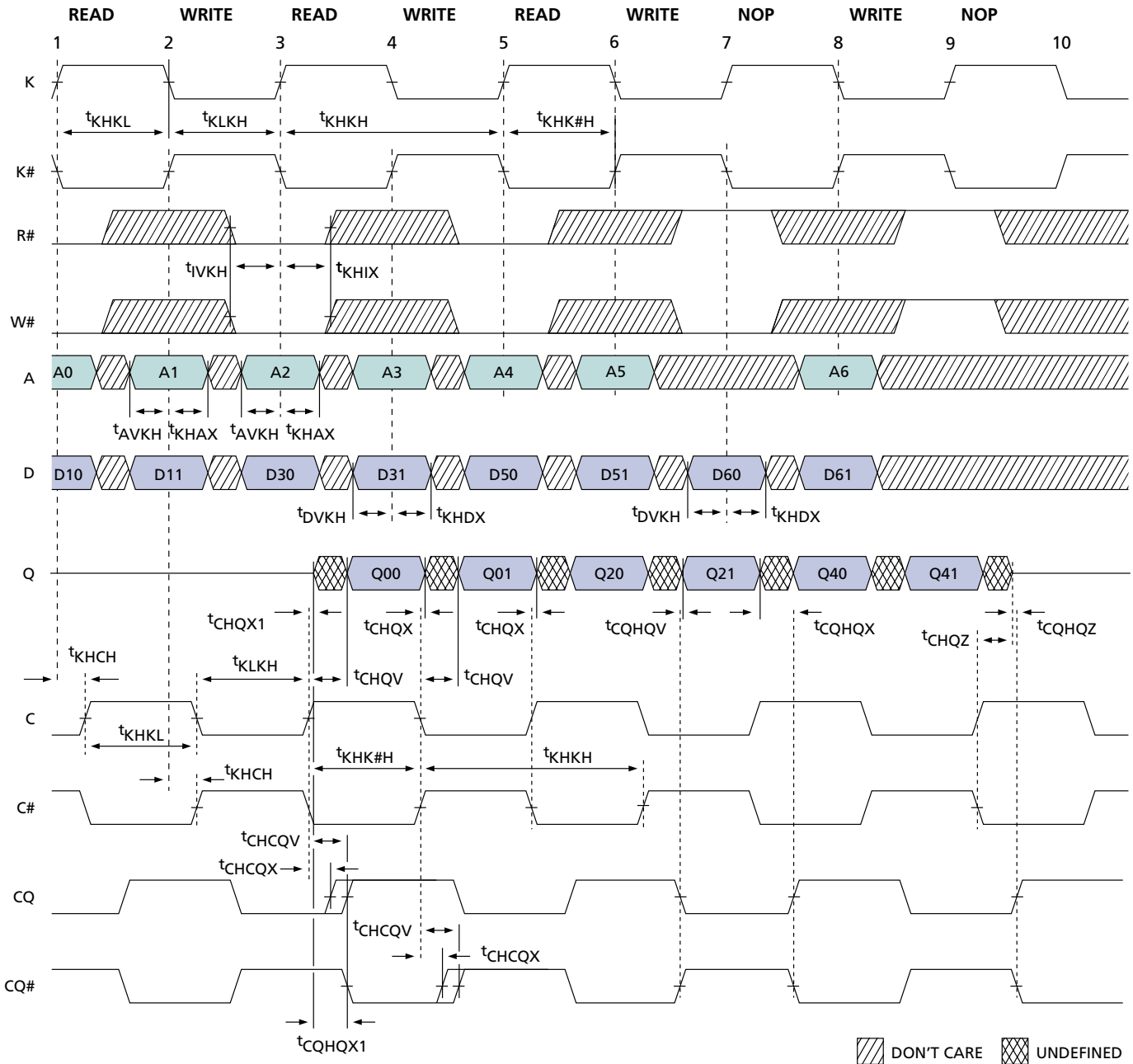

Figure 6:
READ/WRITE Timing



NOTE:

1. Q00 refers to output from address A0. Q01 refers to output from the next internal burst address following A0, i.e., A0 + 1.
2. Outputs are disabled (High-Z) one clock cycle after a NOP.
3. In this example, if address A0 = A1, then data Q00 = D10 and Q01 = D11. Write data is forwarded immediately as read results. (This note applies to whole diagram.)

IEEE 1149.1 Serial Boundary Scan (JTAG)

The SRAM incorporates a serial boundary scan test access port (TAP). This port operates in accordance with IEEE Standard 1149.1-1990 but does not have the set of functions required for full 1149.1 compliance. These functions from the IEEE specification are excluded because their inclusion places an added delay in the critical speed path of the SRAM. Note that the TAP controller functions in a manner that does not conflict with the operation of other devices using 1149.1 fully-compliant TAPs. The TAP operates using JEDEC-standard 2.5V I/O logic levels.

The SRAM contains a TAP controller, instruction register, boundary scan register, bypass register, and ID register.

Disabling the JTAG Feature

It is possible to operate the SRAM without using the JTAG feature. To disable the TAP controller, TCK must be tied LOW (V_{SS}) to prevent clocking of the device. TDI and TMS are internally pulled up and may be unconnected. Alternately, they may be connected to V_{DD} through a pull-up resistor. TDO should be left unconnected. Upon power-up, the device will come up in a reset state which will not interfere with the operation of the device.

**Figure 7:
TAP Controller State Diagram**

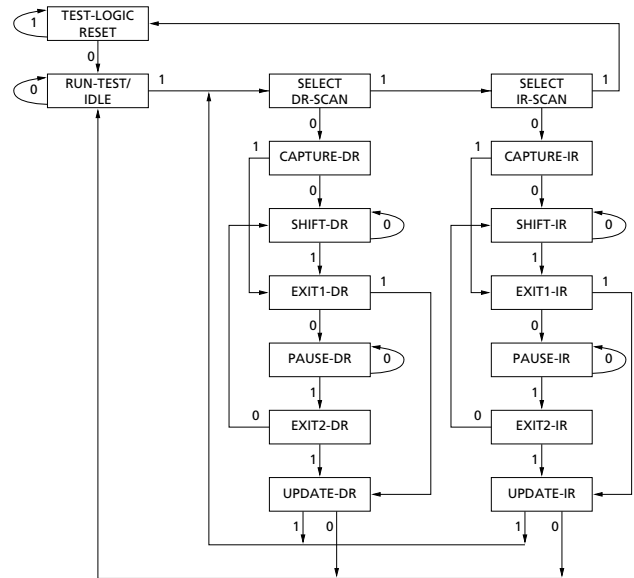

NOTE:

The 0/1 next to each state represents the value of TMS at the rising edge of TCK.

Test Access Port (TAP) Test Clock (TCK)

The test clock is used only with the TAP controller. All inputs are captured on the rising edge of TCK. All outputs are driven from the falling edge of TCK.

Test MODE SELECT (TMS)

The TMS input is used to give commands to the TAP controller and is sampled on the rising edge of TCK. It is allowable to leave this ball unconnected if the TAP is not used. The ball is pulled up internally, resulting in a logic HIGH level.

Test Data-In (TDI)

The TDI ball is used to serially input information into the registers and can be connected to the input of any of the registers. The register between TDI and TDO is chosen by the instruction that is loaded into the TAP instruction register. For information on loading the instruction register, see Figure 7. TDI is internally pulled up and can be unconnected if the TAP is unused in an application. TDI is connected to the most significant bit (MSB) of any register, as illustrated in Figure 8.

Test Data-Out (TDO)

The TDO output ball is used to serially clock data-out from the registers. The output is active depending upon the current state of the TAP state machine, as shown in Figure 7. The output changes on the falling edge of TCK. TDO is connected to the least significant bit (LSB) of any register, as depicted in Figure 8.

Performing a TAP RESET

A RESET is performed by forcing TMS HIGH (V_{DD}) for five rising edges of TCK. This RESET does not affect the operation of the SRAM and may be performed while the SRAM is operating.

At power-up, the TAP is reset internally to ensure that TDO comes up in a High-Z state.

TAP Registers

Registers are connected between the TDI and TDO balls and allow data to be scanned into and out of the SRAM test circuitry. Only one register can be selected at a time through the instruction register. Data is serially loaded into the TDI ball on the rising edge of TCK. Data is output on the TDO ball on the falling edge of TCK.

Instruction Register

Three-bit instructions can be serially loaded into the instruction register. This register is loaded when it is placed between the TDI and TDO balls, as shown in Figure 8. Upon power-up, the instruction register is loaded with the IDCODE instruction. It is also loaded with the IDCODE instruction if the controller is placed in a reset state, as described in the previous section.

When the TAP controller is in the Capture-IR state, the two LSBs are loaded with a binary “01” pattern to allow for fault isolation of the board-level serial test data path.

Bypass Register

To save time when serially shifting data through registers, it is sometimes advantageous to skip certain chips. The bypass register is a single-bit register that can be placed between the TDI and TDO balls. This allows data to be shifted through the SRAM with minimal delay. The bypass register is set LOW (V_{SS}) when the BYPASS instruction is executed.

**Figure 8:
TAP Controller Block Diagram**

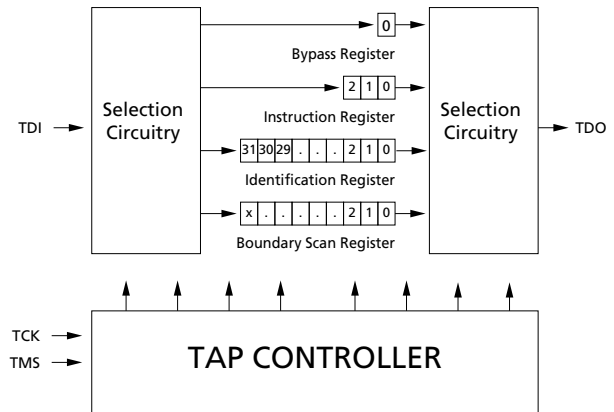

NOTE:

X = 106.

Boundary Scan Register

The boundary scan register is connected to all the input and bidirectional balls on the SRAM. The SRAM has a 107-bit-long register.

The boundary scan register is loaded with the contents of the RAM I/O ring when the TAP controller is in the Capture-DR state and is then placed between the TDI and TDO balls when the controller is moved to the Shift-DR state. The EXTEST, SAMPLE/PRELOAD, and SAMPLE Z instructions can be used to capture the contents of the I/O ring.

The Boundary Scan Order tables show the order in which the bits are connected. Each bit corresponds to one of the balls on the SRAM package. The MSB of the register is connected to TDI, and the LSB is connected to TDO.

Identification (ID) Register

The ID register is loaded with a vendor-specific, 32-bit code during the Capture-DR state when the IDCODE command is loaded in the instruction register. The IDCODE is hardwired into the SRAM and can be shifted out when the TAP controller is in the Shift-DR state. The ID register has a vendor code and other information described in the Identification Register

TAP Instruction Set

Overview

Eight different instructions are possible with the three-bit instruction register. All combinations are listed in the Instruction Codes table. Three of these instructions are listed as RESERVED and should not be used. The other five instructions are described in detail below.

The TAP controller used in this SRAM is not fully compliant to the 1149.1 convention because some of the mandatory 1149.1 instructions are not fully implemented. The TAP controller cannot be used to load address, data or control signals into the SRAM and cannot preload the I/O buffers. The SRAM does not implement the 1149.1 commands EXTEST or INTEST or the PRELOAD portion of SAMPLE/PRELOAD; rather, it performs a capture of the I/O ring when these instructions are executed.

EXTEST

EXTEST is a mandatory 1149.1 instruction which is to be executed whenever the instruction register is loaded with all 0s. EXTEST is not implemented in this SRAM TAP controller; therefore, this device is not 1149.1-compliant.

The TAP controller does recognize an all-0 instruction. When an EXTEST instruction is loaded into the instruction register, the SRAM responds as if a SAMPLE/PRELOAD instruction has been loaded. EXTEST does not place the SRAM outputs (including CQ and CQ#) in a High-Z state.

IDCODE

The IDCODE instruction causes a vendor-specific, 32-bit code to be loaded into the instruction register. It also places the instruction register between the TDI

and TDO balls and allows the IDCODE to be shifted out of the device when the TAP controller enters the Shift-DR state. The IDCODE instruction is loaded into the instruction register upon power-up or whenever the TAP controller is given a test logic reset state.

SAMPLE Z

The SAMPLE Z instruction causes the boundary scan register to be connected between the TDI and TDO balls when the TAP controller is in a Shift-DR state. It also places all SRAM outputs into a High-Z state.

SAMPLE/PRELOAD

SAMPLE/PRELOAD is a 1149.1 mandatory instruction. The PRELOAD portion of this instruction is not implemented, so the device TAP controller is not fully 1149.1-compliant.

Note that since the PRELOAD part of the command is not implemented, putting the TAP into the Update-DR state while performing a SAMPLE/PRELOAD instruction will have the same effect as the Pause-DR command.

BYPASS

When the BYPASS instruction is loaded in the instruction register and the TAP is placed in a Shift-DR state, the bypass register is placed between the TDI and TDO balls. The advantage of the BYPASS instruction is that it shortens the boundary scan path when multiple devices are connected together on a board.

Reserved

These instructions are not implemented but are reserved for future use. Do not use these instructions.

Figure 9: TAP Timing

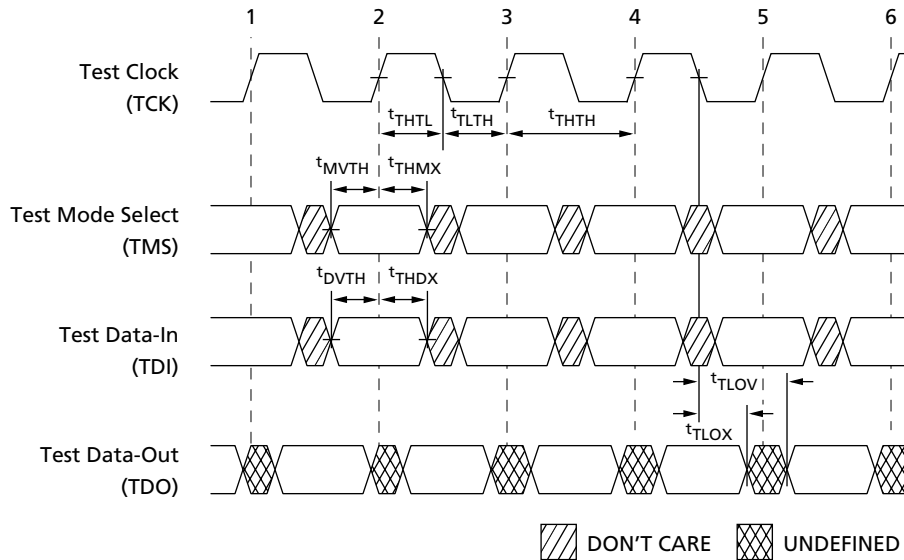

NOTE:

Timing for SRAM inputs and outputs is congruent with TDI and TDO, respectively, as shown in Figure 9.

Table 13: TAP DC Electrical Characteristics

Notes 1, 2; 0°C ≤ T_A ≤ +70°C; V_{DD} = 2.5V ±0.1V

| DESCRIPTION | SYMBOL | MIN | MAX | UNITS |
|-------------------------|-------------------|-----|-----|-------|
| Clock | | | | |
| Clock cycle time | t _{THTH} | 100 | | ns |
| Clock frequency | f _{TF} | | 10 | MHz |
| Clock HIGH time | t _{THTL} | 40 | | ns |
| Clock LOW time | t _{TLTH} | 40 | | ns |
| Output Times | | | | |
| TCK LOW to TDO unknown | t _{TLOX} | 0 | | ns |
| TCK LOW to TDO valid | t _{TLOV} | | 20 | ns |
| TDI valid to TCK HIGH | t _{DVTH} | 10 | | ns |
| TCK HIGH to TDI invalid | t _{THDX} | 10 | | ns |
| Setup Times | | | | |
| TMS setup | t _{MVTH} | 10 | | ns |
| Capture setup | t _{CS} | 10 | | ns |
| Hold Times | | | | |
| TMS hold | t _{THMX} | 10 | | ns |
| Capture hold | t _{CH} | 10 | | ns |

NOTE:

1. t_{CS} and t_{CH} refer to the setup and hold time requirements of latching data from the boundary scan register.
2. Test conditions are specified using the load in Figure 10.

TAP AC Test Conditions

Input pulse levels Vss to 1.8V
 Input rise and fall times 1ns
 Input timing reference levels 0.9V
 Output reference levels 0.9V
 Test load termination supply voltage 0.9V

**Figure 10:
TAP AC Output Load Equivalent**

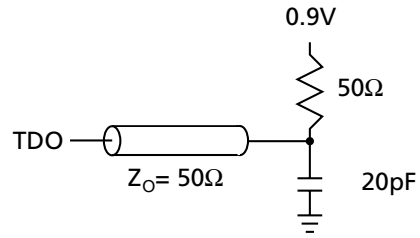

Table 14: TAP DC Electrical Characteristics and Operating Conditions

Note 2; $0^{\circ}\text{C} \leq T_A \leq +70^{\circ}\text{C}$; $V_{DD} = 2.5\text{V} \pm 0.1\text{V}$ unless otherwise noted

| DESCRIPTION | CONDITIONS | SYMBOL | MIN | MAX | UNITS | NOTES |
|------------------------------|--|-----------|------|----------------|---------------|-------|
| Input High (Logic 1) Voltage | | V_{IH} | 1.7 | $V_{DD} + 0.3$ | V | 1, 2 |
| Input Low (Logic 0) Voltage | | V_{IL} | -0.3 | 0.7 | V | 1, 2 |
| Input Leakage Current | $0\text{V} \leq V_{IN} \leq V_{DD}$ | I_{LI} | -5.0 | 5.0 | μA | 2 |
| Output Leakage Current | Output(s) disabled, $0\text{V} \leq V_{IN} \leq V_{DD}$ | I_{LO} | -5.0 | 5.0 | μA | 2 |
| Output Low Voltage | $I_{OLC} = 100\mu\text{A}$ | V_{OL1} | | 0.2 | V | 1, 2 |
| Output Low Voltage | $I_{OLT} = 2\text{mA}$ | V_{OL2} | | 0.7 | V | 1, 2 |
| Output High Voltage | $I_{OHC} = -100\mu\text{A}$ | V_{OH1} | 2.1 | | V | 1, 2 |
| Output High Voltage | $I_{OHT} = -2\text{mA}$ | V_{OH1} | 1.7 | | V | 1, 2 |

NOTE:

1. All voltages referenced to Vss (GND).
2. This table defines DC values for TAP control and data balls only. The DQ SRAM balls used in JTAG operation will have the DC values as defined in Table 7, "DC Electrical Characteristics and Operating Conditions," on page 11.

Table 15: Identification Register Definitions

| INSTRUCTION FIELD | ALL DEVICES | DESCRIPTION |
|------------------------------------|-------------------|--|
| REVISION NUMBER (31:28) | 000 | Revision number. |
| DEVICE ID (28:12) | 00def0wx0t0q0b0s0 | def = 010 for 36Mb density def = 001 for 18Mb density wx = 11 for x36 width wx = 10 for x18 width wx = 01 for x8 width t = 1 for DLL version t = 0 for non-DLL version q = 1 for QDR q = 0 for DDR b = 1 for 4-word burst b = 0 for 2-word burst s = 1 for separate I/O s = 0 for common I/O |
| MICRON JEDEC ID CODE (11:1) | 00000101100 | Allows unique identification of SRAM vendor. |
| ID Register Presence Indicator (0) | 1 | Indicates the presence of an ID register. |

Table 16: Scan Register Sizes

| REGISTER NAME | BIT SIZE |
|---------------|----------|
| Instruction | 3 |
| Bypass | 1 |
| ID | 32 |
| Boundary Scan | 107 |

Table 17: Instruction Codes

| INSTRUCTION | CODE | DESCRIPTION |
|--------------------|------|---|
| EXTEST | 000 | Captures I/O ring contents. Places the boundary scan register between TDI and TDO. This instruction is not 1149.1-compliant. |
| IDCODE | 001 | Loads the ID register with the vendor ID code and places the register between TDI and TDO. This operation does not affect SRAM operations. |
| SAMPLE Z | 010 | Captures I/O ring contents. Places the boundary scan register between TDI and TDO. Forces all SRAM output drivers to a High-Z state. |
| RESERVED | 011 | Do Not Use: This instruction is reserved for future use. |
| SAMPLE/ PRELOAD | 100 | Captures I/O ring contents. Places the boundary scan register between TDI and TDO. This instruction does not implement 1149.1 preload function and is therefore not 1149.1-compliant. |
| RESERVED | 101 | Do Not Use: This instruction is reserved for future use. |
| RESERVED | 110 | Do Not Use: This instruction is reserved for future use. |
| BYPASS | 111 | Places the bypass register between TDI and TDO. This operation does not affect SRAM operations. |

Table 18: Boundary Scan (Exit) Order

| BIT# | FBGA BALL |
|------|-----------|
| 1 | 6R |
| 2 | 6P |
| 3 | 6N |
| 4 | 7P |
| 5 | 7N |
| 6 | 7R |
| 7 | 8R |
| 8 | 8P |
| 9 | 9R |
| 10 | 11P |
| 11 | 10P |
| 12 | 10N |
| 13 | 9P |
| 14 | 10M |
| 15 | 11N |
| 16 | 9M |
| 17 | 9N |
| 18 | 11L |
| 19 | 11M |
| 20 | 9L |
| 21 | 10L |
| 22 | 11K |
| 23 | 10K |
| 24 | 9J |
| 25 | 9K |
| 26 | 10J |
| 27 | 11J |
| 28 | 11H |
| 29 | 10G |
| 30 | 9G |
| 31 | 11F |
| 32 | 11G |
| 33 | 9F |
| 34 | 10F |
| 35 | 11E |
| 36 | 10E |

| BIT# | FBGA BALL |
|------|-----------|
| 37 | 10D |
| 38 | 9E |
| 39 | 10C |
| 40 | 11D |
| 41 | 9C |
| 42 | 9D |
| 43 | 11B |
| 44 | 11C |
| 45 | 9B |
| 46 | 10B |
| 47 | 11A |
| 48 | 10A |
| 49 | 9A |
| 50 | 8B |
| 51 | 7C |
| 52 | 6C |
| 53 | 8A |
| 54 | 7A |
| 55 | 7B |
| 56 | 6B |
| 57 | 6A |
| 58 | 5B |
| 59 | 5A |
| 60 | 4A |
| 61 | 5C |
| 62 | 4B |
| 63 | 3A |
| 64 | 2A |
| 65 | 1A |
| 66 | 2B |
| 67 | 3B |
| 68 | 1C |
| 69 | 1B |
| 70 | 3D |
| 71 | 3C |
| 72 | 1D |

| BIT# | FBGA BALL |
|------|-----------|
| 73 | 2C |
| 74 | 3E |
| 75 | 2D |
| 76 | 2E |
| 77 | 1E |
| 78 | 2F |
| 79 | 3F |
| 80 | 1G |
| 81 | 1F |
| 82 | 3G |
| 83 | 2G |
| 84 | 1J |
| 85 | 2J |
| 86 | 3K |
| 87 | 3J |
| 88 | 2K |
| 89 | 1K |
| 90 | 2L |
| 91 | 3L |
| 92 | 1M |
| 93 | 1L |
| 94 | 3N |
| 95 | 3M |
| 96 | 1N |
| 97 | 2M |
| 98 | 3P |
| 99 | 2N |
| 100 | 2P |
| 101 | 1P |
| 102 | 3R |
| 103 | 4R |
| 104 | 4P |
| 105 | 5P |
| 106 | 5N |
| 107 | 5R |

**Figure 11:
165-Ball FBGA**

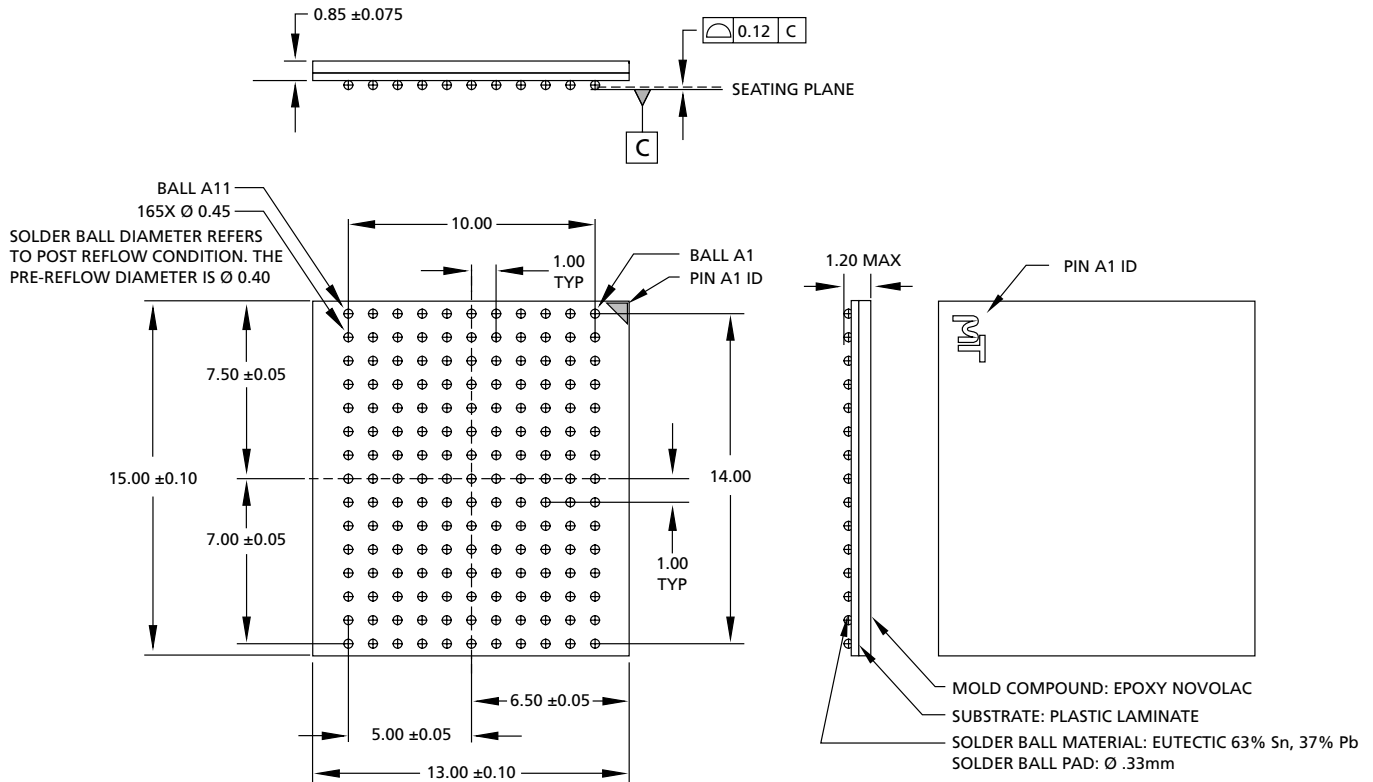

NOTE:

1. All dimensions are in millimeters.
2. Molding dimensions do not include protrusion; allowable mold protrusion is 0.25mm per side.

Data Sheet Designation

No Marking: This data sheet contains minimum and maximum limits specified over the complete power supply and temperature range for production devices. Although considered final, these specifications are subject to change, as further product development and data characterization sometimes occur.



8000 S. Federal Way, P.O. Box 6, Boise, ID 83707-0006, Tel: 208-368-3900

E-mail: prodmktg@micron.com, Internet: <http://www.micron.com>, Customer Comment Line: 800-932-4992

Micron, the M logo, and the Micron logo are trademarks and/or service marks of Micron Technology, Inc. QDR RAMs and Quad Data Rate RAMs comprise a new family of products developed by Cypress Semiconductor, IDT, and Micron Technology, Inc., NEC, and Samsung.

Document Revision History

| | |
|--|------|
| Rev. F, Pub 3/03 | 3/03 |
| • Updated JTAG Section | |
| • Removed Preliminary Status | |
| Rev. E, Pub 2/03 | 2/03 |
| • Added definitive notes to Figure 3 | |
| • Added definitive note to Table 9 | |
| • Updated Truth Table for clarity | |
| • Added 1.5V references | |
| • Update READ/WRITE Timing Diagram | |
| • Updated JTAG section to reflect 1149.1 specification compliance with EXTEST features | |
| • Updated JTAG description to reflect 1149.1 specification compliance with EXTEST feature | |
| • Added definitive note concerning SRAM (DQ) I/O balls used for JTAG DC values and timing | |
| • Changed process information in header to die revision indicator | |
| • Updated Thermal Resistance Values to Table 12: C _I = 4.5 TYP; 5.5 MAX C _O = 6 TYP; 7 MAX C _{CK} = 5.5 TYP; 6.5 MAX | |
| • Updated Thermal Resistance values to Table 12: J _A = 19.4 TYP J _C = 1.0 TYP J _B = 9.6 TYP | |
| • Added T _J ≤ +95°C to Table 13 | |
| • Modified Figure 2 regarding depth, configuration, and byte controls | |
| • Added definitive notes regarding I/O behavior during JTAG operation | |
| • Added definitive notes regarding IDD test conditions for read to write ratio | |
| • Removed note regarding AC derating information for full I/O range | |
| • Remove references to JTAG scan chain logic levels being at logic zero for NC pins in Tables 5 and 19 | |
| • Revised ball description for NC balls: These balls are internally connected to the die, but have no function and may be left not connected to the board to minimize ball count. | |
| Rev. D, Pub 6/02 | 6/02 |
| • Removed ADVANCE designation | |
| • Added note 8 on page 8 | |
| • Deleted note 6 on page 9 | |
| • Revised note 5 on page 10 | |
| • Added “t” and description to Device ID code | |
| Rev. C, Pub. 5/02, ADVANCE | 5/02 |
| • Fixed voltage range error in AC Electrical Characteristics and Operating Conditions table | |
| • Added new Output Times values | |
| Rev. B, Pub. 5/02, ADVANCE | 8/02 |
| • Updated DC Electrical Characteristics and Operating Conditions table | |
| • Added AC Electrical Characteristics and Operating Conditions table | |
| Rev. A, Pub. 4/02, ADVANCE | 4/02 |
| • New ADVANCE data sheet | |