

M5M467400/465400DJ,DTP -5,-6,-5S,-6S

M5M467800/465800DJ,DTP -5,-6,-5S,-6S

M5M465160DJ,DTP -5,-6,-5S,-6S

FAST PAGE MODE 67108864-BIT (16777216-WORD BY 4-BIT) DYNAMIC RAM
 FAST PAGE MODE 67108864-BIT (8388608-WORD BY 8-BIT) DYNAMIC RAM
 FAST PAGE MODE 67108864-BIT (4194304-WORD BY 16-BIT) DYNAMIC RAM

PRELIMINARY

Some of contents are subject to change without notice.

DESCRIPTION

The M5M467400/465400DJ,DTP is a 16777216-word by 4-bit, M5M467800/465800DJ,DTP is a 8388608-word by 8-bit, and M5M465160DJ,DTP is a 4194304-word by 16-bit dynamic RAMs, fabricated with the high performance CMOS process, and are suitable for large-capacity memory systems with high speed and low power dissipation.

FEATURES

Type name	RAS access time (max.ns)	CAS access time (max.ns)	Address access time (max.ns)	OE access time (max.ns)	Cycle time (min.ns)	Power dissipation (typ.mW)
M5M467400DXX-5,5S M5M467800DXX-5,5S	50	13	25	13	90	300
M5M467400DXX-6,6S M5M467800DXX-6,6S	60	15	30	15	110	250
M5M465400DXX-5,5S M5M465800DXX-5,5S	50	13	25	13	90	390
M5M465400DXX-6,6S M5M465800DXX-6,6S	60	15	30	15	110	325

Type name	RAS access time (max.ns)	CAS access time (max.ns)	Address access time (max.ns)	OE access time (max.ns)	Cycle time (min.ns)	Power dissipation (typ.mW)
M5M465160DXX-5,5S	50	13	25	13	90	420
M5M465160DXX-6,6S	60	15	30	15	110	390

XX=J,TP

- Standard 32 pin SOJ, 32 pin TSOP (M5M467400Dxx/M5M465400Dxx/M5M467800Dxx/M5M465800Dxx)
Standard 50 pin SOJ, 50 pin TSOP (M5M465160Dxx)
- Single 3.3 ± 0.3V supply
- Low stand-by power dissipation
1.8mW (Max) ----- LVCMOS input level
- Low operating power dissipation

M5M467400Dxx-5,5S / M5M467800Dxx-5,5S	-----	360.0mW (Max)
M5M467400Dxx-6,6S / M5M467800Dxx-6,6S	-----	324.0mW (Max)
M5M465400Dxx-5,5S / M5M465800Dxx-5,5S	-----	468.0mW (Max)
M5M465400Dxx-6,6S / M5M465800Dxx-6,6S	-----	432.0mW (Max)
M5M465160Dxx-5,5S	-----	504.0mW (Max)
M5M465160Dxx-6,6S	-----	468.0mW (Max)
- Self refresh capability*
Self refresh current ----- 400µA (Max)
- Fast-page mode, Read-modify-write, CAS before RAS refresh, Hidden refresh capabilities
- Early-write mode and OE to control output buffer impedance
- All inputs, outputs LVTTTL compatible and low capacitance
*: Applicable to self refresh version(M5M467400/465400/467800/465800/465160DJ,DTP-5S,-6S:option) only

ADDRESS

Part No.	Row Add.	Col. Add.	Refresh	Refresh Cycle	
				Normal	S-version
M5M467400Dxx	A0-A12	A0-A10	RAS Only Ref,Normal R/W	8192/64ms	8192/128ms
			CBR Ref,Hidden Ref	4096/64ms	4096/128ms
M5M465400Dxx	A0-A11	A0-A11	RAS Only Ref,Normal R/W CBR Ref,Hidden Ref	4096/64ms	4096/128ms
M5M467800Dxx	A0-A12	A0-A9	RAS Only Ref,Normal R/W	8192/64ms	8192/128ms
			CBR Ref,Hidden Ref	4096/64ms	4096/128ms
M5M465800Dxx	A0-A11	A0-A10	RAS Only Ref,Normal R/W CBR Ref,Hidden Ref	4096/64ms	4096/128ms
M5M465160Dxx	A0-A11	A0-A9	RAS Only Ref,Normal R/W CBR Ref,Hidden Ref	4096/64ms	4096/128ms

APPLICATION

Main memory unit for computers, Microcomputer memory, Refresh memory for CRT



M5M467400/465400DJ,DTP -5,-6,-5S,-6S

M5M467800/465800DJ,DTP -5,-6,-5S,-6S

M5M465160DJ,DTP -5,-6,-5S,-6S

FAST PAGE MODE 67108864-BIT (16777216-WORD BY 4-BIT) DYNAMIC RAM
 FAST PAGE MODE 67108864-BIT (8388608-WORD BY 8-BIT) DYNAMIC RAM
 FAST PAGE MODE 67108864-BIT (4194304-WORD BY 16-BIT) DYNAMIC RAM

PIN DESCRIPTION

M5M467400Dxx / M5M465400Dxx

Pin Name	Function
A0-A12	Address Inputs
DQ1-DQ4	Data Inputs / Outputs
RAS	Row Address Strobe Input
CAS	Column Address Strobe Input
\overline{W}	Write Control Input
\overline{OE}	Output Enable Input
Vcc	Power Supply (+3.3V)
Vss	Ground (0V)
NC	No Connection

M5M467800Dxx / M5M465800Dxx

Pin Name	Function
A0-A12	Address Inputs
DQ1-DQ8	Data Inputs / Outputs
RAS	Row Address Strobe Input
CAS	Column Address Strobe Input
\overline{W}	Write Control Input
\overline{OE}	Output Enable Input
Vcc	Power Supply (+3.3V)
Vss	Ground (0V)
NC	No Connection

M5M465160Dxx

Pin Name	Function
A0-A11	Address Inputs
DQ1-DQ16	Data Inputs / Outputs
RAS	Row Address Strobe Input
\overline{UCAS}	Upper byte control Column Address Strobe Input
\overline{LCAS}	Lower byte control Column Address Strobe Input
\overline{W}	Write Control Input
\overline{OE}	Output Enable Input
Vcc	Power Supply (+3.3V)
Vss	Ground (0V)
NC	No Connection

XX=J, TP

M5M467400/465400DJ, DTP PIN CONFIGURATION (TOP VIEW)

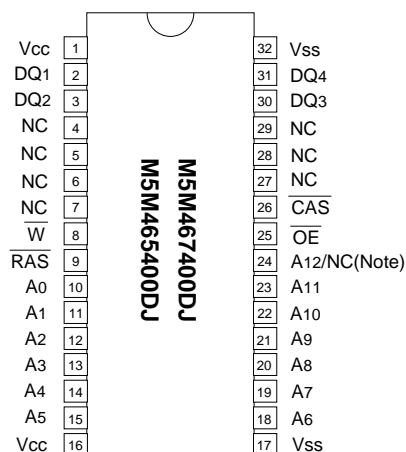

Outline 32P0N (400mil SOJ)

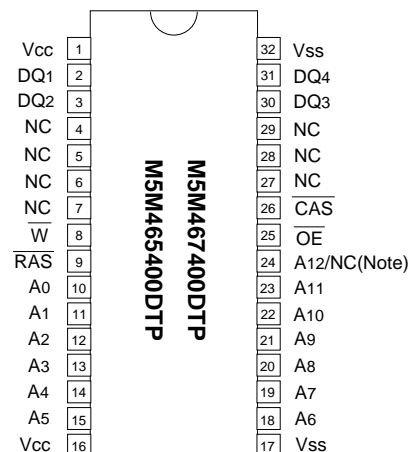

Outline 32P3N (400mil TSOP Normal Bend)

Note : A12...M5M467400Dxx, NC...M5M465400Dxx

NC : NO CONNECTION

M5M467400/465400DJ,DTP -5,-6,-5S,-6S M5M467800/465800DJ,DTP -5,-6,-5S,-6S M5M465160DJ,DTP -5,-6,-5S,-6S

FAST PAGE MODE 67108864-BIT (16777216-WORD BY 4-BIT) DYNAMIC RAM
FAST PAGE MODE 67108864-BIT (8388608-WORD BY 8-BIT) DYNAMIC RAM
FAST PAGE MODE 67108864-BIT (4194304-WORD BY 16-BIT) DYNAMIC RAM

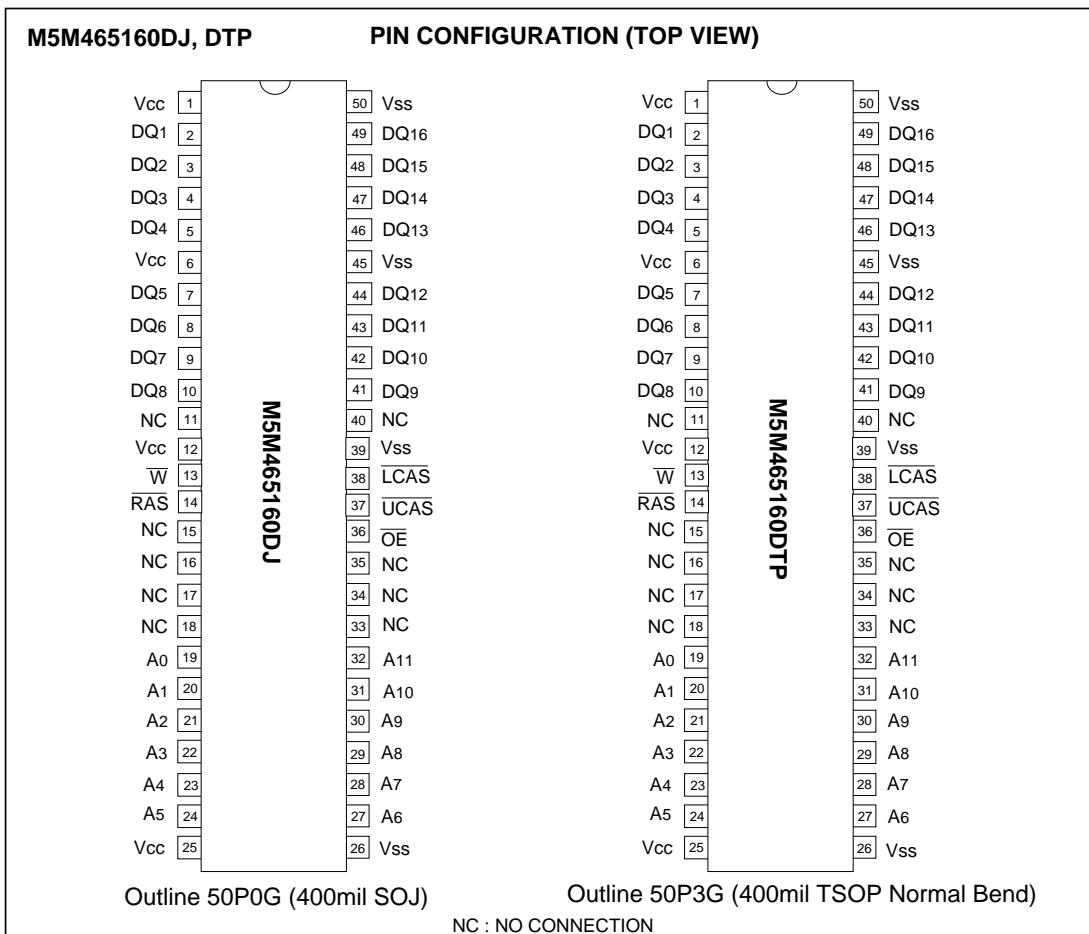
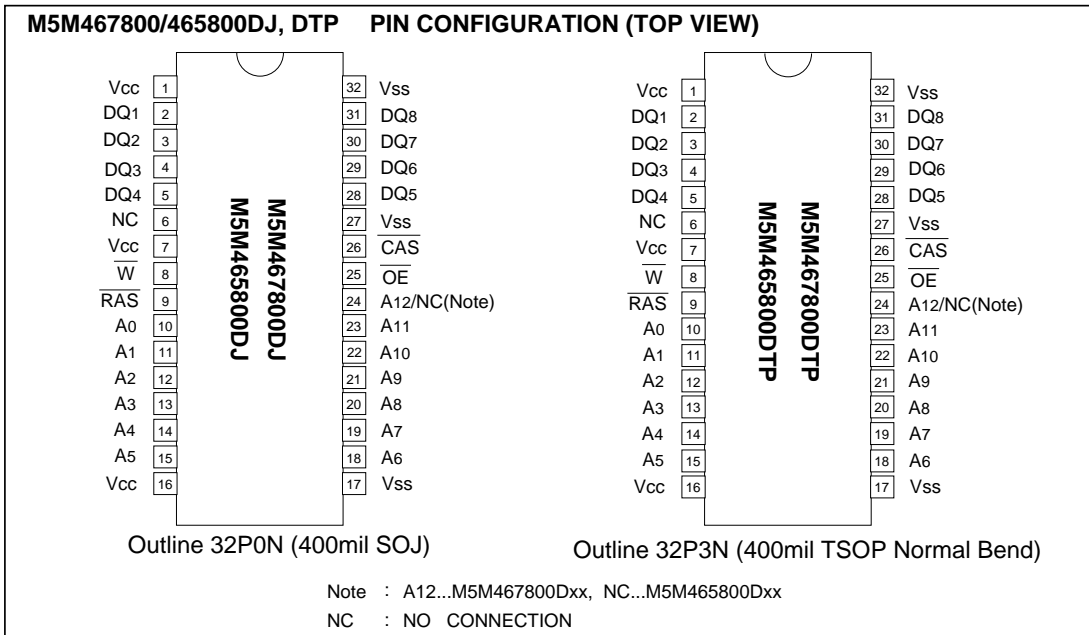

M5M467400/465400DJ,DTP -5,-6,-5S,-6S

M5M467800/465800DJ,DTP -5,-6,-5S,-6S

M5M465160DJ,DTP -5,-6,-5S,-6S

FAST PAGE MODE 67108864-BIT (16777216-WORD BY 4-BIT) DYNAMIC RAM
 FAST PAGE MODE 67108864-BIT (8388608-WORD BY 8-BIT) DYNAMIC RAM
 FAST PAGE MODE 67108864-BIT (4194304-WORD BY 16-BIT) DYNAMIC RAM

FUNCTION

The M5M467400(800)/465400(800,160)DJ, DTP provide, in addition to normal read, write, and read-modify-write operations, a number of other functions, e.g., fast page mode, CAS before RAS refresh, and delayed-write. The input conditions for each are shown in Table 1.

Table 1 Input conditions for each mode

M5M467400Dxx / M5M465400Dxx / M5M467800Dxx / M5M465800Dxx

Operation	Inputs						Input/Output		Refresh	Remark
	RAS	CAS	W	OE	Row address	Column address	Input	Output		
Read	ACT	ACT	NAC	ACT	APD	APD	OPN	VLD	NO	FAST PAGE mode identical
Write (Early write)	ACT	ACT	ACT	DNC	APD	APD	VLD	OPN	NO	
Write (Delayed write)	ACT	ACT	ACT	DNC	APD	APD	VLD	IVD	NO	
Read-modify-write	ACT	ACT	ACT	ACT	APD	APD	VLD	VLD	NO	
RAS-only refresh	ACT	NAC	DNC	DNC	APD	DNC	OPN	OPN	YES	
Hidden refresh	ACT	ACT	NAC	ACT	DNC	DNC	OPN	VLD	YES	
CAS before RAS refresh	ACT	ACT	NAC	DNC	DNC	DNC	DNC	OPN	YES	
Standby	NAC	DNC	DNC	DNC	DNC	DNC	DNC	OPN	NO	

M5M465160Dxx

Operation	Inputs						Input/Output		Refresh	Remark	
	RAS	LCAS	UCAS	W	OE	Row address	Column address	DQ1-DQ8			DQ9-DQ16
Lower byte read	ACT	ACT	NAC	NAC	ACT	APD	APD	VLD	OPN	NO	FAST PAGE mode identical
Upper byte read	ACT	NAC	ACT	NAC	ACT	APD	APD	OPN	VLD	NO	
Word read	ACT	ACT	ACT	NAC	ACT	APD	APD	VLD	VLD	NO	
Lower byte write	ACT	ACT	NAC	ACT	NAC	APD	APD	DIN	DNC	NO	
Upper byte write	ACT	NAC	ACT	ACT	NAC	APD	APD	DNC	DIN	NO	
Word write	ACT	ACT	ACT	ACT	NAC	APD	APD	DIN	DIN	NO	
RAS-only refresh	ACT	NAC	NAC	DNC	DNC	APD	DNC	OPN	OPN	YES	
Hidden refresh	ACT	ACT	ACT	NAC	ACT	DNC	DNC	VLD	VLD	YES	
CAS before RAS refresh	ACT	ACT	ACT	DNC	DNC	DNC	DNC	OPN	OPN	YES	
Stand-by	NAC	DNC	DNC	DNC	DNC	DNC	DNC	OPN	OPN	NO	

Note : ACT : active, NAC : nonactive, DNC : don't care, VLD : valid, IVD : Invalid, APD : applied, OPN : open

M5M467400/465400DJ,DTP -5,-6,-5S,-6S M5M467800/465800DJ,DTP -5,-6,-5S,-6S M5M465160DJ,DTP -5,-6,-5S,-6S

FAST PAGE MODE 67108864-BIT (16777216-WORD BY 4-BIT) DYNAMIC RAM
FAST PAGE MODE 67108864-BIT (8388608-WORD BY 8-BIT) DYNAMIC RAM
FAST PAGE MODE 67108864-BIT (4194304-WORD BY 16-BIT) DYNAMIC RAM

M5M467400Dxx / M5M465400Dxx

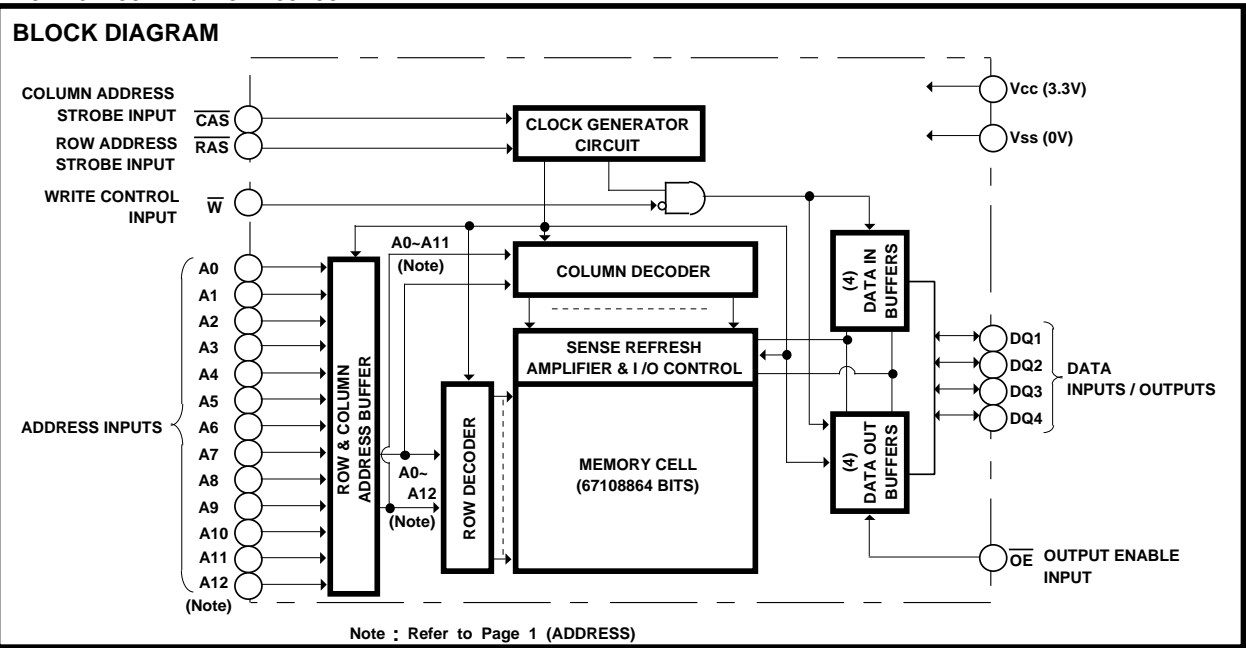

M5M467800Dxx / M5M465800Dxx

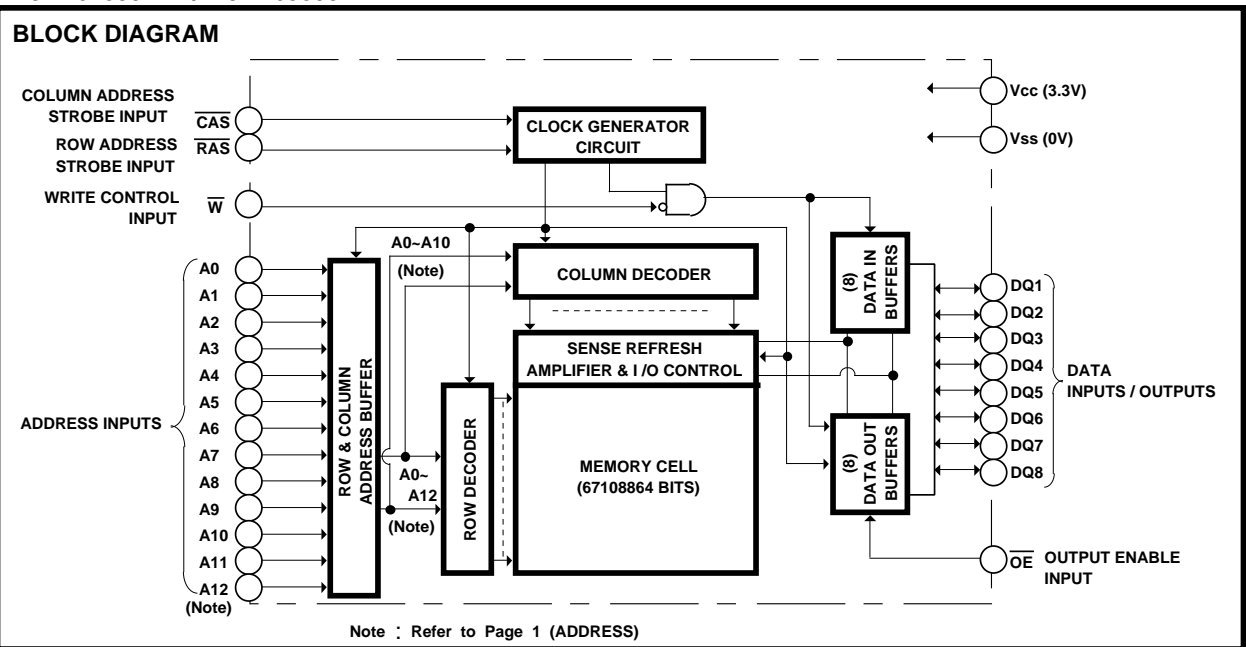

M5M467400/465400DJ,DTP -5,-6,-5S,-6S M5M467800/465800DJ,DTP -5,-6,-5S,-6S M5M465160DJ,DTP -5,-6,-5S,-6S

FAST PAGE MODE 67108864-BIT (16777216-WORD BY 4-BIT) DYNAMIC RAM
FAST PAGE MODE 67108864-BIT (8388608-WORD BY 8-BIT) DYNAMIC RAM
FAST PAGE MODE 67108864-BIT (4194304-WORD BY 16-BIT) DYNAMIC RAM

M5M465160Dxx

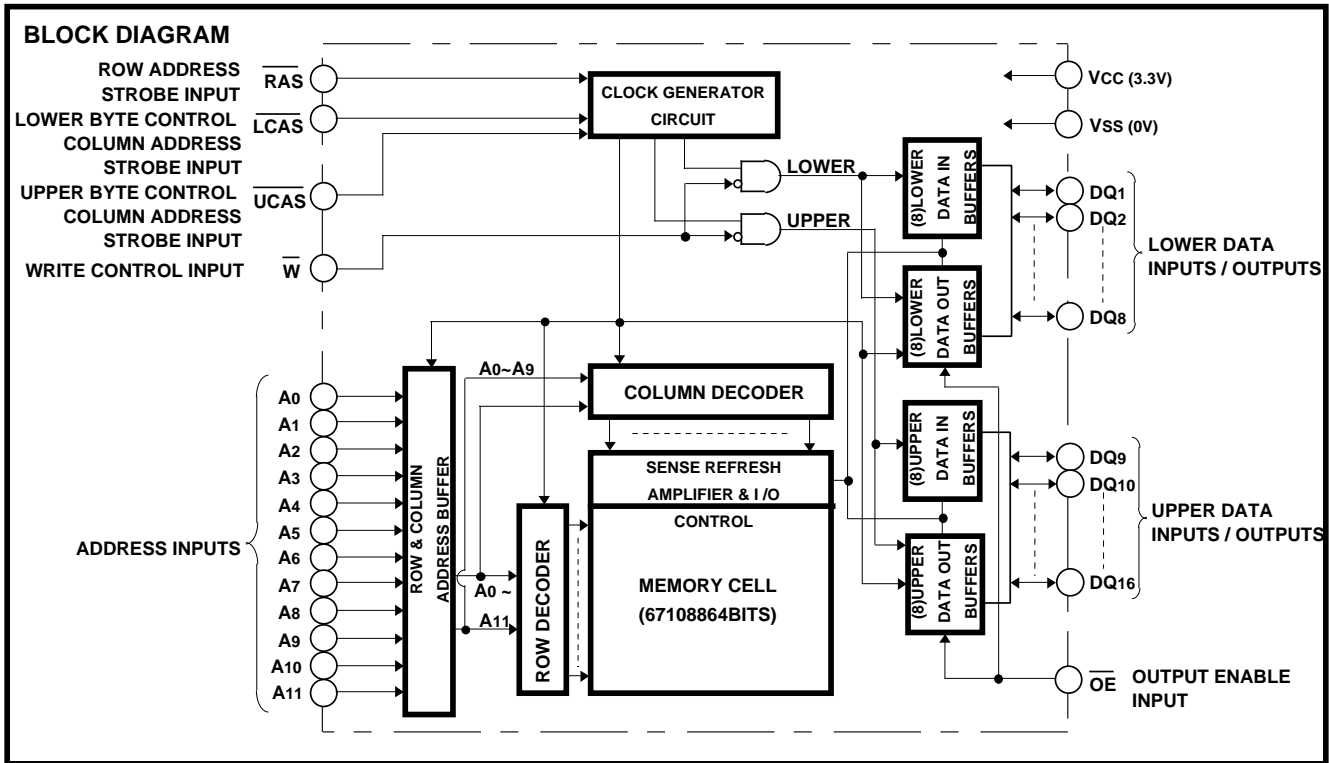

M5M467400/465400DJ,DTP -5,-6,-5S,-6S

M5M467800/465800DJ,DTP -5,-6,-5S,-6S

M5M465160DJ,DTP -5,-6,-5S,-6S

FAST PAGE MODE 67108864-BIT (16777216-WORD BY 4-BIT) DYNAMIC RAM
 FAST PAGE MODE 67108864-BIT (8388608-WORD BY 8-BIT) DYNAMIC RAM
 FAST PAGE MODE 67108864-BIT (4194304-WORD BY 16-BIT) DYNAMIC RAM

ABSOLUTE MAXIMUM RATINGS

Symbol	Parameter	Conditions	Ratings	Unit
V _{CC}	Supply voltage	With respect to V _{SS}	-0.5 ~ 4.6	V
V _I	Input voltage		-0.5 ~ 4.6	V
V _O	Output voltage		-0.5 ~ 4.6	V
I _O	Output current		50	mA
P _d	Power dissipation	T _a =25°C	1000	mW
Topr	Operating temperature		0 ~ 70	°C
Tstg	Storage temperature		-65 ~ 150	°C

RECOMMENDED OPERATING CONDITIONS (T_a=0 ~ 70°C, unless otherwise noted) (Note 1)

Symbol	Parameter	Limits			Unit
		Min	Nom	Max	
V _{CC}	Supply voltage	3.0	3.3	3.6	V
V _{SS}	Supply voltage	0	0	0	V
V _{IH}	High-level input voltage, all inputs	2.0		V _{CC} +0.3	V
V _{IL}	Low-level input voltage, all inputs	-0.3		0.8	V

Note 1 : All voltage values are with respect to V_{SS}.

ELECTRICAL CHARACTERISTICS (T_a=0 ~ 70°C, V_{CC}=3.3 ± 0.3V, V_{SS}=0V, unless otherwise noted) (Note 2)

[M5M467400D / M5M467800D]

Symbol	Parameter	Test conditions	Limits			Unit
			Min	Typ	Max	
V _{OH}	High-level output voltage	I _{OH} =-2mA	2.4		V _{CC}	V
V _{OL}	Low-level output voltage	I _{OL} =2mA	0		0.4	V
I _{OZ}	Off-state output current	Q floating 0V V _{OUT} V _{CC}	-10		10	μA
I _I	Input current	0V V _{IN} V _{CC} +0.3V, Other input pins=0V	-10		10	μA
I _{CC1} (AV)	Average supply current from V _{CC} operating (Note 3,4,5)	M5M467400D-5,5S M5M467800D-5,5S	RAS, CAS cycling t _{RC} =t _{WC} =min. output open		100	mA
		M5M467400D-6,6S M5M467800D-6,6S			90	
		M5M467400D-5,5S -6,6S M5M467800D-5,5S -6,6S	RAS= CAS =V _{IH} , output open		1	
I _{CC2} (AV)	Average supply current from V _{CC} stand-by (Note 6)	M5M467400D-5,5S -6,6S M5M467800D-5,5S -6,6S			0.5	mA
		M5M467400D-5,6 M5M467800D-5,6	RAS= CAS V _{CC} -0.2V, output open		0.3	
		M5M467400D-5S,6S M5M467800D-5S,6S				
I _{CC4} (AV)	Average supply current from V _{CC} Fast-Page-Mode (Note 3,4,5)	M5M467400D-5,5S M5M467800D-5,5S	RAS=V _{IL} , CAS cycling t _{PC} =min. output open		100	mA
		M5M467400D-6,6S M5M467800D-6,6S			90	
		M5M467400D-5,5S M5M467800D-5,5S	CAS before RAS refresh cycling t _{RC} =min. output open		130	
I _{CC6} (AV)	Average supply current from V _{CC} CAS before RAS refresh mode (Note 3,5)	M5M467400D-5,5S M5M467800D-5,5S			120	mA
		M5M467400D-6,6S M5M467800D-6,6S				

Note 2: Current flowing into an IC is positive, out is negative.

3: I_{CC1} (AV), I_{CC4} (AV) and I_{CC6} (AV) are dependent on cycle rate. Maximum current is measured at the fastest cycle rate.

4: I_{CC1} (AV) and I_{CC4} (AV) are dependent on output loading. Specified values are obtained with the output open.

5: Column Address can be changed once or less while RAS=V_{IL} and CAS=V_{IH}.

M5M467400/465400DJ,DTP -5,-6,-5S,-6S

M5M467800/465800DJ,DTP -5,-6,-5S,-6S

M5M465160DJ,DTP -5,-6,-5S,-6S

FAST PAGE MODE 67108864-BIT (16777216-WORD BY 4-BIT) DYNAMIC RAM
 FAST PAGE MODE 67108864-BIT (8388608-WORD BY 8-BIT) DYNAMIC RAM
 FAST PAGE MODE 67108864-BIT (4194304-WORD BY 16-BIT) DYNAMIC RAM

ELECTRICAL CHARACTERISTICS (Ta=0 ~ 70°C, Vcc=3.3 ± 0.3V, Vss=0V, unless otherwise noted) (Note 2)

[M5M465400D / M5M465800D]

Symbol	Parameter	Test conditions	Limits			Unit
			Min	Typ	Max	
V _{OH}	High-level output voltage	I _{OH} =-2mA	2.4		V _{CC}	V
V _{OL}	Low-level output voltage	I _{OL} =2mA	0		0.4	V
I _{OZ}	Off-state output current	Q floating 0V V _{OUT} V _{CC}	-10		10	μA
I _I	Input current	0V V _{IN} V _{CC} +0.3V, Other input pins=0V	-10		10	μA
I _{CC1} (AV)	Average supply current from V _{CC} operating (Note 3,4,5)	M5M465400D-5,5S M5M465800D-5,5S	R _{AS} , C _{AS} cycling tr _{CC} =tw _C =min. output open		130	mA
		M5M465400D-6,6S M5M465800D-6,6S			120	
I _{CC2} (AV)	Average supply current from V _{CC} stand-by (Note 6)	M5M465400D-5,5S -6,6S M5M465800D-5,5S -6,6S	R _{AS} = C _{AS} =V _{IH} , output open		1	mA
		M5M465400D-5,6 M5M465800D-5,6	R _{AS} = C _{AS} V _{CC} -0.2V, output open		0.5	
		M5M465400D-5S,6S M5M465800D-5S,6S			0.3	
I _{CC4} (AV)	Average supply current from V _{CC} Fast-Page-Mode (Note 3,4,5)	M5M465400D-5,5S M5M465800D-5,5S	R _{AS} =V _{IL} , C _{AS} cycling tp _C =min. output open		100	mA
		M5M465400D-6,6S M5M465800D-6,6S			90	
I _{CC6} (AV)	Average supply current from V _{CC} C _{AS} before R _{AS} refresh mode (Note 3,5)	M5M465400D-5,5S M5M465800D-5,5S	C _{AS} before R _{AS} refresh cycling tr _{CC} =min. output open		130	mA
		M5M465400D-6,6S M5M465800D-6,6S			120	

[M5M465160D]

Symbol	Parameter	Test conditions	Limits			Unit
			Min	Typ	Max	
V _{OH}	High-level output voltage	I _{OH} =-2mA	2.4		V _{CC}	V
V _{OL}	Low-level output voltage	I _{OL} =2mA	0		0.4	V
I _{OZ}	Off-state output current	Q floating 0V V _{OUT} V _{CC}	-10		10	μA
I _I	Input current	0V V _{IN} V _{CC} +0.3V, Other input pins=0V	-10		10	μA
I _{CC1} (AV)	Average supply current from V _{CC} operating (Note 3,4,5)	M5M465160D-5,5S M5M465160D-6,6S	R _{AS} , C _{AS} cycling tr _{CC} =tw _C =min. output open		140	mA
					130	
I _{CC2} (AV)	Average supply current from V _{CC} stand-by (Note 6)	M5M465160D-5,5S -6,6S	R _{AS} = C _{AS} =V _{IH} , output open		1	mA
		M5M465160D-5,6 M5M465160D-5S,6S	R _{AS} = C _{AS} V _{CC} -0.2V, output open		0.5	
					0.3	
I _{CC4} (AV)	Average supply current from V _{CC} Fast-Page-Mode (Note 3,4,5)	M5M465160D-5,5S M5M465160D-6,6S	R _{AS} =V _{IL} , C _{AS} cycling tp _C =min. output open		105	mA
					95	
I _{CC6} (AV)	Average supply current from V _{CC} C _{AS} before R _{AS} refresh mode (Note 3,5)	M5M465160D-5,5S M5M465160D-6,6S	C _{AS} before R _{AS} refresh cycling tr _{CC} =min. output open		140	mA
					130	

M5M467400/465400DJ,DTP -5,-6,-5S,-6S

M5M467800/465800DJ,DTP -5,-6,-5S,-6S

M5M465160DJ,DTP -5,-6,-5S,-6S

FAST PAGE MODE 67108864-BIT (16777216-WORD BY 4-BIT) DYNAMIC RAM
 FAST PAGE MODE 67108864-BIT (8388608-WORD BY 8-BIT) DYNAMIC RAM
 FAST PAGE MODE 67108864-BIT (4194304-WORD BY 16-BIT) DYNAMIC RAM

CAPACITANCE (Ta=0 ~ 70°C, Vcc=3.3 ± 0.3V, Vss=0V, unless otherwise noted)

Symbol	Parameter	Test conditions	Limits			Unit
			Min	Typ	Max	
C _{I(A)}	Input capacitance, address inputs	Vi=Vss f=1MHz Vi=25mVrms			5	pF
C _{I(OE)}	Input capacitance, OE input				7	pF
C _{I(W)}	Input capacitance, write control input				7	pF
C _{I(RAS)}	Input capacitance, RAS input				7	pF
C _{I(CAS)}	Input capacitance, CAS input				7	pF
C _{I/O}	Input/Output capacitance, data ports				7	pF

SWITCHING CHARACTERISTICS (Ta=0 ~ 70°C, Vcc=3.3 ± 0.3V, Vss=0V, unless otherwise noted, see notes 6,13,14)

Symbol	Parameter	Limits				Unit
		M5M46X400D-5,5S		M5M46X400D-6,6S		
		Min	Max	Min	Max	
t _{CAC}	Access time from CAS (Note 7,8)		13		15	ns
t _{RAC}	Access time from RAS (Note 7,9)		50		60	ns
t _{AA}	Column address access time (Note 7,10)		25		30	ns
t _{CPA}	Access time from CAS precharge (Note 7,11)		30		35	ns
t _{OE}	Access time from OE (Note 7)		13		15	ns
t _{CLZ}	Output low impedance time from CAS low (Note 7)	5		5		ns
t _{OFF}	Output disable time after CAS high (Note 12)	0	13	0	15	ns
t _{OEZ}	Output disable time after OE high (Note 12)	0	13	0	15	ns

Note 6: An initial pause of 500μs is required after power-up followed by a minimum of eight initialization cycles (any combination of cycles containing RAS-only refresh or CAS before RAS refresh).

Note the RAS may be cycled during the initial pause. And any eight initialization cycles are required after prolonged periods (greater than 64 ms) of RAS inactivity before proper device operation is achieved.

7: Measured with a load circuit equivalent to V_{OH}=2.4V(I_{OH}=-2mA) / V_{OL}=0.4V(I_{OL}=2mA) loads and 100pF. The reference levels for measuring of output signals are V_{OH}=2.0V and V_{OL}=0.8V.

8: Assumes that t_{RCD} t_{RCD(max)} and t_{ASC} t_{ASC(max)} and t_{CP} t_{CP(max)}.

9: Assumes that t_{RCD} t_{RCD(max)} and t_{RAD} t_{RAD(max)}. If t_{RCD} or t_{RAD} is greater than the maximum recommended value shown in this table, t_{RAC} will increase by amount that t_{RCD} exceeds the value shown.

10: Assumes that t_{RAD} t_{RAD(max)} and t_{ASC} t_{ASC(max)}.

11: Assumes that t_{CP} t_{CP(max)} and t_{ASC} t_{ASC(max)}.

12: t_{OFF(max)} and t_{OEZ(max)} defines the time at which the output achieves the high impedance state (I_{out} ± 10 μA) and is not reference to V_{OH(min)} or V_{OL(max)}.

M5M467400/465400DJ,DTP -5,-6,-5S,-6S

M5M467800/465800DJ,DTP -5,-6,-5S,-6S

M5M465160DJ,DTP -5,-6,-5S,-6S

FAST PAGE MODE 67108864-BIT (16777216-WORD BY 4-BIT) DYNAMIC RAM
 FAST PAGE MODE 67108864-BIT (8388608-WORD BY 8-BIT) DYNAMIC RAM
 FAST PAGE MODE 67108864-BIT (4194304-WORD BY 16-BIT) DYNAMIC RAM

TIMING REQUIREMENTS (For Read, Write, Read-Modify-Write ,Refresh, and Fast-Page Mode Cycles)

(Ta=0 ~ 70°C, Vcc=3.3 ±0.3V, Vss=0V, unless otherwise noted See notes 13,14)

Symbol	Parameter	Limits				Unit
		M5M46X400D-5,5S		M5M46X400D-6,6S		
		M5M46X800D-5,5S		M5M46X800D-6,6S		
		M5M465160D-5,5S		M5M465160D-6,6S		
		Min	Max	Min	Max	
tREF	Refresh cycle time		64		64	ms
tREF	Refresh cycle time (S-version only)		128		128	ms
trP	RAS high pulse width	30		40		ns
trCD	Delay time, RAS low to CAS low (Note15)	18	37	20	45	ns
tCRP	Delay time, CAS high to RAS low	5		10		ns
trPC	Delay time, RAS high to CAS low	0		0		ns
tCPN	CAS high pulse width	8		10		ns
tRAD	Column address delay time from RAS low (Note16)	13	25	15	30	ns
tASR	Row address setup time before RAS low	0		0		ns
tASC	Column address setup time before CAS low (Note17)	0	7	0	10	ns
tRAH	Row address hold time after RAS low	8		10		ns
tCAH	Column address hold time after CAS low	13		15		ns
tdZC	Delay time, data to CAS low (Note18)	0		0		ns
tdZO	Delay time, data to OE low (Note18)	0		0		ns
tcDD	Delay time, CAS high to data (Note19)	13		15		ns
tODD	Delay time, OE high to data (Note19)	13		15		ns
tT	Transition time (Note20)	1	50	1	50	ns

Note 13: The timing requirements are assumed $t_T = 5ns$.

14: $V_{IH(min)}$ and $V_{IL(max)}$ are reference levels for measuring timing of input signals. $V_{IH(min)}$ and $V_{IL(max)}$ of the switching characteristics are 2.0V and 0.8V respectively.

15: $t_{rCD(max)}$ is specified as a reference point only. If t_{rCD} is less than $t_{rCD(max)}$, access time is t_{rAC} . If t_{rCD} is greater than $t_{rCD(max)}$, access time is controlled exclusively by t_{CAC} or t_{AA} . $t_{rCD(min)}$ is specified as $t_{rCD(min)} = t_{rAH(min)} + 2t_T + t_{ASC(min)}$.

16: $t_{rAD(max)}$ is specified as a reference point only. If t_{rAD} , $t_{rAD(max)}$ and t_{ASC} , $t_{ASC(max)}$, access time is controlled exclusively by t_{AA} .

17: $t_{ASC(max)}$ is specified as a reference point only. If t_{rCD} , $t_{rCD(max)}$ and t_{ASC} , $t_{ASC(max)}$, access time is controlled exclusively by t_{CAC} .

18: Either t_{dZC} or t_{dZO} must be satisfied.

19: Either t_{cDD} or t_{ODD} must be satisfied.

20: t_T is measured between $V_{IH(min)}$ and $V_{IL(max)}$.

Read and Refresh Cycles

Symbol	Parameter	Limits				Unit
		M5M46X400D-5,5S		M5M46X400D-6,6S		
		M5M46X800D-5,5S		M5M46X800D-6,6S		
		M5M465160D-5,5S		M5M465160D-6,6S		
		Min	Max	Min	Max	
tRC	Read cycle time	90		110		ns
tRAS	RAS low pulse width	50	10000	60	10000	ns
tCAS	CAS low pulse width	13	10000	15	10000	ns
tCSH	CAS hold time after RAS low	50		60		ns
tRSH	RAS hold time after CAS low	13		15		ns
tRCS	Read Setup time before CAS low	0		0		ns
tRCH	Read hold time after CAS high (Note 21)	0		0		ns
tRRH	Read hold time after RAS high (Note 21)	10		10		ns
tRAL	Column address to RAS hold time	25		30		ns
toCH	CAS hold time after OE low	13		15		ns
toRH	RAS hold time after OE low	13		15		ns

Note 21: Either t_{RCH} or t_{RRH} must be satisfied for a read cycle.

M5M467400/465400DJ,DTP -5,-6,-5S,-6S

M5M467800/465800DJ,DTP -5,-6,-5S,-6S

M5M465160DJ,DTP -5,-6,-5S,-6S

FAST PAGE MODE 67108864-BIT (16777216-WORD BY 4-BIT) DYNAMIC RAM
 FAST PAGE MODE 67108864-BIT (8388608-WORD BY 8-BIT) DYNAMIC RAM
 FAST PAGE MODE 67108864-BIT (4194304-WORD BY 16-BIT) DYNAMIC RAM

Write Cycle (Early Write and Delayed Write)

Symbol	Parameter	Limits				Unit
		M5M46X400D-5,5S		M5M46X400D-6,6S		
		Min	Max	Min	Max	
t _{WC}	Write cycle time	90		110		ns
t _{RAS}	$\overline{\text{RAS}}$ low pulse width	50	10000	60	10000	ns
t _{CAS}	$\overline{\text{CAS}}$ low pulse width	13	10000	15	10000	ns
t _{CSH}	$\overline{\text{CAS}}$ hold time after $\overline{\text{RAS}}$ low	50		60		ns
t _{RSH}	$\overline{\text{RAS}}$ hold time after $\overline{\text{CAS}}$ low	13		15		ns
t _{WCS}	Write setup time before $\overline{\text{CAS}}$ low (Note 23)	0		0		ns
t _{WCH}	Write hold time after $\overline{\text{CAS}}$ low	8		10		ns
t _{CWL}	$\overline{\text{CAS}}$ hold time after $\overline{\text{W}}$ low	13		15		ns
t _{RWL}	$\overline{\text{RAS}}$ hold time after $\overline{\text{W}}$ low	13		15		ns
t _{WP}	Write pulse width	8		10		ns
t _{DS}	Data setup time before $\overline{\text{CAS}}$ low or $\overline{\text{W}}$ low	0		0		ns
t _{DH}	Data hold time after $\overline{\text{CAS}}$ low or $\overline{\text{W}}$ low	8		10		ns
t _{OE}	$\overline{\text{OE}}$ hold time after $\overline{\text{W}}$ low	13		15		ns

Read-Write and Read-Modify-Write Cycles

Symbol	Parameter	Limits				Unit
		M5M46X400D-5,5S		M5M46X400D-6,6S		
		Min	Max	Min	Max	
t _{RWC}	Read write/read modify write cycle time (Note22)	126		150		ns
t _{RAS}	$\overline{\text{RAS}}$ low pulse width	85	10000	95	10000	ns
t _{CAS}	$\overline{\text{CAS}}$ low pulse width	50	10000	50	10000	ns
t _{CSH}	$\overline{\text{CAS}}$ hold time after $\overline{\text{RAS}}$ low	85		95		ns
t _{RSH}	$\overline{\text{RAS}}$ hold time after $\overline{\text{CAS}}$ low	50		50		ns
t _{RCS}	Read setup time before $\overline{\text{CAS}}$ low	0		0		ns
t _{CWD}	Delay time, $\overline{\text{CAS}}$ low to $\overline{\text{W}}$ low (Note23)	30		30		ns
t _{RWD}	Delay time, $\overline{\text{RAS}}$ low to $\overline{\text{W}}$ low (Note23)	65		75		ns
t _{AWD}	Delay time, address to $\overline{\text{W}}$ low (Note23)	40		45		ns
t _{CWL}	$\overline{\text{CAS}}$ hold time after $\overline{\text{W}}$ low	13		15		ns
t _{RWL}	$\overline{\text{RAS}}$ hold time after $\overline{\text{W}}$ low	13		15		ns
t _{WP}	Write pulse width	8		10		ns
t _{DS}	Data setup time before $\overline{\text{CAS}}$ low or $\overline{\text{W}}$ low	0		0		ns
t _{DH}	Data hold time after $\overline{\text{CAS}}$ low or $\overline{\text{W}}$ low	8		10		ns
t _{OE}	$\overline{\text{OE}}$ hold time after $\overline{\text{W}}$ low	13		15		ns

Note 22: t_{RWC} is specified as t_{RWC}(min)=t_{RAC}(max)+t_{ODD}(min)+t_{RWL}(min)+t_{RP}(min)+4t.

23: t_{WCS}, t_{CWD}, t_{RWD} and t_{AWD} and, t_{CPWD} are specified as reference points only. If t_{WCS} t_{WCS}(min) the cycle is an early write cycle and the DQ pins will remain high impedance throughout the entire cycle. If t_{CWD} t_{CWD}(min), t_{RWD} t_{RWD}(min), t_{AWD} t_{AWD}(min) and t_{CPWD} t_{CPWD}(min) (for Fast Page mode cycle only), the cycle is a read-modify-write cycle and the DQ will contain the data read from the selected address. If neither of the above condition (delayed write) is satisfied, the DQ (at access time and until $\overline{\text{CAS}}$ or $\overline{\text{OE}}$ goes back to V_H) is indeterminate.

M5M467400/465400DJ,DTP -5,-6,-5S,-6S

M5M467800/465800DJ,DTP -5,-6,-5S,-6S

M5M465160DJ,DTP -5,-6,-5S,-6S

FAST PAGE MODE 67108864-BIT (16777216-WORD BY 4-BIT) DYNAMIC RAM
 FAST PAGE MODE 67108864-BIT (8388608-WORD BY 8-BIT) DYNAMIC RAM
 FAST PAGE MODE 67108864-BIT (4194304-WORD BY 16-BIT) DYNAMIC RAM

Fast-Page Mode Cycle (Read, Early Write, Read-Write, Read-Modify-Write Cycle) (Note 24)

Symbol	Parameter	Limits				Unit
		M5M46X400D-5,5S		M5M46X400D-6,6S		
		Min	Max	Min	Max	
tPC	Fast page mode read/write cycle time	35		40		ns
tPRWC	Fast page mode read write/read modify write cycle time	70		75		ns
tRAS	RAS low pulse width for read write cycle (Note25)	85	125000	100	125000	ns
tCP	CAS high pulse width (Note26)	8	12	10	15	ns
tCPRH	RAS hold time after CAS precharge	30		35		ns
tCPWD	Delay time, CAS precharge to W low (Note23)	30		35		ns

Note 24: All previously specified timing requirements and switching characteristics are applicable to their respective Fast page mode cycle.

25: tRAS(min) is specified as two cycles of CAS input are performed.

26: tCP(max) is specified as a reference point only. If tCP < tCP(max), access time is controlled exclusively by tCAC.

CAS before RAS Refresh Cycle (Note 27)

Symbol	Parameter	Limits				Unit
		M5M46X400D-5,5S		M5M46X400D-6,6S		
		Min	Max	Min	Max	
tCSR	CAS setup time before RAS low	5		5		ns
tCHR	CAS hold time after RAS low	10		10		ns
tRSR	Read setup time before RAS low	10		10		ns
tRHR	Read hold time after RAS low	10		10		ns

Note 27: Eight or more CAS before RAS cycles instead of eight RAS cycles are necessary for proper operation of CAS before RAS refresh mode.

M5M467400/465400DJ,DTP -5,-6,-5S,-6S

M5M467800/465800DJ,DTP -5,-6,-5S,-6S

M5M465160DJ,DTP -5,-6,-5S,-6S

FAST PAGE MODE 67108864-BIT (16777216-WORD BY 4-BIT) DYNAMIC RAM
 FAST PAGE MODE 67108864-BIT (8388608-WORD BY 8-BIT) DYNAMIC RAM
 FAST PAGE MODE 67108864-BIT (4194304-WORD BY 16-BIT) DYNAMIC RAM

SELF REFRESH SPECIFICATIONS

Self refresh devices are denoted by "S" after speed item, like -5S / -6S . The other characteristics and requirements than the below are same as normal devices.

ELECTRICAL CHARACTERISTICS (Ta=0 ~ 70°C, Vcc=3.3V ± 0.3V, Vss=0V, unless otherwise noted) (Note 2)

Symbol	Parameter	Test conditions	Limits			Unit
			Min	Typ	Max	
I _{CC8} (AV)	Average supply current from V _{CC} Extended - Refresh cycle (note 5,6)	M5M46X400D-5S,6S M5M46X800D-5S,6S M5M465160D-5S,6S CAS before RAS refresh cycling input high level V _{CC} -0.2V input low level 0.2V output = OPEN, t _{RC} = 31.25μs t _{RAS} = t _{RAS} (min) ~ 300ns			500	μA
I _{CC9} (AV)	Average supply current from V _{CC} Self - Refresh cycle (note 6)	M5M46X400D-5S,6S M5M46X800D-5S,6S M5M465160D-5S,6S RAS = CAS 0.2V output = OPEN			400	μA

TIMING REQUIREMENTS (Ta=0 ~ 70°C, Vcc=3.3V ± 0.3V, Vss=0V, unless otherwise noted See notes 13,14)

Symbol	Parameter	Limits				Unit
		M5M46X400D-5S		M5M46X400D-6S		
		Min	Max	Min	Max	
t _{RASS}	Self Refresh RAS low pulse width	100		100		μs
t _{RPS}	Self Refresh RAS high precharge time	90		110		ns
t _{CHS}	Self Refresh CAS hold time	- 50		- 50		ns

SELF REFRESH ENTRY & EXIT CONDITIONS

(1) In case of CBR distributed refresh

The last / first full refresh cycles must be made within t_{NS} / t_{SN} before / after self refresh , on the condition of t_{NS} 128 ms and t_{SN} 128 ms.

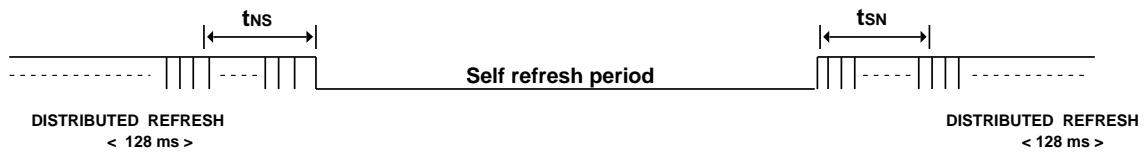

(2) In case of burst refresh

The last / first full refresh cycles must be made within t_{NS} / t_{SN} before / after self refresh , on the condition of t_{NS} 16 ms and t_{SN} 16 ms.

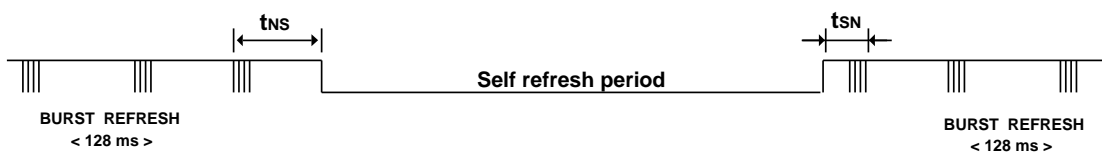

M5M467400/465400DJ,DTP -5,-6,-5S,-6S M5M467800/465800DJ,DTP -5,-6,-5S,-6S M5M465160DJ,DTP -5,-6,-5S,-6S

FAST PAGE MODE 67108864-BIT (1677216-WORD BY 4-BIT) DYNAMIC RAM
FAST PAGE MODE 67108864-BIT (8388608-WORD BY 8-BIT) DYNAMIC RAM
FAST PAGE MODE 67108864-BIT (4194304-WORD BY 16-BIT) DYNAMIC RAM

Timing Diagrams (Note 28)

Read Cycle

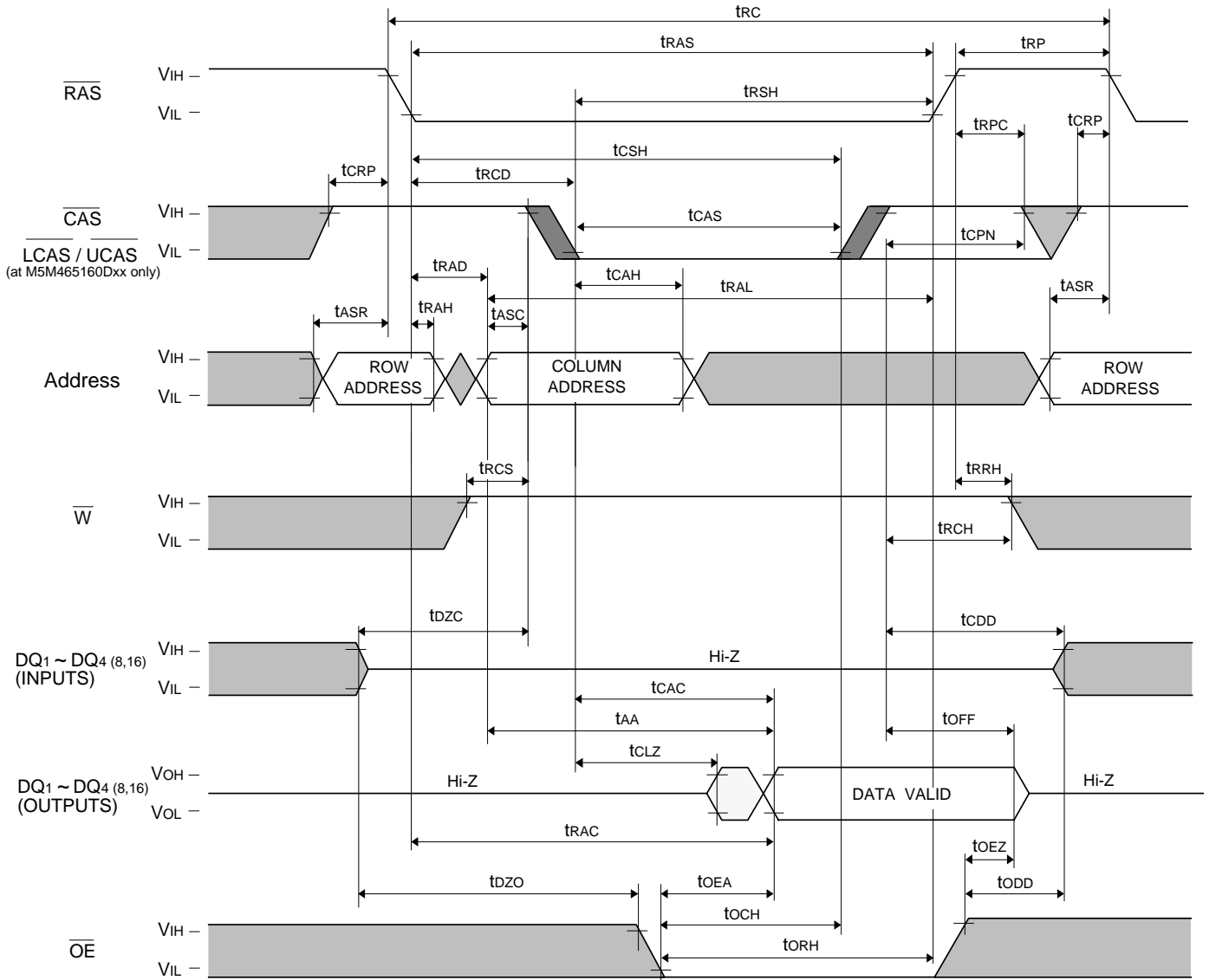

Note 28:



Indicates the don't care input.
 $V_{\text{IH}}(\text{min})$ V_{IN} $V_{\text{IH}}(\text{max})$ or $V_{\text{IL}}(\text{min})$ V_{IN} $V_{\text{IL}}(\text{max})$



Indicates the invalid output.



Indicates the skew of the two inputs. (at M5M465160xx only)



M5M467400/465400DJ,DTP -5,-6,-5S,-6S M5M467800/465800DJ,DTP -5,-6,-5S,-6S M5M465160DJ,DTP -5,-6,-5S,-6S

FAST PAGE MODE 67108864-BIT (1677216-WORD BY 4-BIT) DYNAMIC RAM
FAST PAGE MODE 67108864-BIT (8388608-WORD BY 8-BIT) DYNAMIC RAM
FAST PAGE MODE 67108864-BIT (4194304-WORD BY 16-BIT) DYNAMIC RAM

Fast Page Mode Read Cycle

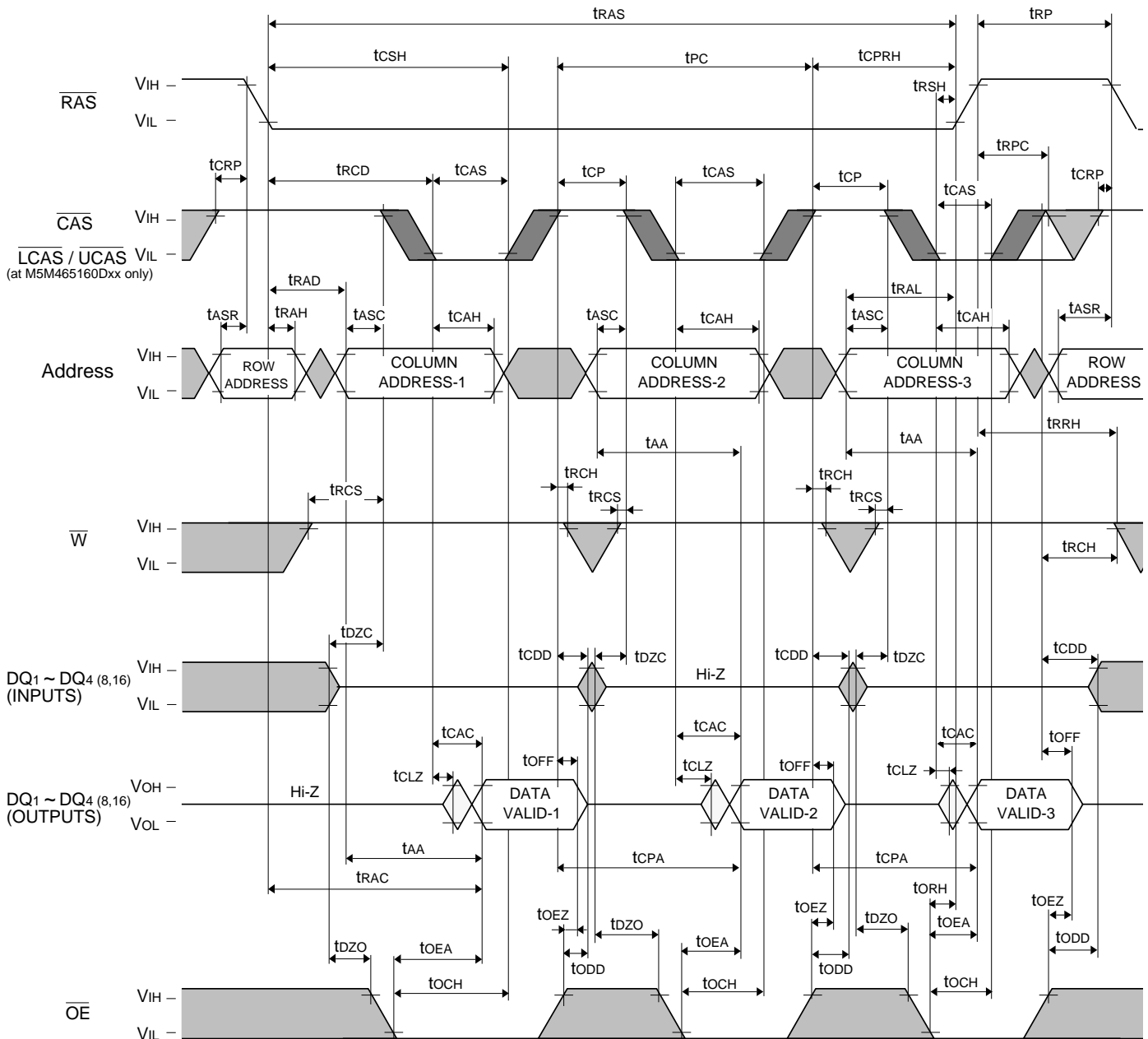

M5M467400/465400DJ,DTP -5,-6,-5S,-6S M5M467800/465800DJ,DTP -5,-6,-5S,-6S M5M465160DJ,DTP -5,-6,-5S,-6S

FAST PAGE MODE 67108864-BIT (1677216-WORD BY 4-BIT) DYNAMIC RAM
FAST PAGE MODE 67108864-BIT (8388608-WORD BY 8-BIT) DYNAMIC RAM
FAST PAGE MODE 67108864-BIT (4194304-WORD BY 16-BIT) DYNAMIC RAM

Fast Page Mode Write Cycle (Early Write)

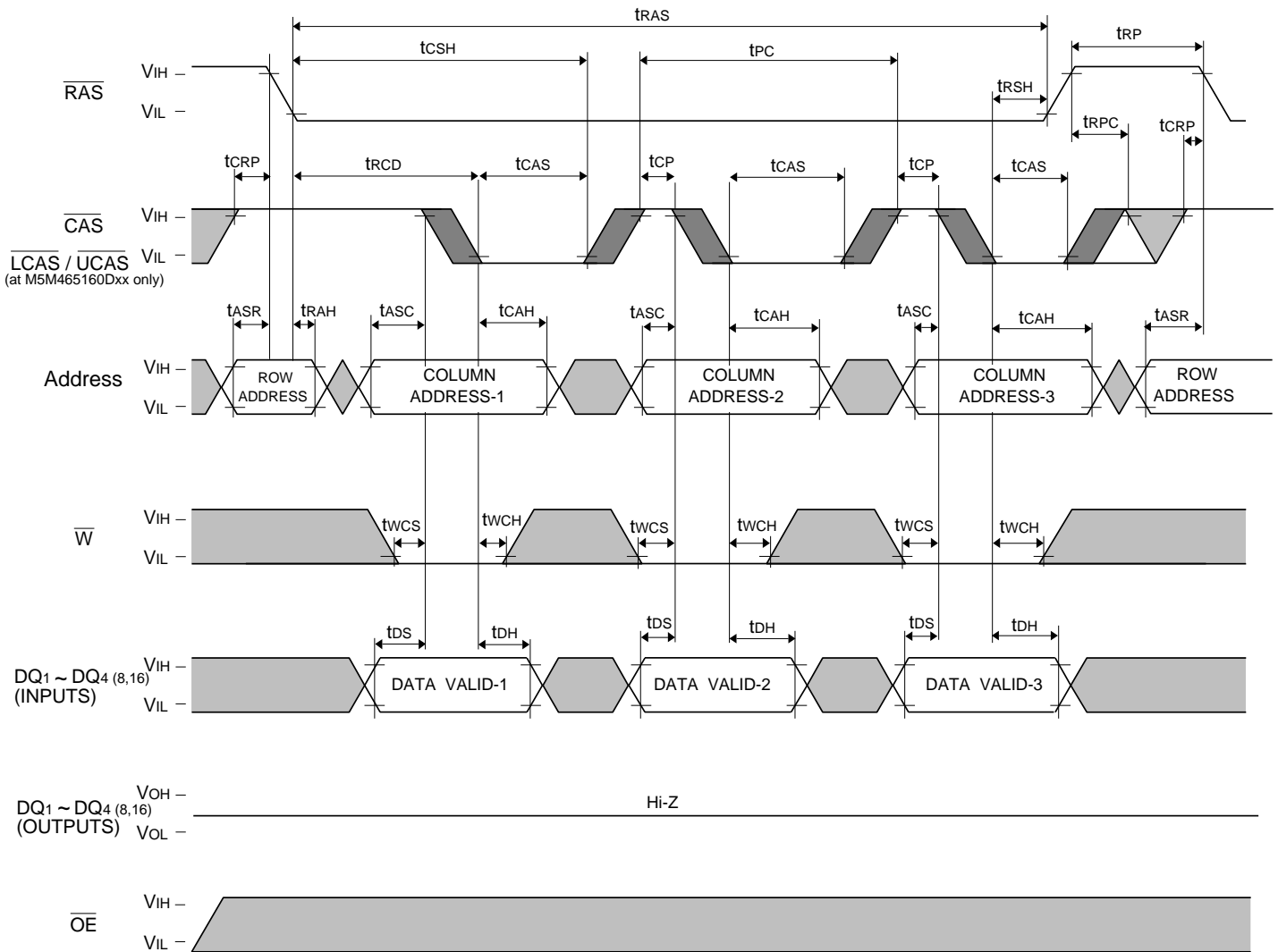

M5M467400/465400DJ,DTP -5,-6,-5S,-6S M5M467800/465800DJ,DTP -5,-6,-5S,-6S M5M465160DJ,DTP -5,-6,-5S,-6S

FAST PAGE MODE 67108864-BIT (1677216-WORD BY 4-BIT) DYNAMIC RAM
FAST PAGE MODE 67108864-BIT (8388608-WORD BY 8-BIT) DYNAMIC RAM
FAST PAGE MODE 67108864-BIT (4194304-WORD BY 16-BIT) DYNAMIC RAM

Fast Page Mode Write Cycle (Delayed Write)

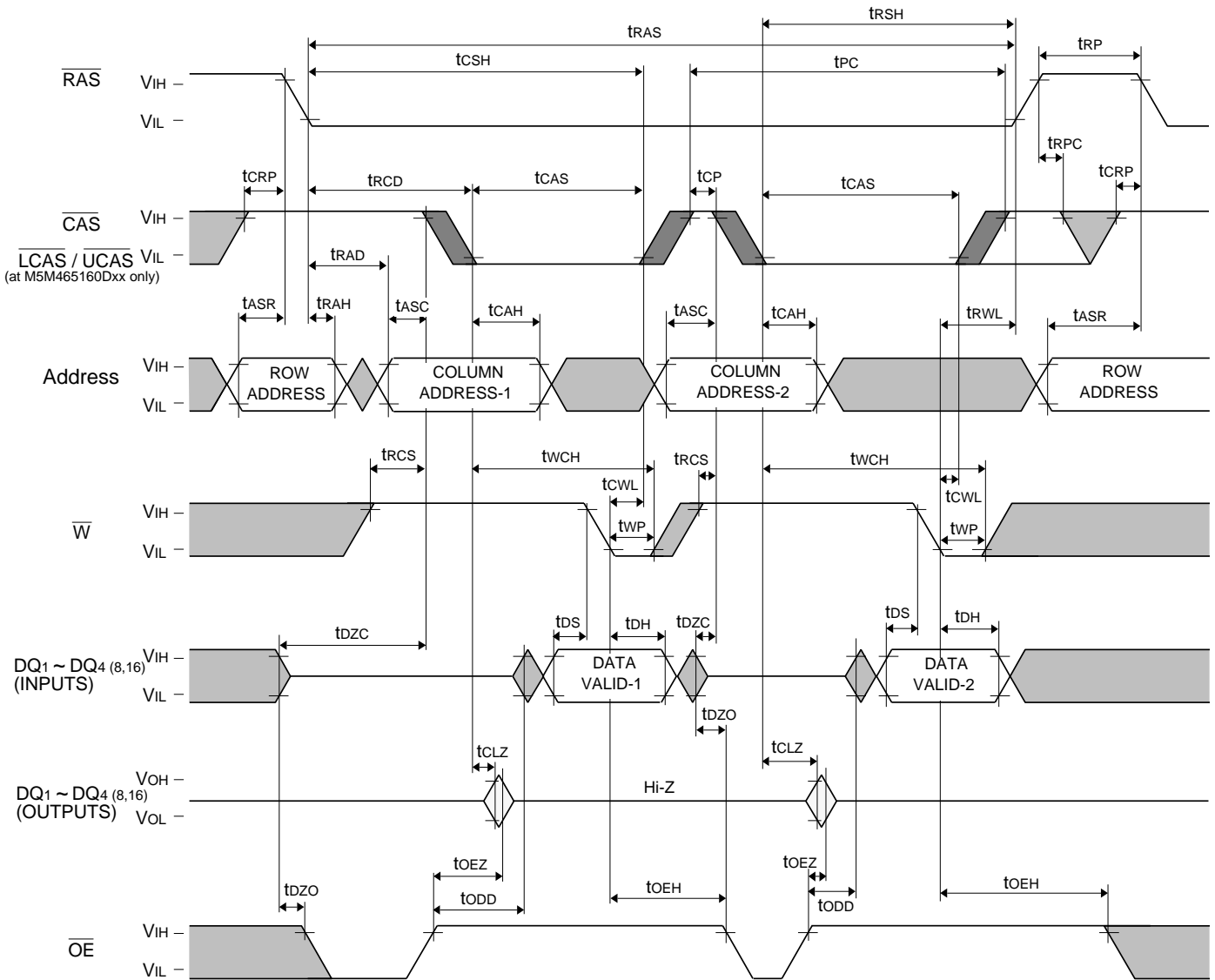

M5M467400/465400DJ,DTP -5,-6,-5S,-6S M5M467800/465800DJ,DTP -5,-6,-5S,-6S M5M465160DJ,DTP -5,-6,-5S,-6S

FAST PAGE MODE 67108864-BIT (1677216-WORD BY 4-BIT) DYNAMIC RAM
FAST PAGE MODE 67108864-BIT (8388608-WORD BY 8-BIT) DYNAMIC RAM
FAST PAGE MODE 67108864-BIT (4194304-WORD BY 16-BIT) DYNAMIC RAM

Fast Page Mode Read-Write, Read-Modify-Write Cycle

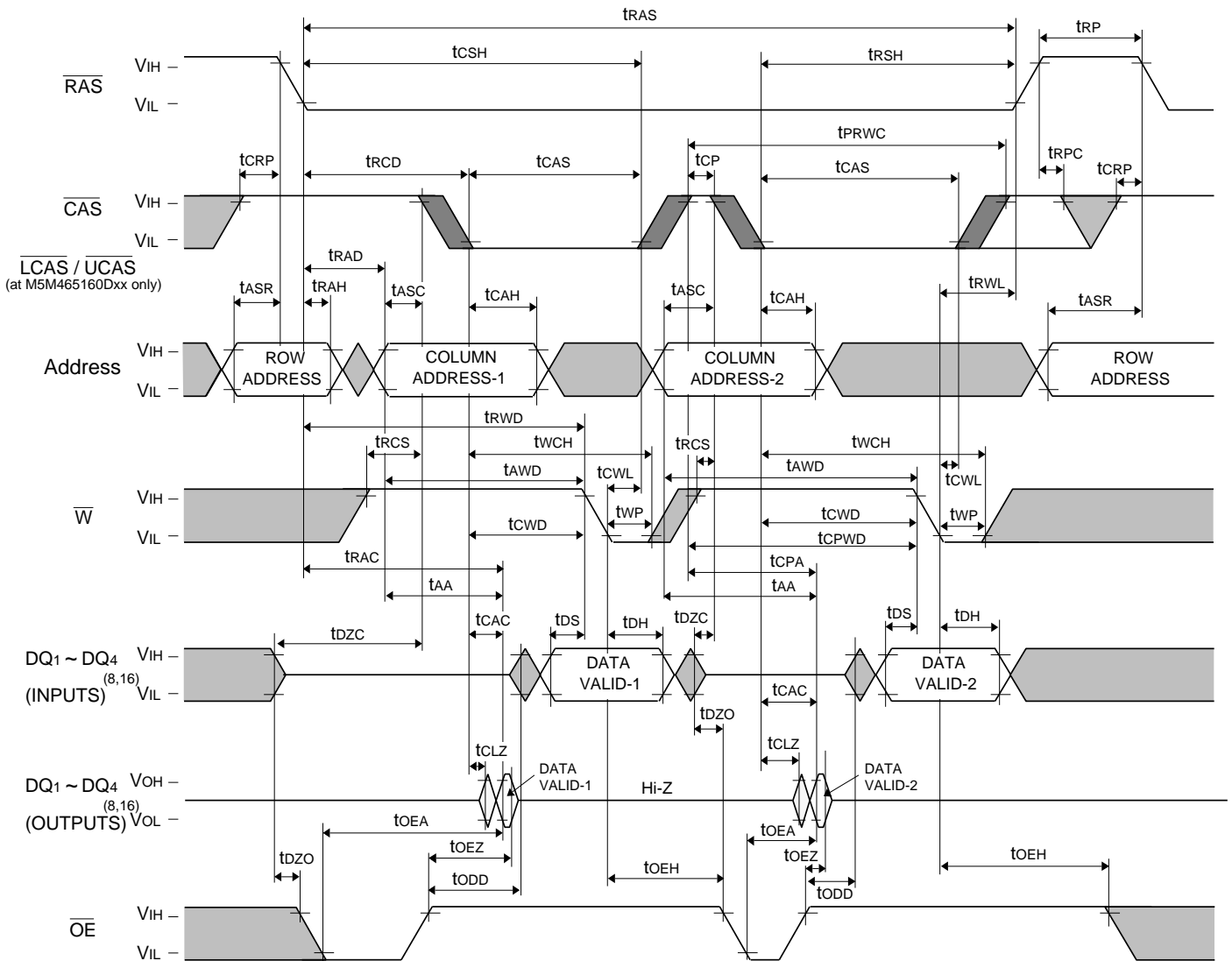

M5M467400/465400DJ,DTP -5,-6,-5S,-6S M5M467800/465800DJ,DTP -5,-6,-5S,-6S M5M465160DJ,DTP -5,-6,-5S,-6S

FAST PAGE MODE 67108864-BIT (16777216-WORD BY 4-BIT) DYNAMIC RAM
FAST PAGE MODE 67108864-BIT (8388608-WORD BY 8-BIT) DYNAMIC RAM
FAST PAGE MODE 67108864-BIT (4194304-WORD BY 16-BIT) DYNAMIC RAM

RAS-only Refresh Cycle

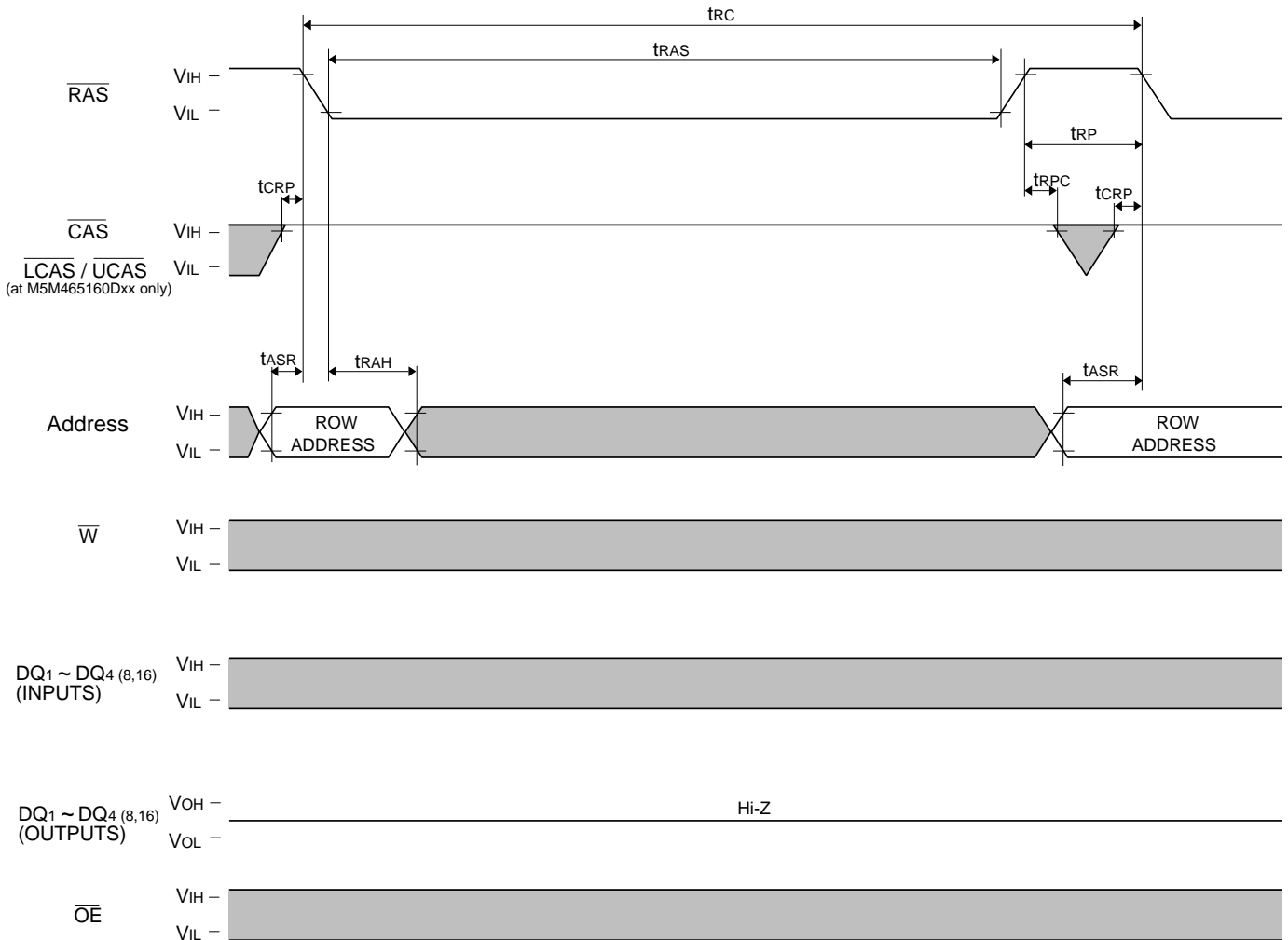

M5M467400/465400DJ,DTP -5,-6,-5S,-6S M5M467800/465800DJ,DTP -5,-6,-5S,-6S M5M465160DJ,DTP -5,-6,-5S,-6S

FAST PAGE MODE 67108864-BIT (16777216-WORD BY 4-BIT) DYNAMIC RAM
FAST PAGE MODE 67108864-BIT (8388608-WORD BY 8-BIT) DYNAMIC RAM
FAST PAGE MODE 67108864-BIT (4194304-WORD BY 16-BIT) DYNAMIC RAM

CAS before RAS Refresh Cycle

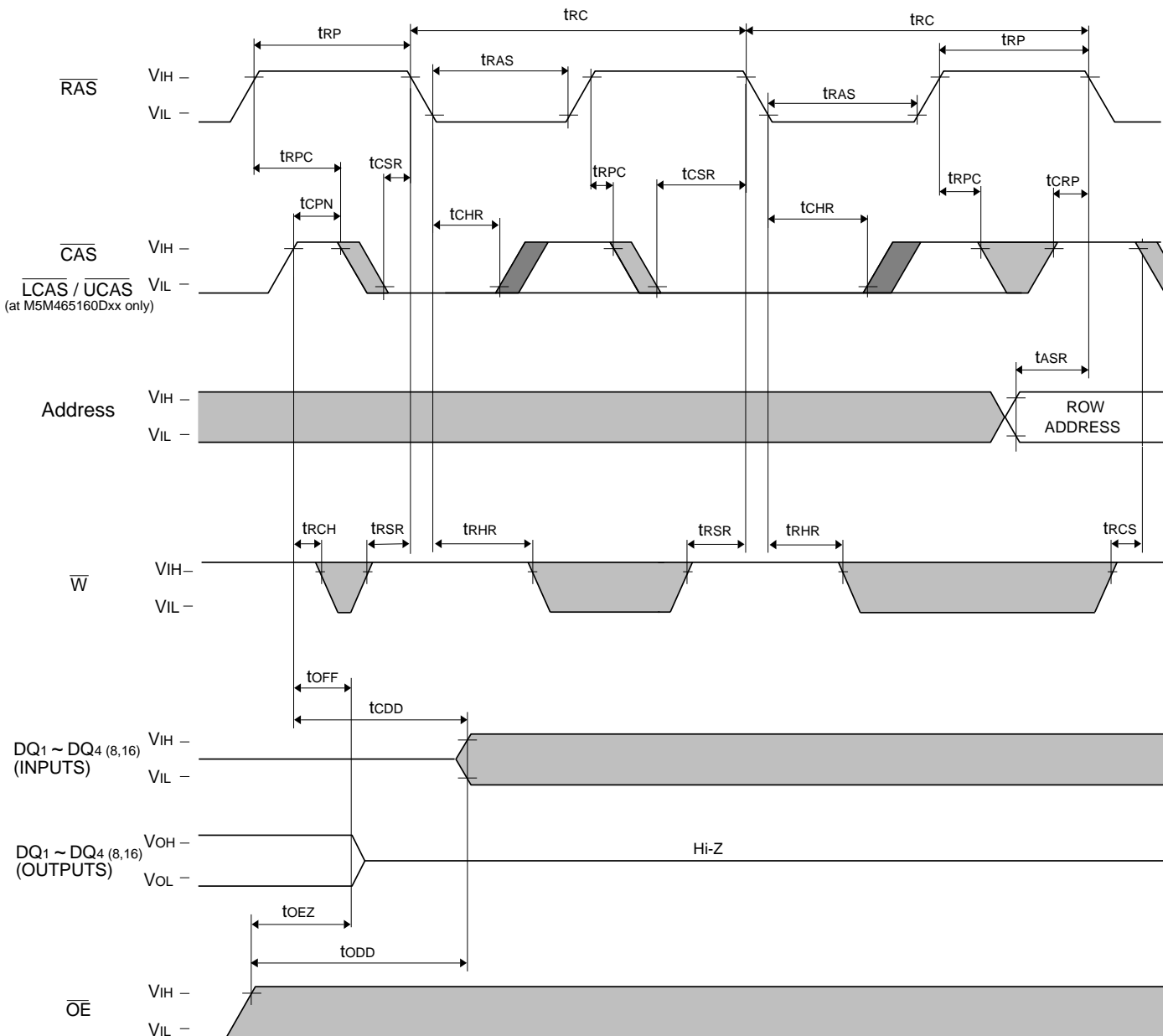

M5M467400/465400DJ,DTP -5,-6,-5S,-6S M5M467800/465800DJ,DTP -5,-6,-5S,-6S M5M465160DJ,DTP -5,-6,-5S,-6S

FAST PAGE MODE 67108864-BIT (16777216-WORD BY 4-BIT) DYNAMIC RAM
FAST PAGE MODE 67108864-BIT (8388608-WORD BY 8-BIT) DYNAMIC RAM
FAST PAGE MODE 67108864-BIT (4194304-WORD BY 16-BIT) DYNAMIC RAM

Hidden Refresh Cycle (Read) (Note 29)

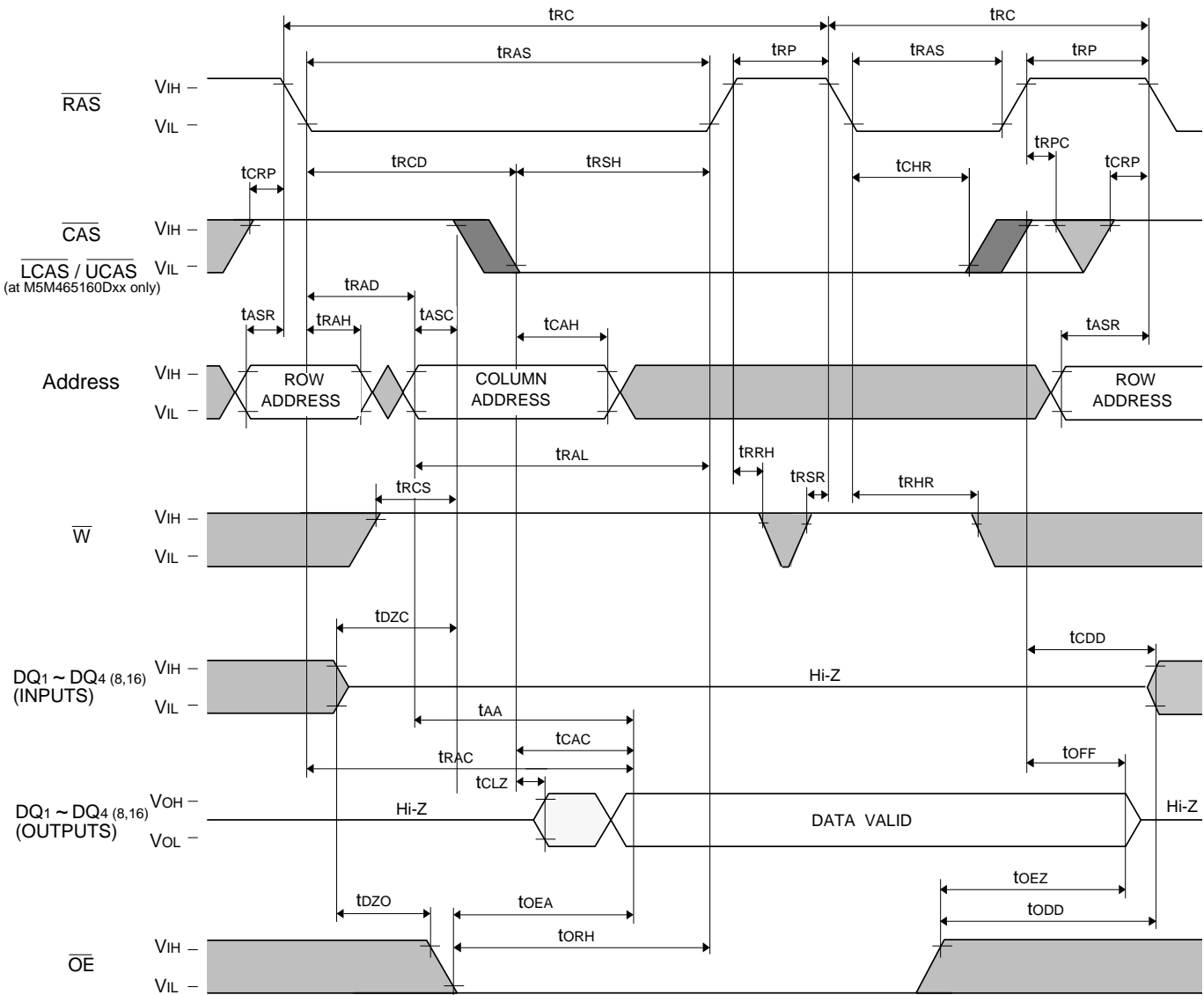

Note 29: Early write, delayed write, read write, or read modify write cycle is applicable instead of read cycle.
Timing requirements and output state are the same as that of each cycle shown above.



M5M467400/465400DJ,DTP -5,-6,-5S,-6S M5M467800/465800DJ,DTP -5,-6,-5S,-6S M5M465160DJ,DTP -5,-6,-5S,-6S

FAST PAGE MODE 67108864-BIT (1677216-WORD BY 4-BIT) DYNAMIC RAM
FAST PAGE MODE 67108864-BIT (8388608-WORD BY 8-BIT) DYNAMIC RAM
FAST PAGE MODE 67108864-BIT (4194304-WORD BY 16-BIT) DYNAMIC RAM

Upper / (Lower) Byte Read Cycle (at M5M465160Dxx only)

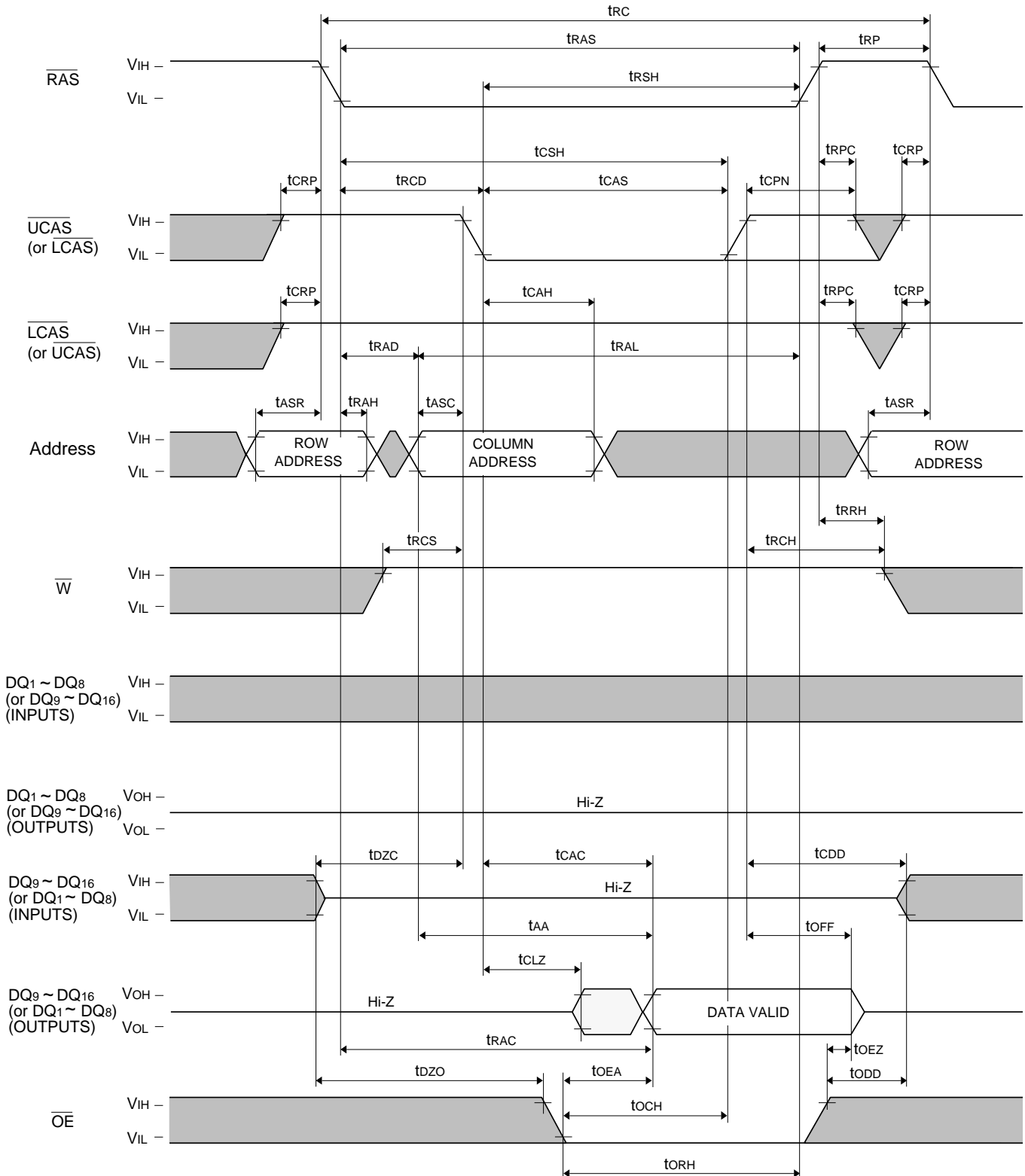

M5M467400/465400DJ,DTP -5,-6,-5S,-6S M5M467800/465800DJ,DTP -5,-6,-5S,-6S M5M465160DJ,DTP -5,-6,-5S,-6S

FAST PAGE MODE 67108864-BIT (16777216-WORD BY 4-BIT) DYNAMIC RAM
FAST PAGE MODE 67108864-BIT (8388608-WORD BY 8-BIT) DYNAMIC RAM
FAST PAGE MODE 67108864-BIT (4194304-WORD BY 16-BIT) DYNAMIC RAM

Upper / (Lower) Byte Write Cycle (Early Write) (at M5M465160Dxx only)

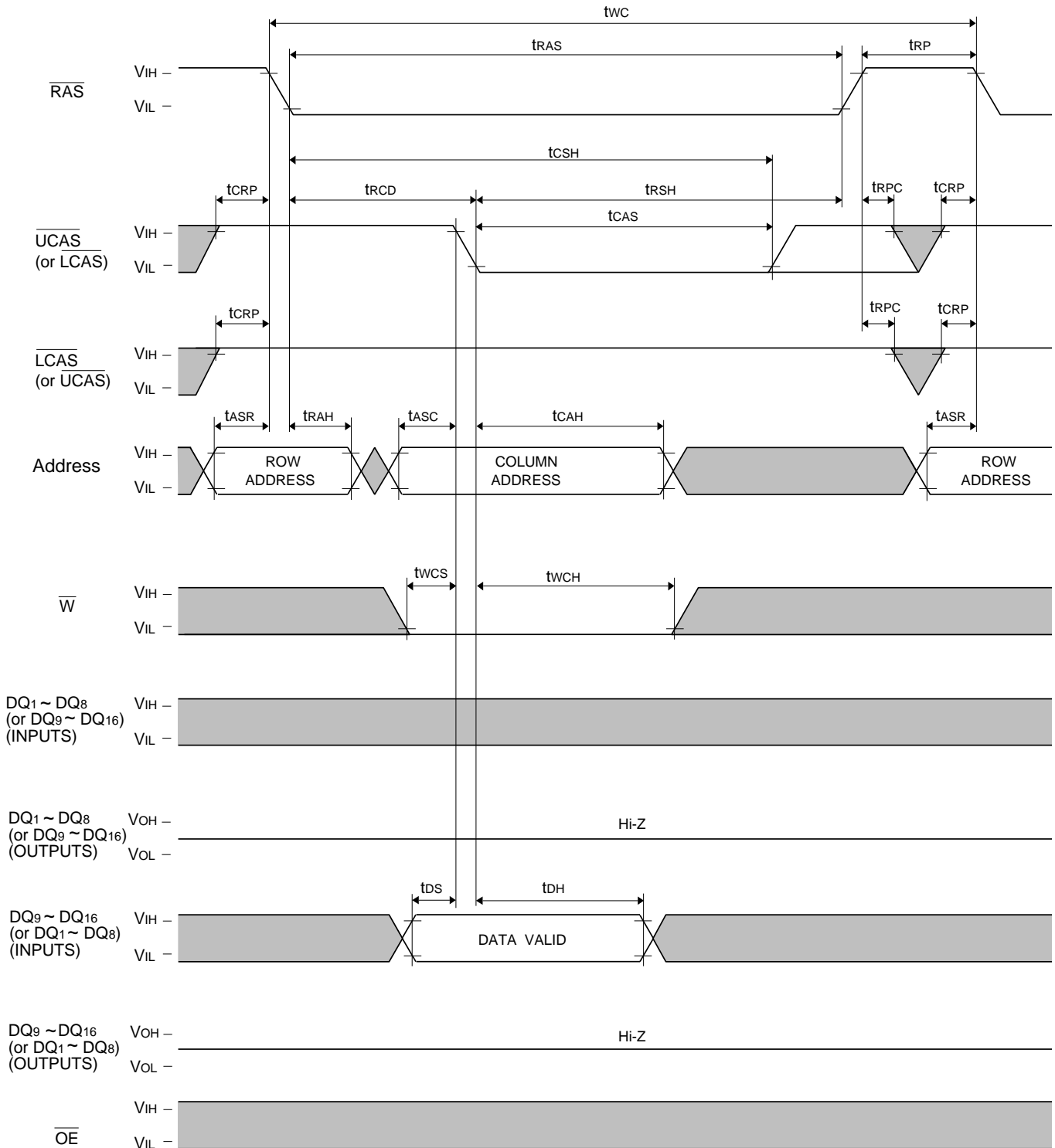

M5M467400/465400DJ,DTP -5,-6,-5S,-6S M5M467800/465800DJ,DTP -5,-6,-5S,-6S M5M465160DJ,DTP -5,-6,-5S,-6S

FAST PAGE MODE 67108864-BIT (1677216-WORD BY 4-BIT) DYNAMIC RAM
FAST PAGE MODE 67108864-BIT (8388608-WORD BY 8-BIT) DYNAMIC RAM
FAST PAGE MODE 67108864-BIT (4194304-WORD BY 16-BIT) DYNAMIC RAM

Upper/(Lower) Byte Read-Write, Upper/(Lower) Byte Read-Modify-Write Cycle (at M5M465160Dxx only)

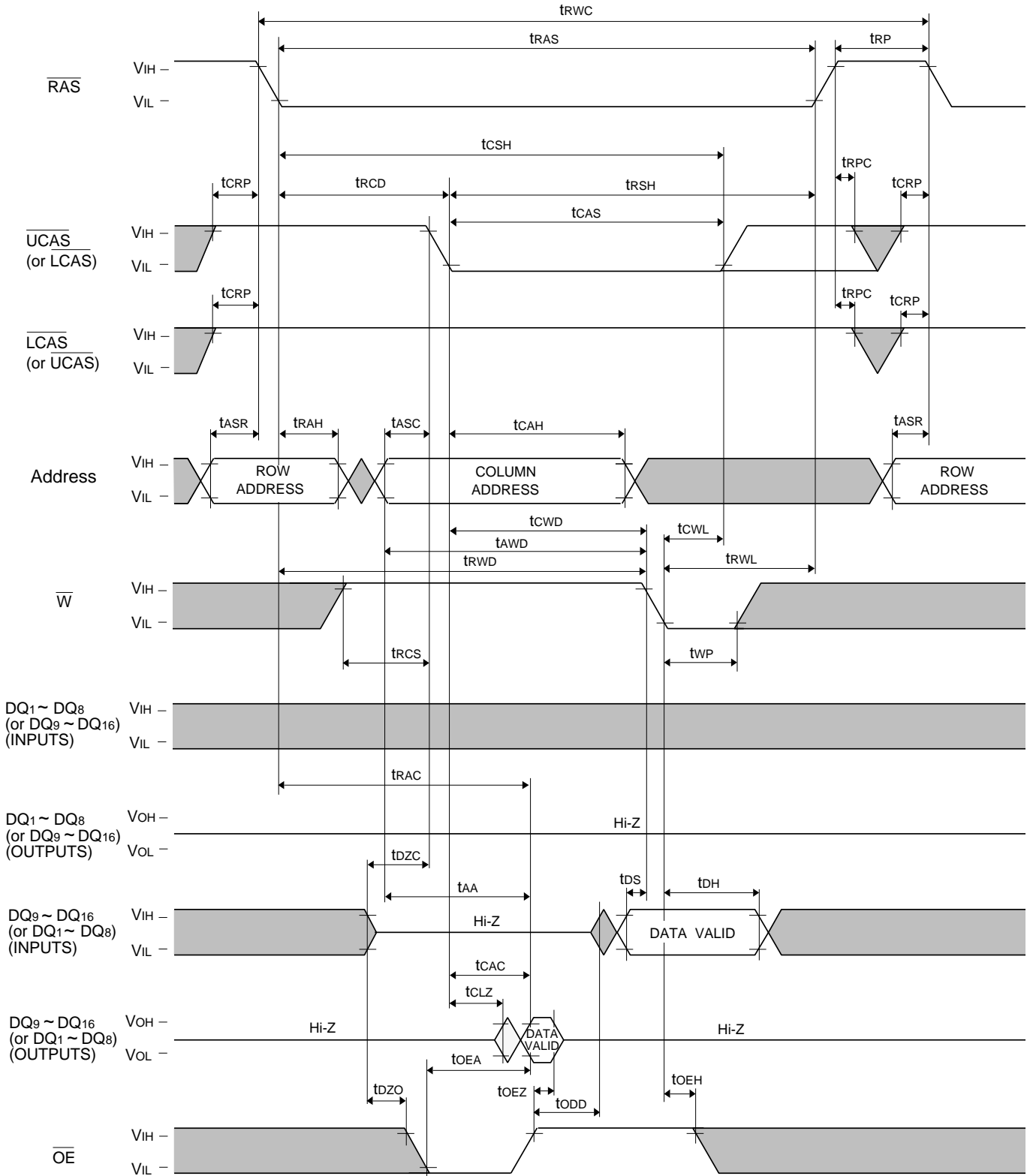

M5M467400/465400DJ,DTP -5,-6,-5S,-6S M5M467800/465800DJ,DTP -5,-6,-5S,-6S M5M465160DJ,DTP -5,-6,-5S,-6S

FAST PAGE MODE 67108864-BIT (1677216-WORD BY 4-BIT) DYNAMIC RAM
FAST PAGE MODE 67108864-BIT (8388608-WORD BY 8-BIT) DYNAMIC RAM
FAST PAGE MODE 67108864-BIT (4194304-WORD BY 16-BIT) DYNAMIC RAM

Fast Page Mode Upper / (Lower) Byte Write Cycle (Early Write) (at M5M465160Dxx only)

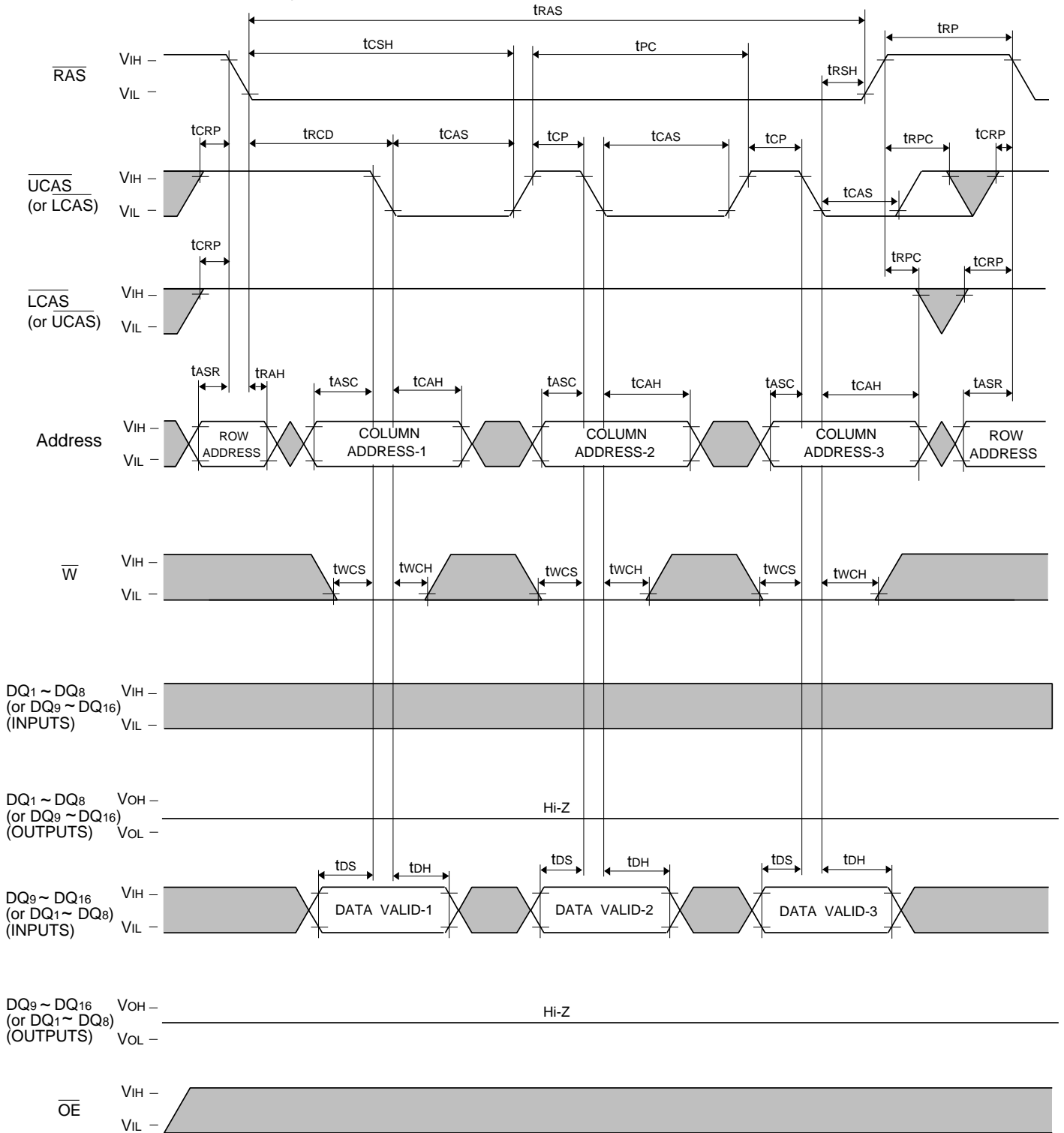

M5M467400/465400DJ,DTP -5,-6,-5S,-6S M5M467800/465800DJ,DTP -5,-6,-5S,-6S M5M465160DJ,DTP -5,-6,-5S,-6S

FAST PAGE MODE 67108864-BIT (1677216-WORD BY 4-BIT) DYNAMIC RAM
FAST PAGE MODE 67108864-BIT (8388608-WORD BY 8-BIT) DYNAMIC RAM
FAST PAGE MODE 67108864-BIT (4194304-WORD BY 16-BIT) DYNAMIC RAM

Fast Page Mode Upper / (Lower) Byte Write Cycle (Delayed Write) (at M5M465160Dxx only)

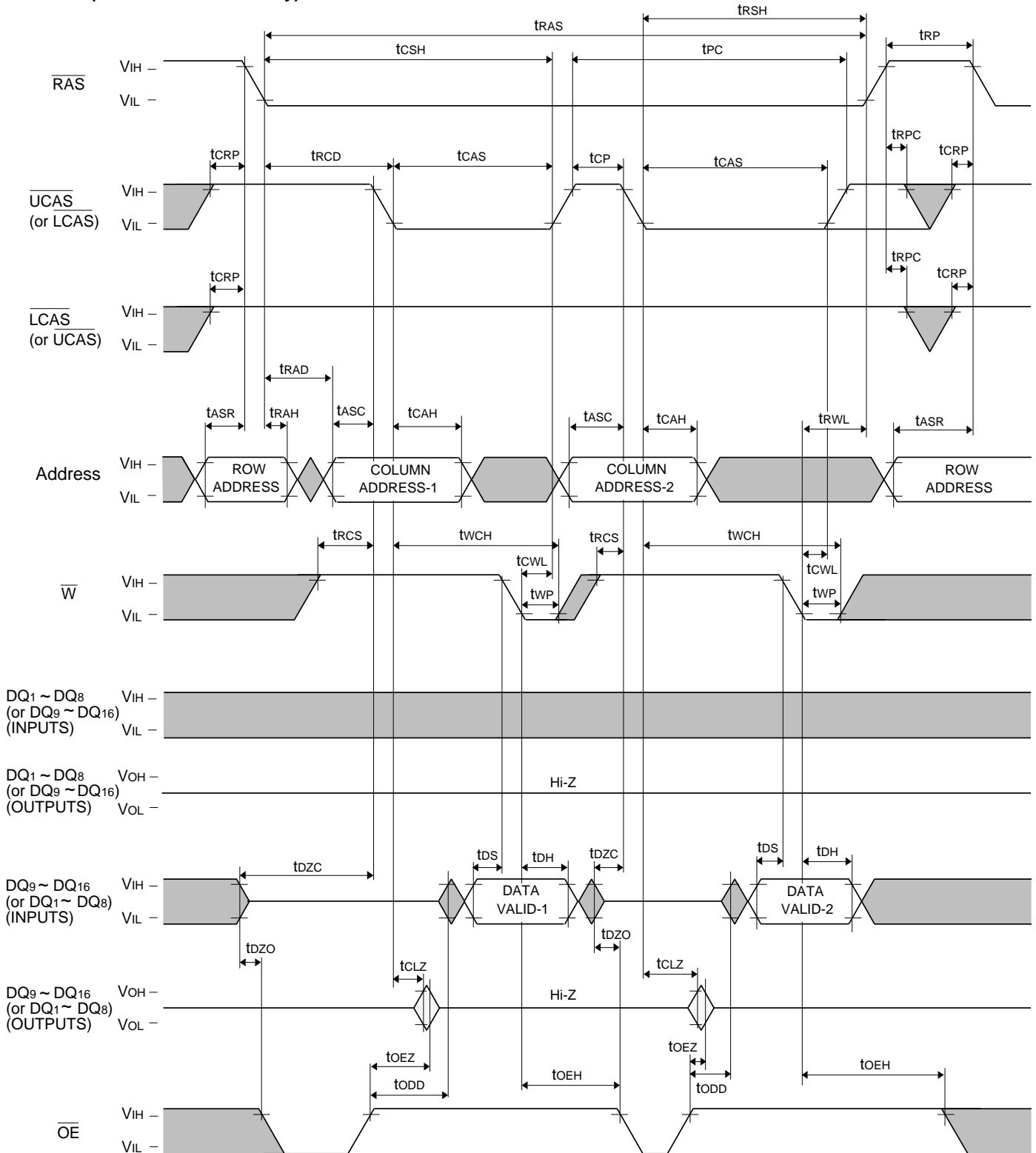

M5M467400/465400DJ,DTP -5,-6,-5S,-6S M5M467800/465800DJ,DTP -5,-6,-5S,-6S M5M465160DJ,DTP -5,-6,-5S,-6S

FAST PAGE MODE 67108864-BIT (16777216-WORD BY 4-BIT) DYNAMIC RAM
FAST PAGE MODE 67108864-BIT (8388608-WORD BY 8-BIT) DYNAMIC RAM
FAST PAGE MODE 67108864-BIT (4194304-WORD BY 16-BIT) DYNAMIC RAM

Upper / (Lower) CAS before RAS Refresh Cycle (at M5M465160Dxx only)

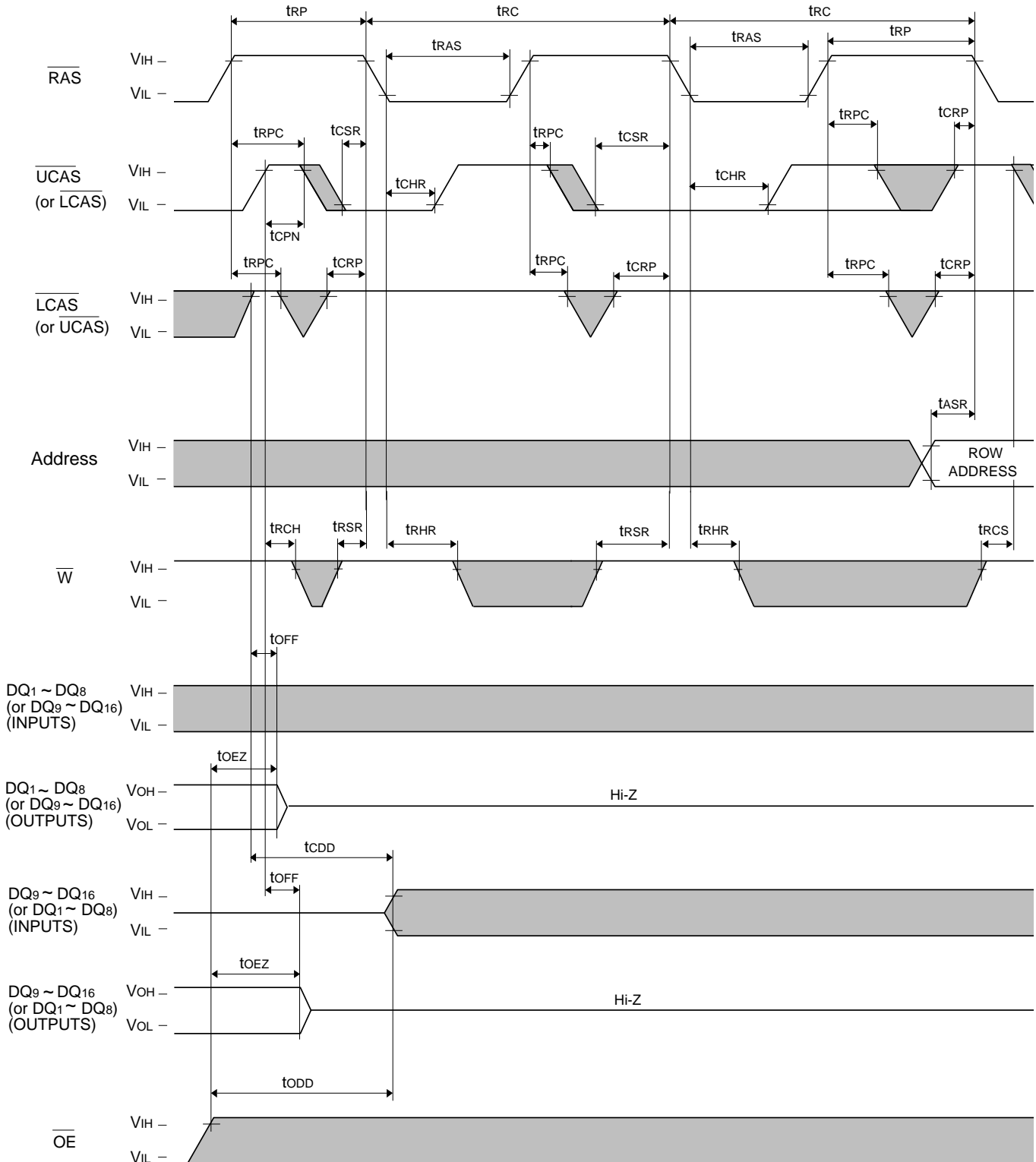

M5M467400/465400DJ,DTP -5,-6,-5S,-6S M5M467800/465800DJ,DTP -5,-6,-5S,-6S M5M465160DJ,DTP -5,-6,-5S,-6S

FAST PAGE MODE 67108864-BIT (16777216-WORD BY 4-BIT) DYNAMIC RAM
FAST PAGE MODE 67108864-BIT (8388608-WORD BY 8-BIT) DYNAMIC RAM
FAST PAGE MODE 67108864-BIT (4194304-WORD BY 16-BIT) DYNAMIC RAM

Upper / (Lower) Hidden Refresh Cycle (Byte Read) (Note 29) (at M5M465160Dxx only)

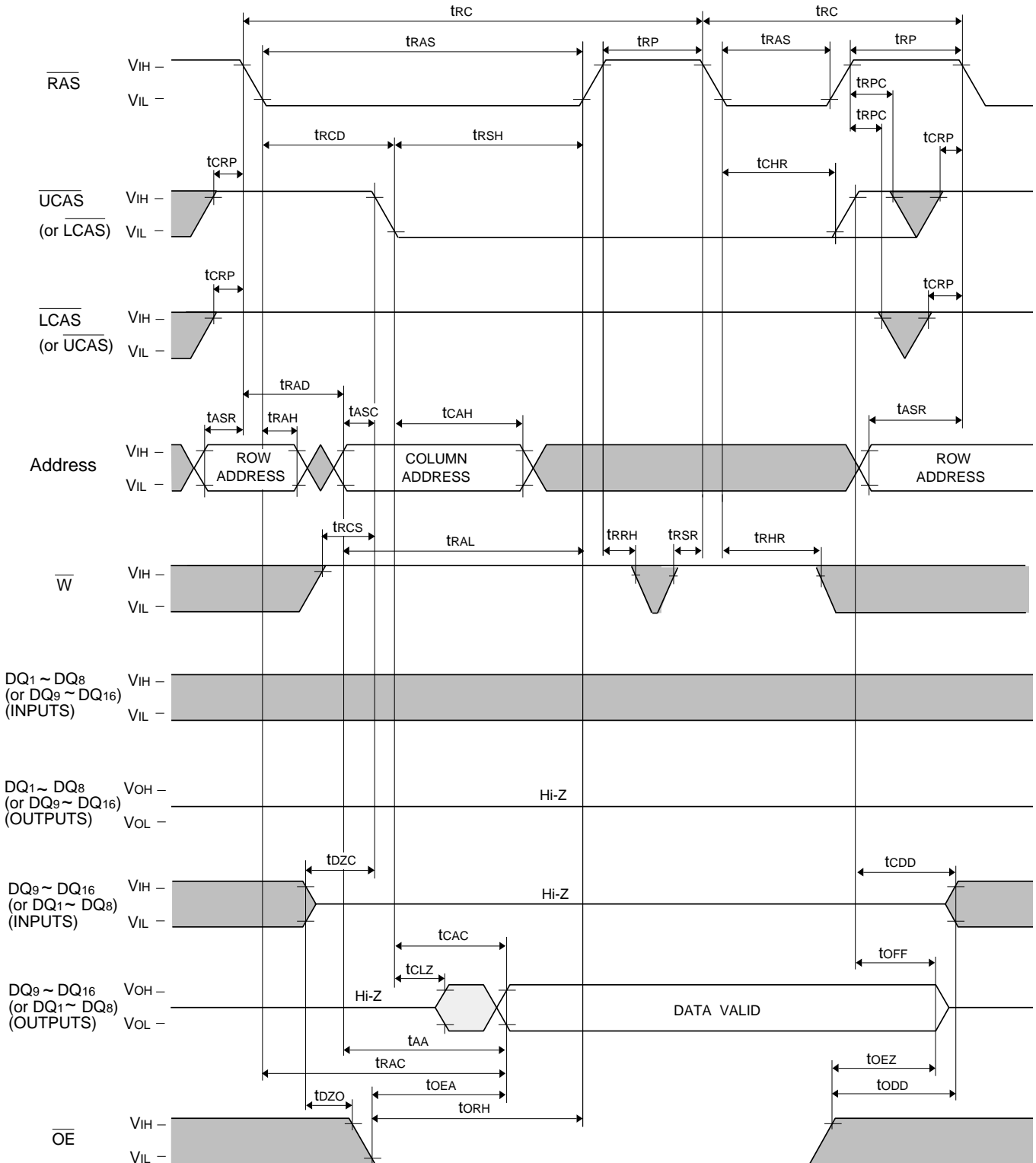

M5M467400/465400DJ,DTP -5,-6,-5S,-6S M5M467800/465800DJ,DTP -5,-6,-5S,-6S M5M465160DJ,DTP -5,-6,-5S,-6S

FAST PAGE MODE 67108864-BIT (16777216-WORD BY 4-BIT) DYNAMIC RAM
FAST PAGE MODE 67108864-BIT (8388608-WORD BY 8-BIT) DYNAMIC RAM
FAST PAGE MODE 67108864-BIT (4194304-WORD BY 16-BIT) DYNAMIC RAM

Byte Self Refresh Cycle (at M5M465160Dxx only)

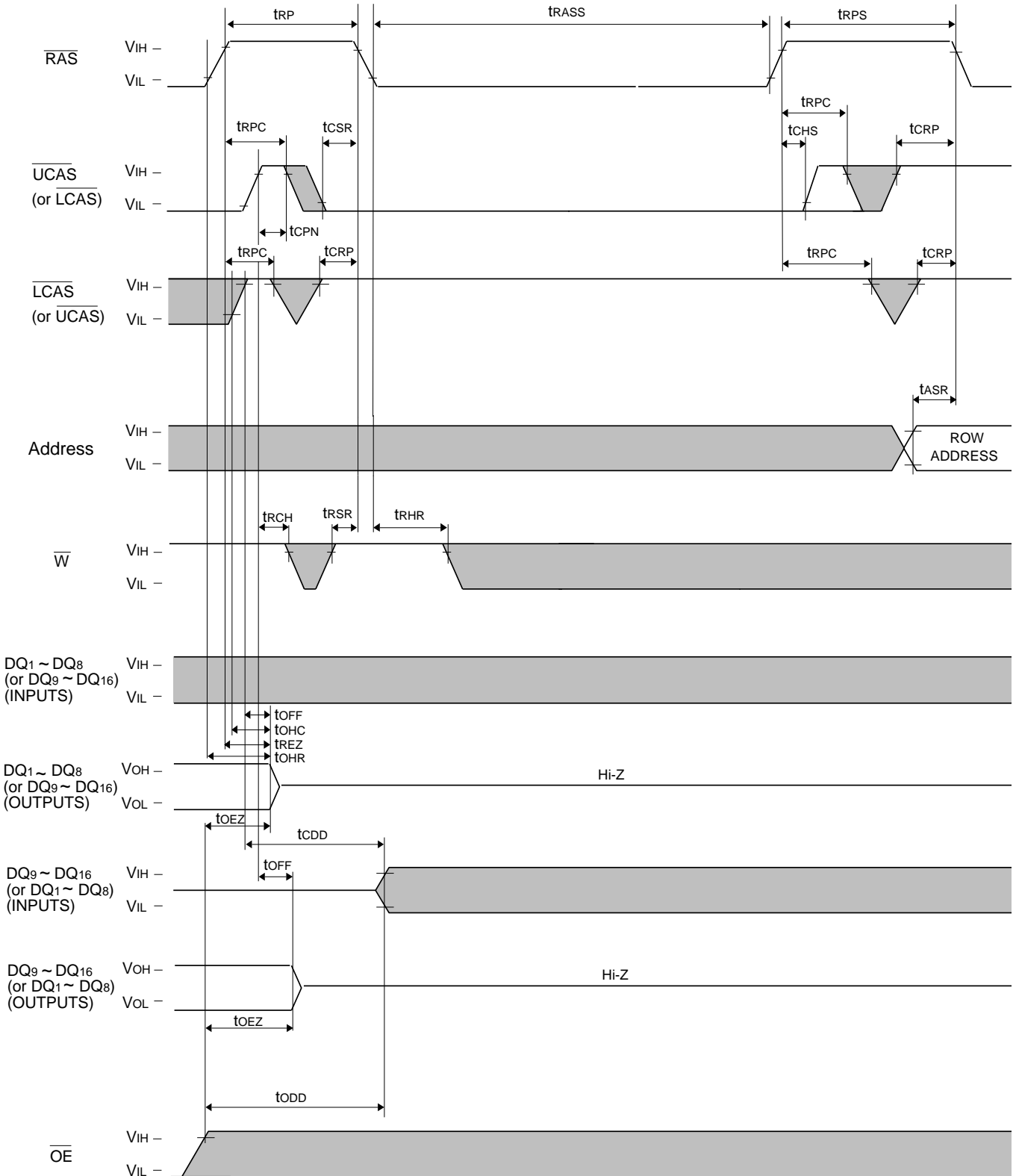

M5M467400/465400DJ,DTP -5,-6,-5S,-6S
M5M467800/465800DJ,DTP -5,-6,-5S,-6S
M5M465160DJ,DTP -5,-6,-5S,-6S

FAST PAGE MODE 67108864-BIT (16777216-WORD BY 4-BIT) DYNAMIC RAM
FAST PAGE MODE 67108864-BIT (8388608-WORD BY 8-BIT) DYNAMIC RAM
FAST PAGE MODE 67108864-BIT (4194304-WORD BY 16-BIT) DYNAMIC RAM

Keep safety first in your circuit designs!

- Mitsubishi Electric Corporation puts the maximum effort into making semiconductor products better and more reliable, but there is always the possibility that trouble may occur with them. Trouble with semiconductors consideration to safety when making your circuit designs, with appropriate measures such as (i) placement of substitutive, auxiliary circuits, (ii) use of non-flammable material or (iii) prevention against any malfunction or mishap.

Notes regarding these materials

- These materials are intended as a reference to assist our customers in the selection of the Mitsubishi semiconductor product best suited to the customer's application; they do not convey any license under any intellectual property rights, or any other rights, belonging to Mitsubishi Electric Corporation or a third party.
- Mitsubishi Electric Corporation assumes no responsibility for any damage, or infringement of any third-party's rights, originating in the use of any product data, diagrams, charts or circuit application examples contained in these materials.
- All information contained in these materials, including product data, diagrams and charts, represent information on products at the time of publication of these materials, and are subject to change by Mitsubishi Electric Corporation without notice due to product improvements or other reasons. It is therefore recommended that customers contact Mitsubishi Electric Corporation or an authorized Mitsubishi Semiconductor product distributor for the latest product information before purchasing a product listed herein.
- Mitsubishi Electric Corporation semiconductors are not designed or manufactured for use in a device or system that is used under circumstances in which human life is potentially at stake. Please contact Mitsubishi Electric Corporation or an authorized Mitsubishi Semiconductor product distributor when considering the use of a product contained herein for special applications, such as apparatus or systems for transportation, vehicular, medical, aerospace, nuclear, or undersea repeater use.
- The prior written approval of Mitsubishi Electric Corporation is necessary to reprint or reproduce in whole or in part these materials.
- If these products or technologies are subject to the Japanese export control restrictions, they must be exported under a license from the Japanese government and cannot be imported into a country other than the approved destination.
Any diversion or reexport contrary to the export control laws and regulations of Japan and/or the country of destination is prohibited.
- Please contact Mitsubishi Electric Corporation or an authorized Mitsubishi Semiconductor product distributor for further details on these materials or the products contained therein.