

# M62261FP

## VOLTAGE CONVERTER FOR MMIC

### DESCRIPTION

The M62261FP is a C-MOS semiconductor circuit for driving MMIC, by connecting to the external capacitance, it can generate 2-times of inverting input voltage.

With resident charge-pump type 2-times inverting input voltage circuit,  $-V_{out}$  and  $-2V_{out}$  can perform 2 kinds of negative source system.

### FEATURES

- By connecting to external capacitance, it can generate 2-times of inverting input voltage.
- Capability of output current ..... 10mA(Min.)
- Low voltage operation is possible .....  $V_{IN}=3V(Typ.)$
- Small size 8 pin package.

### APPLICATION

MMIC for cordless telephone

### PIN CONFIGURATION (TOP VIEW)

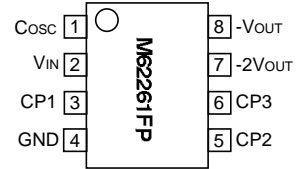

Outline 8P2S-A

### BLOCK DIAGRAM

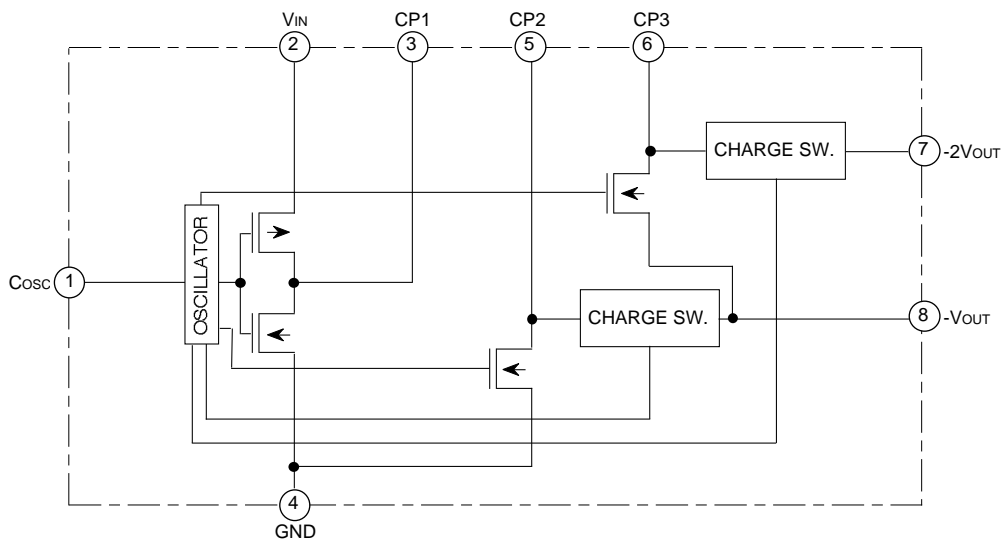

**EXPLANATION OF TERMINALS**

Pin No.	Symbol	Function
①	Cosc	Connect pin for capacitance of oscillator circuit
②	V <sub>IN</sub>	Input voltage
③	CP1	Connect pin 1 for capacitance of charge-pump
④	GND	GND pin
⑤	CP2	Connect pin 2 for capacitance of charge-pump
⑥	CP3	Connect pin 3 for capacitance of charge-pump
⑦	-2V <sub>OUT</sub>	Output pin of 2-times inverting input voltage
⑧	-V <sub>OUT</sub>	Output pin of inverting input voltage

**ABSOLUTE MAXIMUM RATINGS** (Ta=25°C, unless otherwise noted)

Symbol	Parameter	Conditions	Ratings	Unit
V <sub>IN</sub>	Supply voltage		6	V
P <sub>d</sub>	Power dissipation	Ta=25°C	440	mW
T <sub>opr</sub>	Operating temperature		-20 to +75	°C
T <sub>stg</sub>	Storage temperature		-40 to +125	°C

**ELECTRICAL CHARACTERISTICS** (V<sub>IN</sub>=3V, Ta=25°C, C<sub>osc</sub>=220pF, unless otherwise noted)

Symbol	Parameter	Test conditions	Limits			Unit
			Min.	Typ.	Max.	
I <sub>CC</sub>	Dissipation current			350	900	μA
V <sub>IN</sub>	Range of source voltage		2.7		5.5	V
R <sub>O1</sub>	Output resistor	-V <sub>OUT</sub> output pin (with load at -V <sub>OUT</sub> pin only)		40	80	
R <sub>O2</sub>		-2V <sub>OUT</sub> output pin (with load at -2V <sub>OUT</sub> pin only)		120	240	
V <sub>EF</sub>	Efficiency of voltage convert	RL=	95	99.8		%
PEF1	Efficiency of power convert	-V <sub>OUT</sub> output, I <sub>L1</sub> =5mA		90		%
PEF2		-2V <sub>OUT</sub> output, I <sub>L2</sub> =5mA		90		%
f <sub>OSC</sub>	Oscillating frequency	C <sub>osc</sub> =220pF	2	6	10	kHz

**APPLICATION EXAMPLE**

