

DS75124 Triple Line Receiver

General Description

The DS75124 is designed to meet the input/output interface specifications for IBM System 360. It has built-in hysteresis on one input on each of the three receivers to provide large noise margin. The other inputs on each receiver are in a standard TTL configuration. The DS75124 is compatible with standard TTL logic and supply voltage levels.

Features

- Built-in input threshold hysteresis
- High speed . . . typical propagation delay time 20 ns
- Independent channel strobes
- Input gating increases application flexibility
- Single 5.0V supply operation
- Plug-in replacement for the SN75124 and the 8T24

Connection Diagram and Truth Table

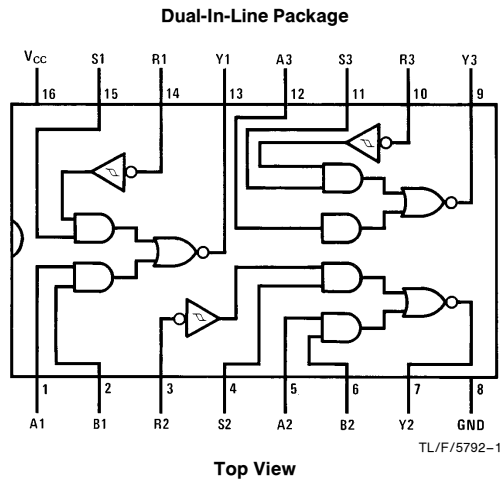

Inputs				Output
A	B†	R	S	Y
H	H	X	X	L
X	X	L	H	L
L	X	H	X	H
L	X	X	L	H
X	L	H	X	H
X	L	X	L	H

H = high level, L = low level, X = irrelevant
 †B input and last two lines of the truth table are applicable to receivers 1 and 2 only

Order Number DS75124N
 See NS Package Number N16A

Typical Application

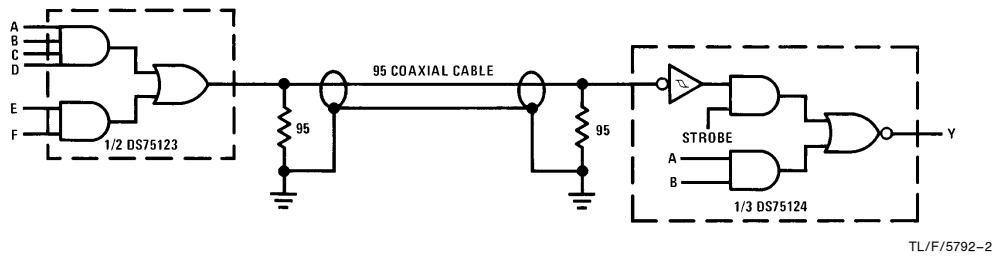

Absolute Maximum Ratings (Note 1)

If Military/Aerospace specified devices are required, please contact the National Semiconductor Sales Office/Distributors for availability and specifications.

Supply Voltage, V_{CC}	7.0V
Input Voltage	
R Input with V_{CC} Applied	7.0V
R Input with V_{CC} not Applied	6.0V
A, B, or S Input	5.5V
Output Voltage	7.0V
Output Current	± 100 mA
Maximum Power Dissipation* at 25°C	
Molded Package	1362 mW

Operating Temperature Range	0°C to +75°C
Storage Temperature Range	-65°C to +150°C
Lead Temperature (Soldering, 4 seconds)	260°C
*Derate molded package 10.9 mW/°C above 25°C.	

Operating Conditions

	Min	Max	Units
Supply Voltage, V_{CC}	4.75	5.25	V
High Level Output Current, I_{OH}		-800	μ A
Low Level Output Current, I_{OL}		16	mA
Operating Temperature, T_A	0	+75	°C

Electrical Characteristics (Notes 2 and 3)

Symbol	Parameter	Conditions	Min	Typ	Max	Units	
V_{IH}	High Level Input Voltage	A, B, or S	2.0			V	
		R	1.7			V	
V_{IL}	Low Level Input Voltage	A, B, or S			0.8	V	
		R			0.8	V	
$V_{T+} - V_{T-}$	Hysteresis	$V_{CC} = 5.0V, T_A = 25^\circ C, R, (Note\ 6)$	0.2	0.4		V	
V_I	Input Clamp Voltage	$V_{CC} = 5.0V, I_I = -12\ mA, A, B, or\ S$			-1.5	V	
I_I	Input Current at Maximum Input Voltage	$V_{CC} = 5.25V, V_{IN} = 5.5V, A, B, or\ S$			1	mA	
		R	$V_I = 7.0V$			5.0	mA
		$V_I = 6.0V, V_{CC} = 0V$				5.0	mA
V_{OH}	High Level Output Voltage	$V_{IH} = V_{IHMIN}, V_{IL} = V_{ILMAX}, I_{OH} = -800\ \mu A, (Note\ 4)$	2.6			V	
V_{OL}	Low Level Output Voltage	$V_{IH} = V_{IHMIN}, V_{IL} = V_{ILMAX}, I_{OL} = 16\ mA, (Note\ 4)$			0.4	V	
I_{IH}	High Level Input Current	$V_I = 4.5V, A, B, or\ S$			40	μ A	
		$V_I = 3.11V, R$			170	μ A	
I_{IL}	Low Level Input Current	$V_I = 0.4V, A, B, or\ S$	-0.1		-1.6	mA	
I_{OS}	Short Circuit Output Current	$V_{CC} = 5.0V, T_A = 25^\circ C, (Note\ 5)$	-50		-100	mA	
I_{CC}	Supply Current	$V_{CC} = 5.25V$			72	mA	

Switching Characteristics $T_A = 25^\circ C$, nominal power supplies unless otherwise noted

Symbol	Parameter	Conditions	Min	Typ	Max	Units
t_{PLH}	Propagation Delay Time, Low-to-High Level Output from R Input	(See AC Test Circuit and Switching Time Waveforms)		20	30	ns
t_{PHL}	Propagation Delay Time, High-to-Low Level Output from R Input	(See AC Test Circuit and Switching Time Waveforms)		20	30	ns

Note 1: "Absolute Maximum Ratings" are those values beyond which the safety of the device cannot be guaranteed. Except for "Operating Temperature Range" they are not meant to imply that the devices should be operated at these limits. The table of "Electrical Characteristics" provides conditions for actual device operation.

Note 2: All currents into device pins are shown as positive, currents out of device pins shown as negative, all voltage values are referenced with respect to network ground terminal, unless otherwise noted. All values shown as max or min on absolute value basis.

Note 3: Min/max limits apply across the guaranteed operating temperature range of 0°C to +75°C for DS75124, unless otherwise specified. Typicals are for $V_{CC} = 5.0V, T_A = 25^\circ C$. Positive current is defined as current into the referenced pin.

Note 4: The output voltage and current limits are guaranteed for any appropriate combination of high and low inputs specified by the truth table for the desired output.

Note 5: Not more than one output should be shorted at a time.

Note 6: Hysteresis is the difference between the positive going input threshold voltage, V_{T+} , and the negative going input threshold voltage, V_{T-} .

AC Test Circuit and Switching Time Waveforms

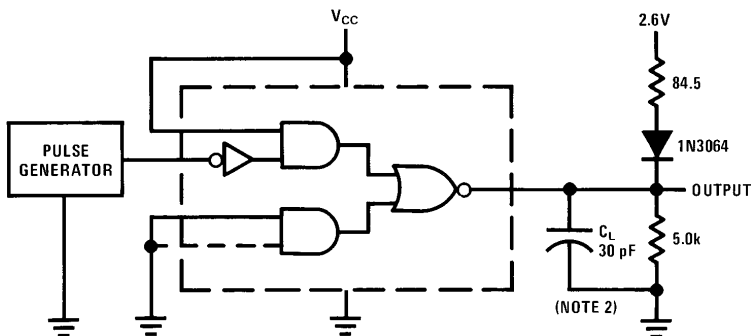

TL/F/5792-3

Note 1: The pulse generator has the following characteristics: $Z_{OUT} \approx 50\Omega$, $t_W = 200$ ns, duty cycle = 50%

Note 2: C_L includes probe and jig capacitance.

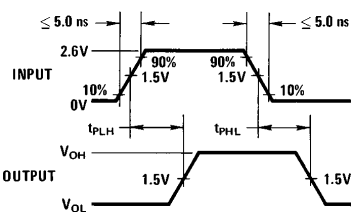

TL/F/5792-4

Typical Performance Characteristics

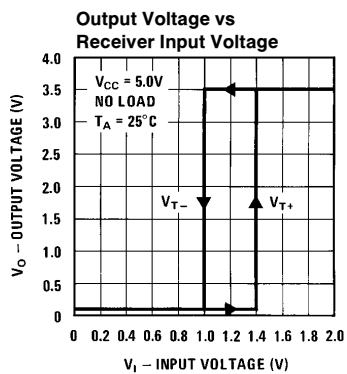

TL/F/5792-5

Physical Dimensions inches (millimeters)

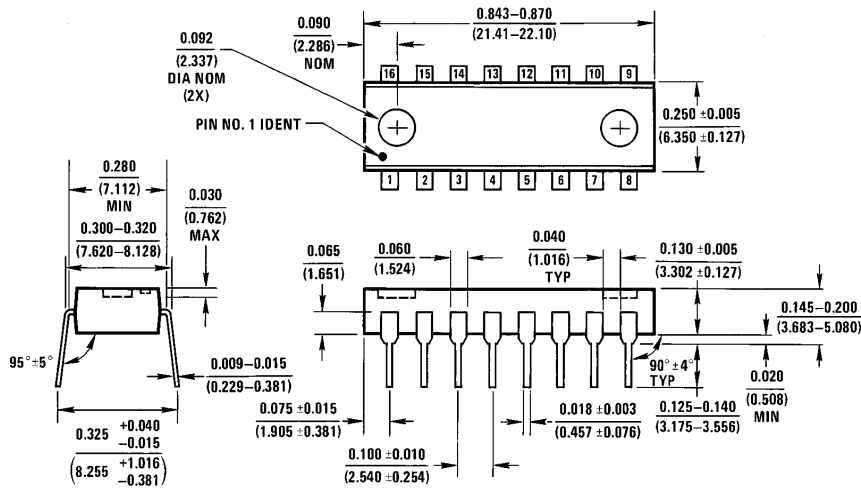

Molded Dual-In-Line Package (N)
Order Number DS75124N
NS Package Number N16A

N16A (REV E)

LIFE SUPPORT POLICY

NATIONAL'S PRODUCTS ARE NOT AUTHORIZED FOR USE AS CRITICAL COMPONENTS IN LIFE SUPPORT DEVICES OR SYSTEMS WITHOUT THE EXPRESS WRITTEN APPROVAL OF THE PRESIDENT OF NATIONAL SEMICONDUCTOR CORPORATION. As used herein:

1. Life support devices or systems are devices or systems which, (a) are intended for surgical implant into the body, or (b) support or sustain life, and whose failure to perform, when properly used in accordance with instructions for use provided in the labeling, can be reasonably expected to result in a significant injury to the user.
2. A critical component is any component of a life support device or system whose failure to perform can be reasonably expected to cause the failure of the life support device or system, or to affect its safety or effectiveness.



National Semiconductor Corporation
 1111 West Bardin Road
 Arlington, TX 76017
 Tel: 1(800) 272-9959
 Fax: 1(800) 737-7018

<http://www.national.com>

National Semiconductor Europe

Fax: +49 (0) 180-530 85 86
 Email: europe.support@nsc.com
 Deutsch Tel: +49 (0) 180-530 85 85
 English Tel: +49 (0) 180-532 78 32
 Français Tel: +49 (0) 180-532 93 58
 Italiano Tel: +49 (0) 180-534 16 80

National Semiconductor Hong Kong Ltd.

19th Floor, Straight Block,
 Ocean Centre, 5 Canton Rd.
 Tsimshatsui, Kowloon
 Hong Kong
 Tel: (852) 2737-1600
 Fax: (852) 2736-9960

National Semiconductor Japan Ltd.

Tel: 81-043-299-2308
 Fax: 81-043-299-2408

National does not assume any responsibility for use of any circuitry described, no circuit patent licenses are implied and National reserves the right at any time without notice to change said circuitry and specifications.