

White LED Step-Up Converter in Tiny Package

General Description

The RT9271 is a step-up DC/DC converter specifically designed to drive white LEDs with a constant current. The device can drive one to four LEDs in series from a Li-Ion cell. Series connection of the LEDs provides identical LED currents resulting in uniform brightness and eliminating the need for ballast resistors. The RT9271 switches at 1.1 MHz, allowing the use of tiny external components. The input and output capacitor can be as small as 1uF, saving space and cost versus alternative solutions. A low 0.25V feedback voltage minimizes power loss in the current setting resistor for better efficiency.

The RT9271 is available in low profile SOT-26 package.

Ordering Information

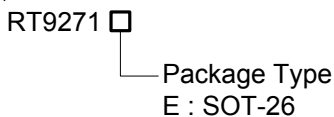

Marking Information

For marking information, contact our sales representative directly or through a RichTek distributor located in your area, otherwise visit our website for detail.

Functional Pin Description

Pin	Name	Function
1	LX	Switch Pin. Connect inductor/diode here. Minimize trace area at this pin to reduce EMI
2	GND	Ground Pin. Connect directly to local ground plane.
3	FB	Feedback Pin. Reference voltage is 0.25V. Connect cathode of lowest LED and resistor here. Calculate resistor value according to the formula: $R_{FB} = 0.25/I_{LED}$
4	CE	Chip Enable Pin. Connect to 1.4V or higher to enable device, 0.4V or less to disable device.
5	OVP	Over Voltage Protection Pin. Voltage sensing input to trigger the function of over voltage protection, the trip point is 15.5V. Leave it unconnected to disable this function.
6	VCC	Input Voltage Pin. Must be locally bypass with 1uF capacitor to GND.

Features

- Inherently Matched LED Current
- High Efficiency: 85% Typical
- Drives Up to Four LEDs from 2.8V Supply
- 20V Internal Switch
- Fast 1.1 MHz Switching Frequency
- Uses Tiny 1 mm Tall Inductors
- Requires Only 1uF Output Capacitor
- Low Profile SOT-26 Package
- Optional 15V Over Voltage Protection

Applications

- Mobile Phone
- Digital Still Camera
- PDAs, Handheld Computers
- MP3 Players
- GPS Receivers

Pin Configurations

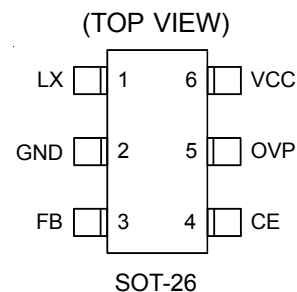

Typical Application Circuit

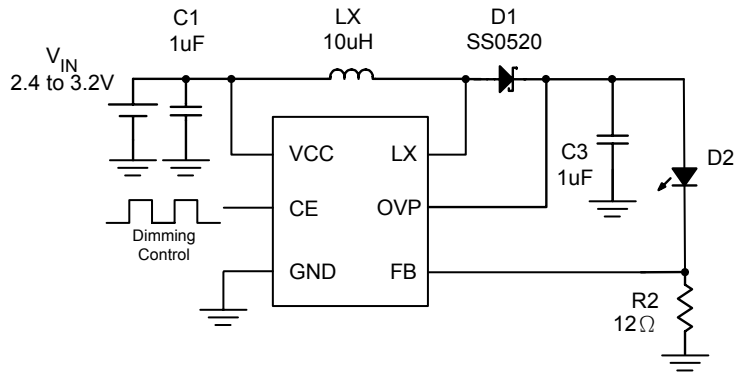

Figure 1. RT9271 Drivers 1 WLED Application Circuit

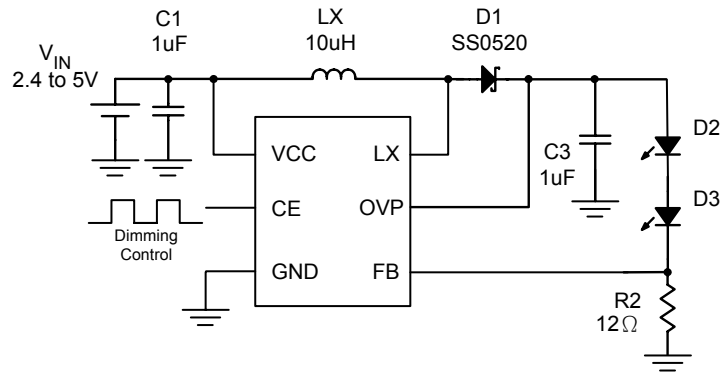

Figure 2. RT9271 Drivers 2 Series WLEDs Application Circuit

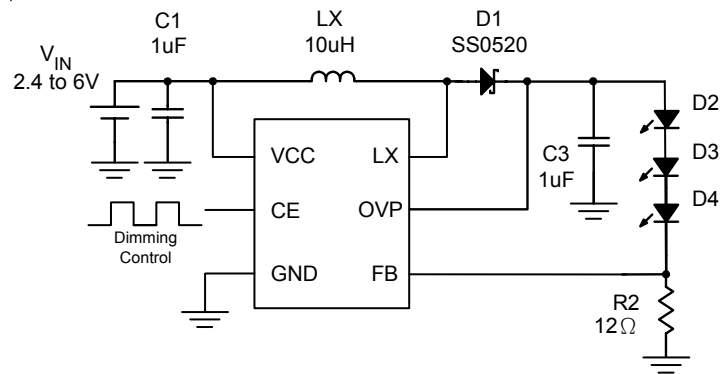

Figure 3. RT9271 Drivers 3 Series WLEDs Application Circuit

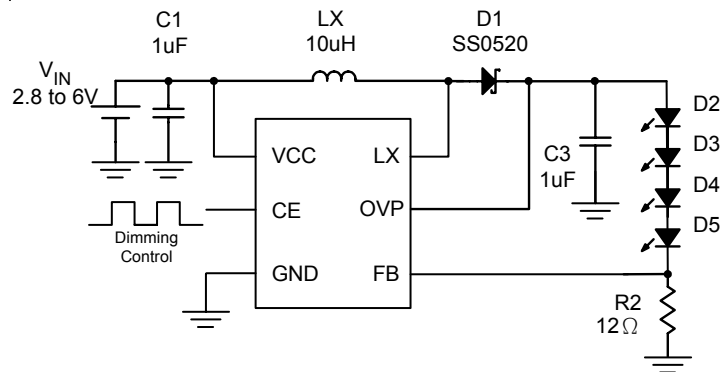

Figure 4. RT9271 Drivers 4 Series WLEDs Application Circuit

- Note :
1. D1 is Schottky diode (SS0520).
 2. D2 ~ D5 are the WLED (HT-S91CW-DT) of HARVATEK.
 3. LX is the SH4018 series of ABC TAIWAN ELECTRONICS CORP.

Recommended Circuits for Driving LED's

Figure 1 to Figure 4 illustrates the recommended application circuits for driving white LED's. The series connected LED's are driven with identical current to emit uniform luminescence, and the 250mV low reference voltage can minimize the efficiency loss across the current-sensing resistor. The recommended current setting for driving white LED's is 10mA to 20mA, and the dimming control can be implemented by toggling CE pin with 60Hz to 1KHz PWM clock. Please refer to application notes for guidance of component selection and board layout.

Absolute Maximum Ratings (Note 1)

- Supply Voltage, V_{CC} ----- -0.3V to 7V
- LX, OVP ----- -0.3V to 21V
- The Other Pins ----- -0.3V to 7V
- Maximum Junction Temperature ----- 125°C
- Lead Temperature (Soldering, 10 sec.) ----- 260°C
- Storage Temperature Range ----- -65°C to 150°C
- ESD Susceptibility (Note 2)
 - HBM ----- 2kV
 - MM ----- 200V

Recommended Operating Conditions (Note 3)

- Supply Voltage, V_{CC} ----- 2.4V to 6V
- Ambient Temperature Range ----- -40°C to 85°C

Electrical Characteristics

($V_{CC} = 3.6V$, $T_A = 25^\circ C$, unless otherwise specified.)

Parameter	Symbol	Test Condition	Min	Typ	Max	Units
System Supply Input						
Under Voltage Lock Out	UVLO		1.8	2.2	2.3	V
Maximum Output Voltage			--	--	20	V
Supply Current	I_{CC1}	$V_{CC}=6V$, Continuously Switching	--	--	2	mA
Quiescent Current	I_{CC2}	$V_{CC}=6V$, FB=1.3V, No Switching	50	90	120	μA
Shut Down Current	I_{CC3}	$V_{CC}=6V$, $V_{CE}<0.4V$	--	0.1	1	μA
Oscillator						
Operation Frequency	F_{OSC}		0.9	1.1	1.3	MHz
Maximum Duty Cycle	Dmax		85	90	--	%
Reference Voltage						
Feedback Voltage	V_{FB}		0.237	0.25	0.263	V
MOSFET						
On Resistance of MOSFET	$R_{ds(on)}$		0.5	0.75	1.0	Ω
Current Limitation	I_{max1}	Normal Operation	600	750	900	mA
Current Limit	I_{max2}	Start up Condition	250	400	550	mA
Control and Protection						
Shut Down Voltage	V_{CE1}		0.4	0.8	--	V
Enable Voltage	V_{CE2}		--	0.8	1.4	V
CE Pin Pull Low Current	I_{CE}		--	4	6	μA
OVP Threshold (Note 4)	OVP		14.5	15.5	20.0	V

Note 1. Stresses beyond those listed under "Absolute Maximum Ratings" may cause permanent damage to the device. These are stress ratings only, and functional operation of the device at these or any other conditions beyond those indicated in the operational sections of the specifications is not implied. Exposure to absolute maximum rating conditions for extended periods may affect device reliability.

Note 2. Devices are ESD sensitive. Handling precaution recommended. The human body model is a 100pF capacitor discharged through a 1.5kΩ resistor into each pin.

Note 3. The device is not guaranteed to function outside its operating conditions.

Note 4. Floating the OVP pin to disable OVP function.

Function Block Diagram

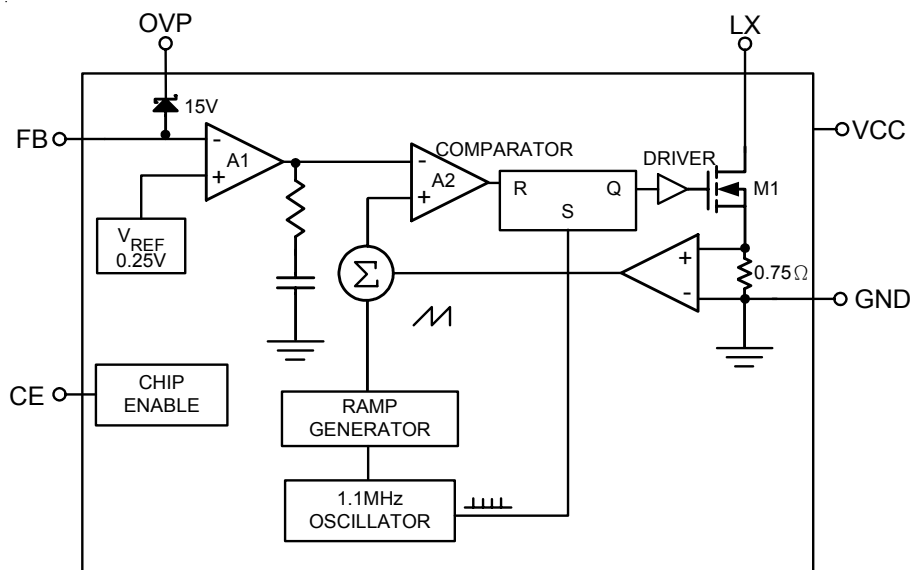

Operation

The RT9271 uses a constant frequency, current mode control scheme to provide excellent line and load regulation. Operation can be best understood by referring to the block diagram. At the start of each oscillator cycle, the SR latch is set, which turns on the power switch M1. A voltage proportional to the switch current is added to a stabilizing ramp and the resulting sum is fed into the positive terminal of the PWM comparator A2. When this voltage exceeds the level at the negative input of A2, the SR latch is reset turning off the power switch. The level at the negative input of A2 is set by the error amplifier A1, and is simply an amplified version of the difference between the feedback voltage and the reference voltage of 250mV. In this manner, the error amplifier sets the correct peak current level to keep the output in regulation. If the error amplifier's output increases, more current is delivered to the output; if it decreases, less current is delivered. A 15V Zener diode connects OVP pin to FB pin internally to provide an optional protection function preventing LX pin from over-voltage damage, in case the feedback loop broken due to component wear-out or improper connection on the application boards. This function is especially suitable for applications driving white LED's less than 4 in series

Typical Operating Characteristics

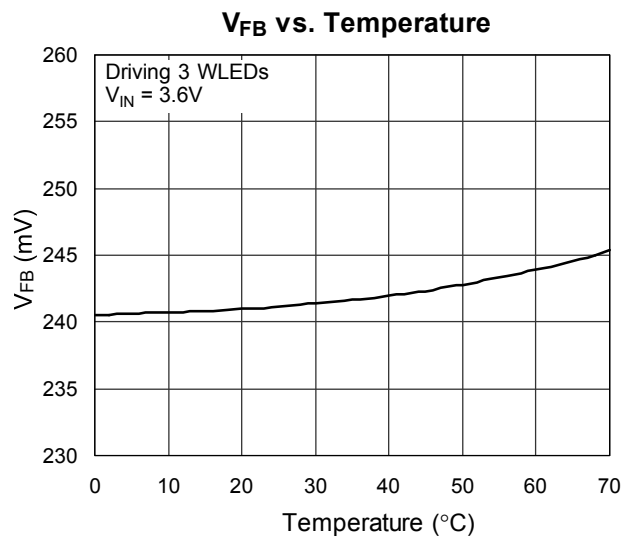
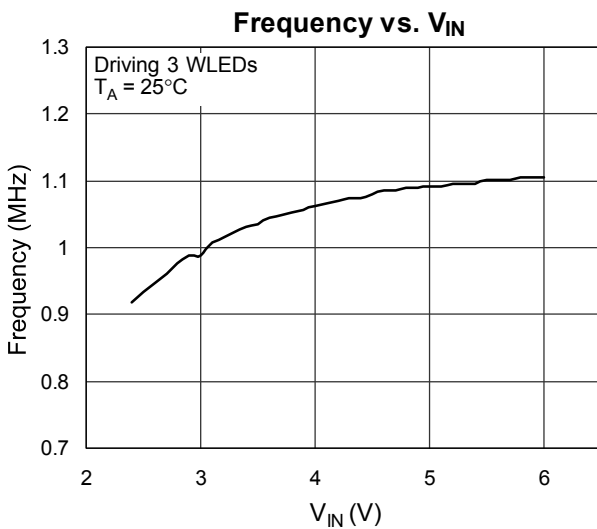
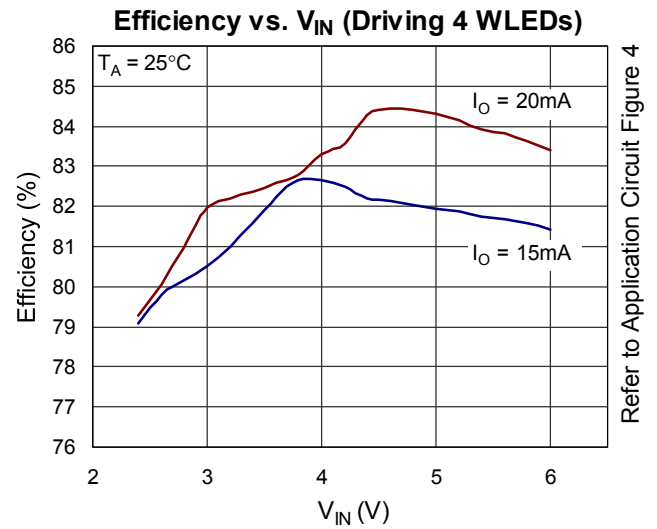
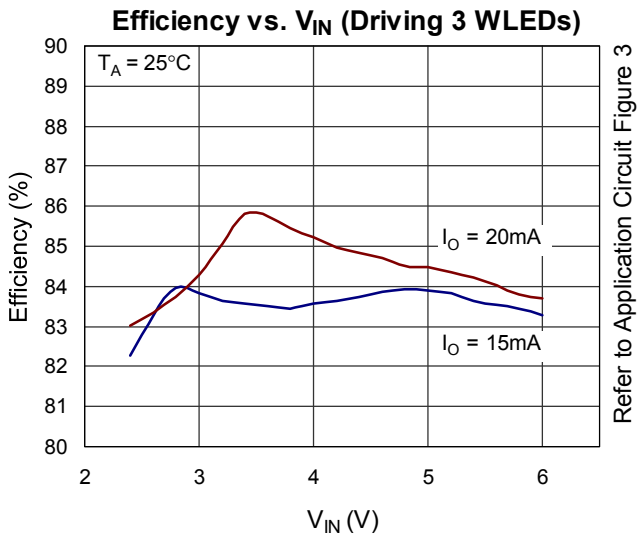
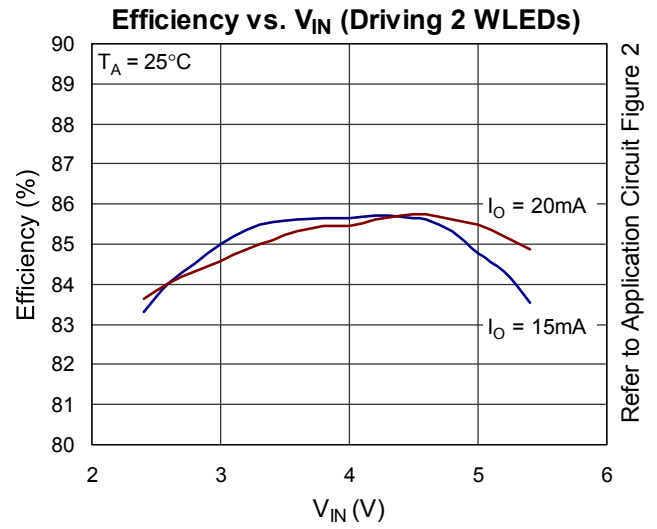
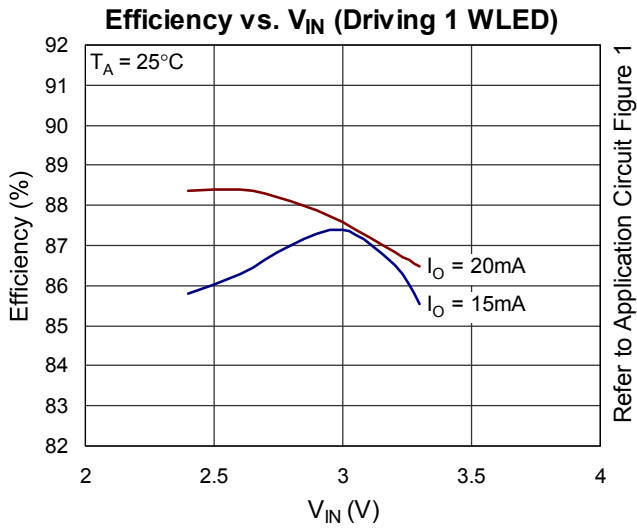

V_{IN} vs. Temperature

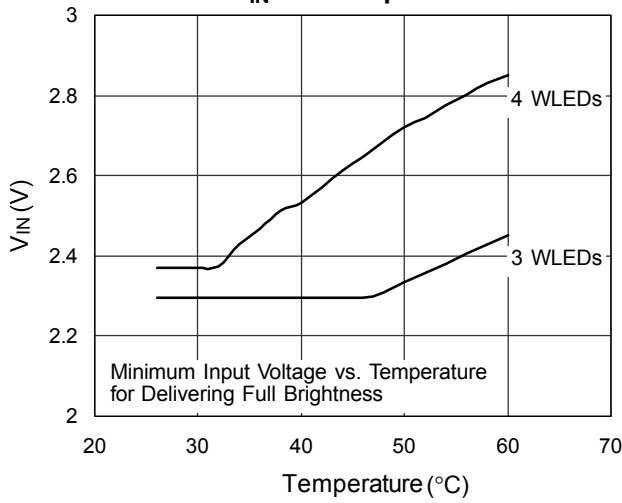

Stability for Driving 1 WLED

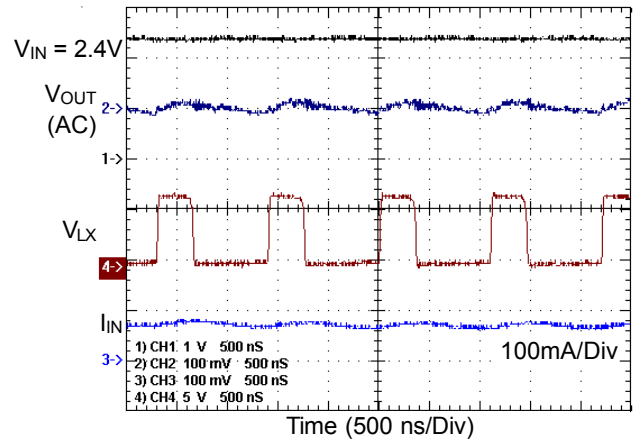

Refer to Application Circuit Figure 1

Stability for Driving 1 WLED

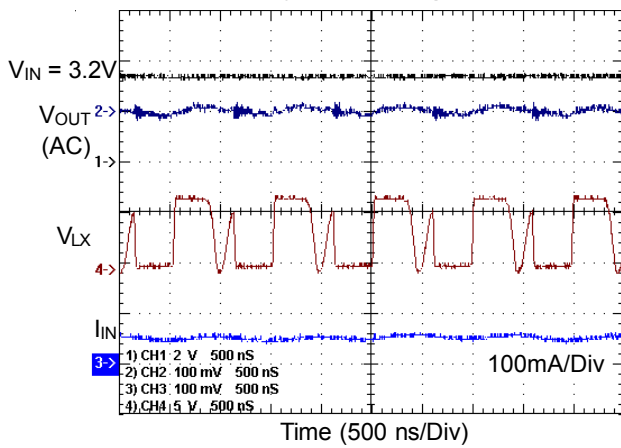

Refer to Application Circuit Figure 1

Stability for Driving 2 WLEDs

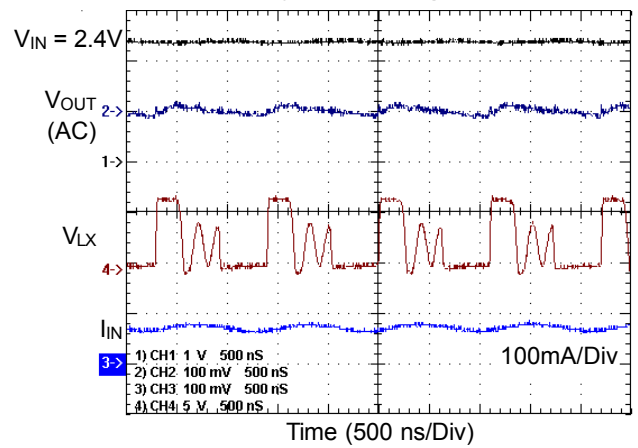

Refer to Application Circuit Figure 2

Stability for Driving 2 WLEDs

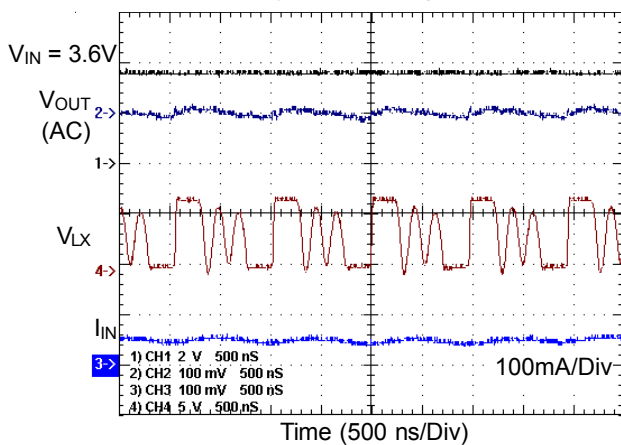

Refer to Application Circuit Figure 2

Stability for Driving 2 WLEDs

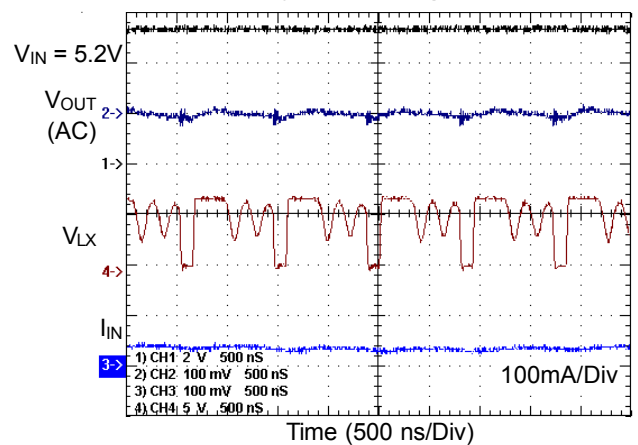

Refer to Application Circuit Figure 2

Stability for Driving 3 WLEDs

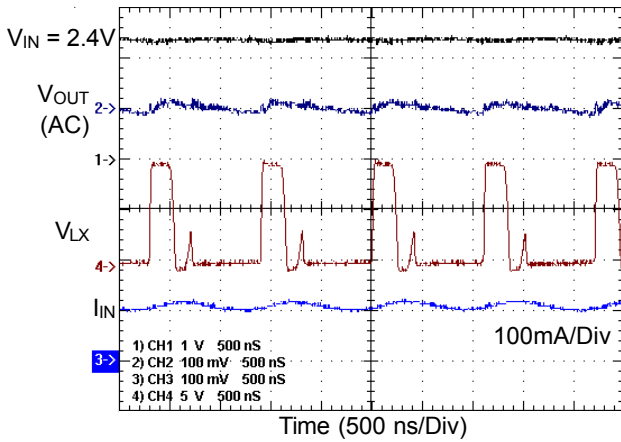

Refer to Application Circuit Figure 3

Stability for Driving 3 WLEDs

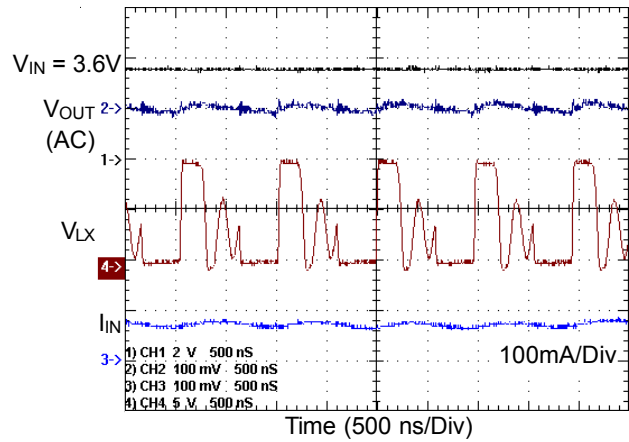

Refer to Application Circuit Figure 3

Stability for Driving 3 WLEDs

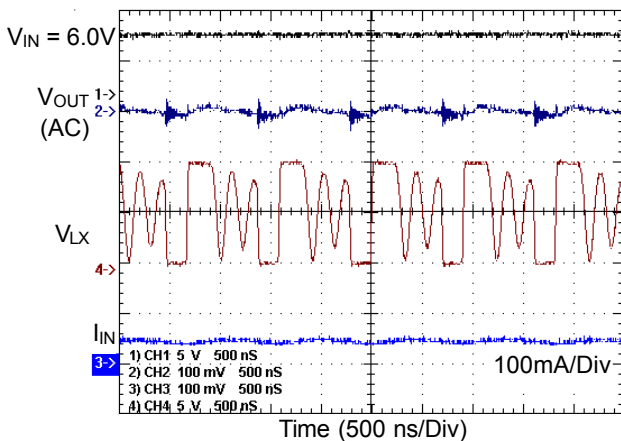

Refer to Application Circuit Figure 3

Stability for Driving 4 WLEDs

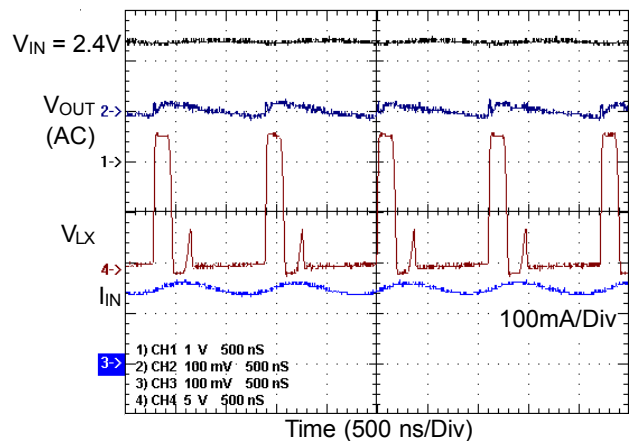

Refer to Application Circuit Figure 4

Stability for Driving 4 WLEDs

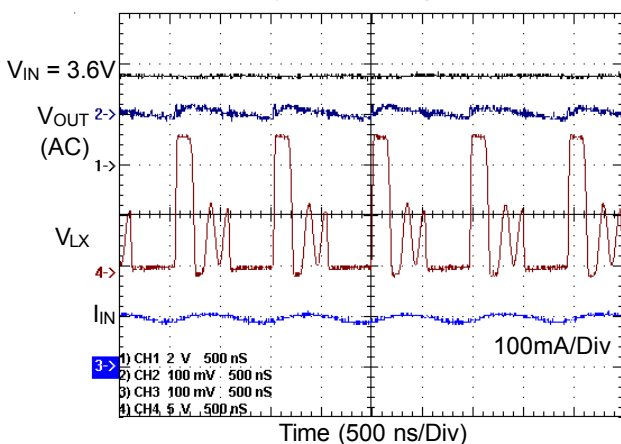

Refer to Application Circuit Figure 4

Stability for Driving 4 WLEDs

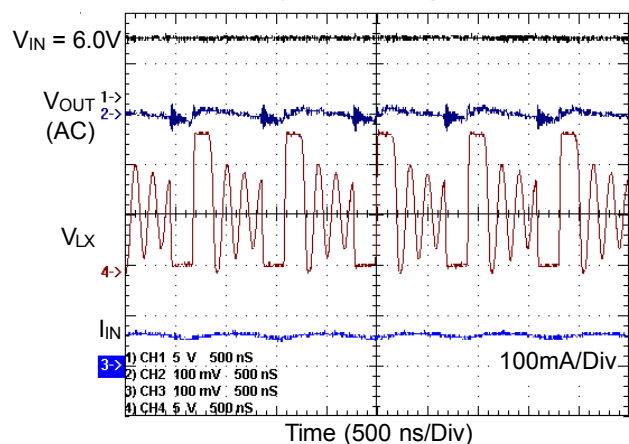

Refer to Application Circuit Figure 4

Inrush Current for Driving 1 WLED

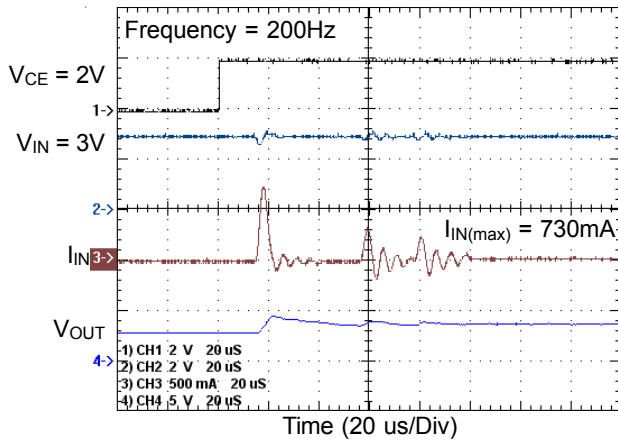

Refer to Application Circuit Figure 1

Inrush Current for Driving 2 WLEDs

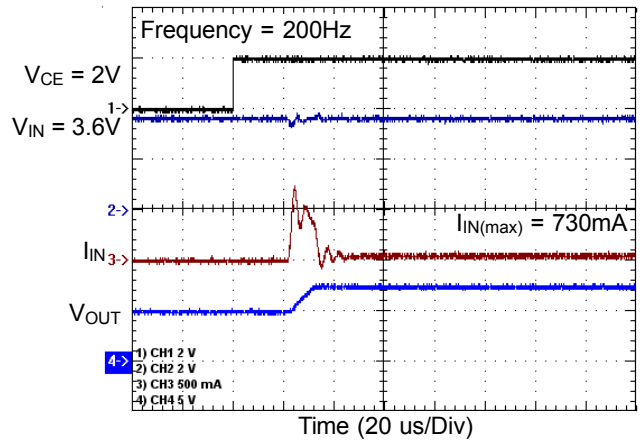

Refer to Application Circuit Figure 2

Inrush Current for Driving 3 WLEDs

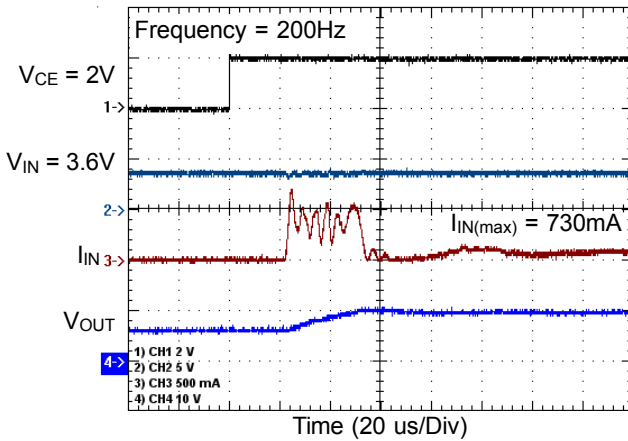

Refer to Application Circuit Figure 3

Inrush Current for Driving 4 WLEDs

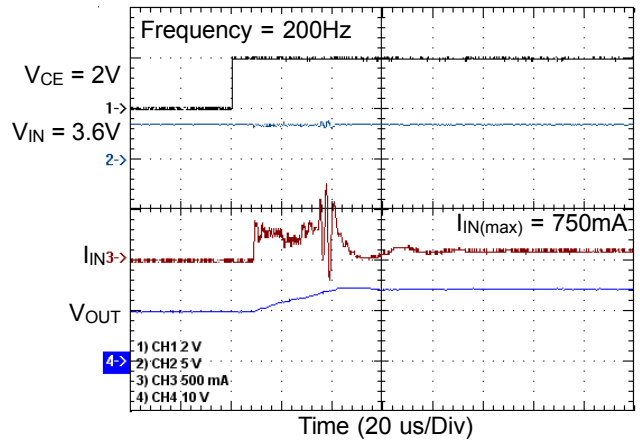

Refer to Application Circuit Figure 4

Inrush Current for Driving 3 WLEDs with soft-start

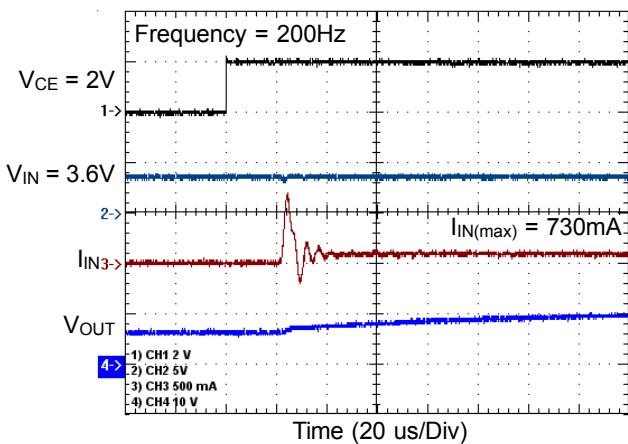

Refer to Application Circuit Figure 3

Dimming Control for Driving 4 WLEDs

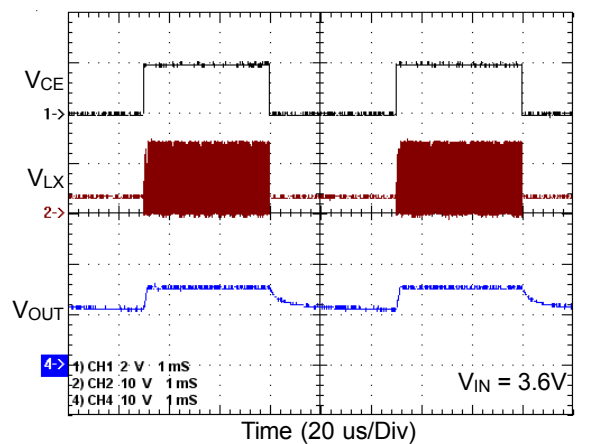

Refer to Application Circuit Figure 4

Application Information

LED Current Control

The LED current is controlled by the feedback resistor (R2 in Application Circuit). The feedback reference is 0.25V. The LED current is $0.25V/R2$. In order to have accurate LED current, precision resistors are preferred (1% is recommended). The formula and table for R2 selection are shown below.

$$R2 = 0.25V / I_{LED}$$

R2 Resistor Value Selection

I _{LED} (mA)	R2 (Ω)
5	49.9
10	24.9
12	21
15	16.5
20	12.4

Recommended Inductance and Rectifier (for Li-Ion cell)

Condition	Inductance (H)	Schottky Diode
2 WLEDs	4.7u~10u	SS0520
3 WLEDs	4.7u~10u	SS0520
4 WLEDs	4.7u~10u	SS0520

Dimming Control

a. Using a PWM Signal to CE Pin

With the PWM signal applied to the CE pin, the RT9271 is turned on or off by the PWM signal. The average LED current increases proportionally with the duty cycle of the PWM signal, A 0% duty cycle will turn off the RT9271 and corresponds to zero LED current. A 100% duty cycle corresponds to full current. The magnitude of the PWM signal should be higher than minimum CE voltage high.

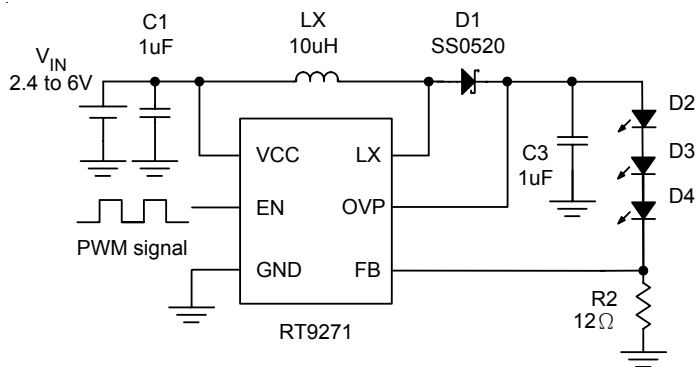

Figure 5. PWM Dimming Control Using the CE Pin

b. Using a DC Voltage

For some applications, the preferred method of brightness control is a variable DC voltage to adjust the LED current. The dimming control using a DC voltage is shown in Figure 6. As the DC voltage increases, the voltage drop on R2 increases and the voltage drop on R1 decreases. Thus, the LED current decreases. For V_{DC} range from 0V to 2.6V, the selection of resistors in Figure 6 gives dimming control of LED current from 20mA to 0mA.

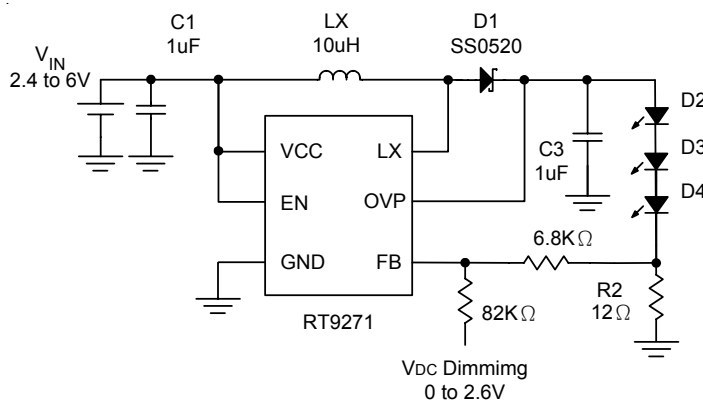

Figure 6. Dimming Control Using a DC Voltage

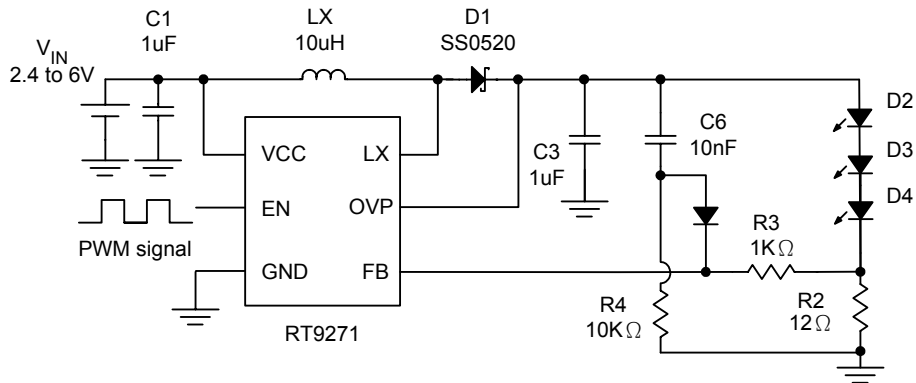
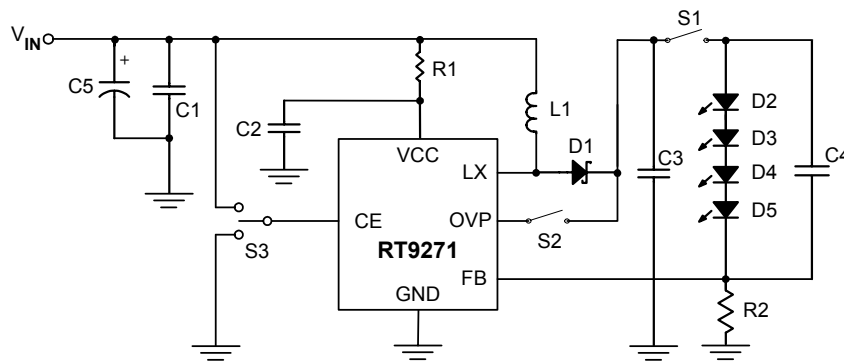

Figure 7. Recommended Soft-Start Circuit

Layout Guide

- A full GND plane without gap break.
- V_{CC} to GND noise bypass – Short and wide connection for the 1μF MLCC capacitor between Pin6 and Pin2.
- Minimized LX node copper area to reduce EMI.
- Minimized FB node copper area and keep far away from noise sources.



EVB Circuit

Board Layout Example (2-Layer EVB Board)

(Refer to EVB Circuit)

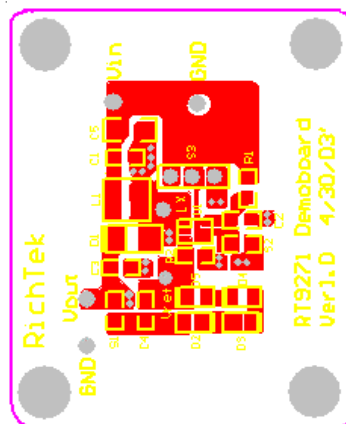

- Top Layer -

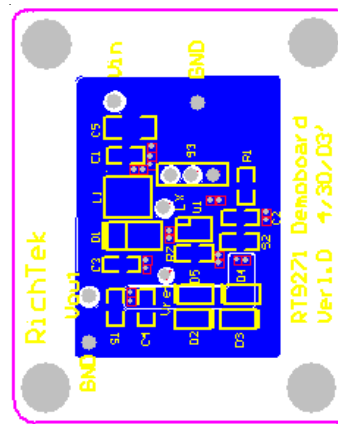

- Bottom Layer -

Outline Dimension

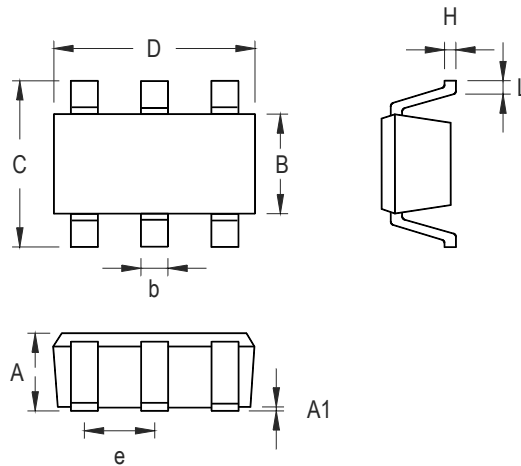

Symbol	Dimensions In Millimeters		Dimensions In Inches	
	Min	Max	Min	Max
A	0.889	1.295	0.035	0.051
A1	--	0.152	--	0.006
B	1.397	1.803	0.055	0.071
b	0.356	0.559	0.014	0.022
C	2.591	2.997	0.102	0.118
D	2.692	3.099	0.106	0.122
e	0.838	1.041	0.033	0.041
H	0.102	0.254	0.004	0.010
L	0.356	0.610	0.014	0.024

SOT- 26 Surface Mount Package

RICHTEK TECHNOLOGY CORP.

Headquarter
 5F, No. 20, Taiyuen Street, Chupei City
 Hsinchu, Taiwan, R.O.C.
 Tel: (8863)5526789 Fax: (8863)5526611

RICHTEK TECHNOLOGY CORP.

Taipei Office (Marketing)
 8F-1, No. 137, Lane 235, Paochiao Road, Hsintien City
 Taipei County, Taiwan, R.O.C.
 Tel: (8862)89191466 Fax: (8862)89191465
 Email: marketing@richtek.com