Document Title

128Kx36 & 256Kx18-Bit Synchronous Burst SRAM

Revision History

<u>Rev. No.</u>	<u>History</u>	<u>Draft Date</u>	<u>Remark</u>
0.0	1. Initial draft	May. 15. 2001	Preliminary
0.1	1. Changed DC parameters Icc ; from 300mA to 250mA at -65, from 280mA to 230mA at -75, from 260mA to 210mA at -80, from 240mA to 190mA at -90, Icc ; from 140mA to 130mA at -65, from 130mA to 120mA at -75, from 120mA to 110mA at -80, from 110mA to 100mA at -90, IsB1 ; from 100mA to 80mA	June. 12. 2001	Preliminary
0.2	1. Add x32 org. and industrial temperature	Aug. 11. 2001	Preliminary
1.0	1. Final spec release 2. Changed Pin Capacitance - Cin ; from 5pF to 4pF - Cout ; from 7pF to 6pF	Nov. 15. 2001	Final
2.0	1. Remove x32 organization 2. Remove -80 speed bin	Nov. 17. 2003	Final
3.0	1. Add the lead-free package type	May 31, 2005	Final

The attached data sheets are prepared and approved by SAMSUNG Electronics. SAMSUNG Electronics CO., LTD. reserve the right to change the specifications. SAMSUNG Electronics will evaluate and reply to your requests and questions on the parameters of this device. If you have any questions, please contact the SAMSUNG branch office near your office, call or contact Headquarters.

4Mb SB/SPB Synchronous SRAM Ordering Information

Org.	Part Number	Mode	VDD	Speed FT ; Access Time(ns) Pipelined ; Cycle Time(MHz)	PKG	Temp
256Kx18	K7B401825B-Q(P)C(I)65/75	SB	3.3	6.5/7.5 ns	Q (100TQFP) P (Lead-Free 100TQFP)	C (Commercial Temperature Range) I: (Industrial Temperature Range)
	K7A401800B-Q(P)C(I)16/14	SPB(2E1D)	3.3	167/138 MHz		
	K7A401809B-Q(P)C(I)25/20	SPB(2E1D)	3.3	250/200 MHz		
128Kx32	K7A403200B-Q(P)C(I)16/14	SPB(2E1D)	3.3	167/138 MHz		
	K7A403209B-Q(P)C(I)25/20	SPB(2E1D)	3.3	250/200 MHz		
128Kx36	K7B403625B-Q(P)C(I)65/75	SB	3.3	6.5/7.5 ns		
	K7A403600B-Q(P)C(I)16/14	SPB(2E1D)	3.3	167/138 MHz		
	K7A403609B-Q(P)C(I)25/20	SPB(2E1D)	3.3	250/200 MHz		

128Kx36 & 256Kx18-Bit Synchronous Burst SRAM

FEATURES

- Synchronous Operation.
- On-Chip Address Counter.
- Write Self-Timed Cycle.
- On-Chip Address and Control Registers.
- $V_{DD} = 3.3V \pm 0.3V / -0.165V$ Power Supply.
- V_{DDQ} Supply Voltage $3.3V \pm 0.3V / -0.165V$ for 3.3V I/O or $2.5V \pm 0.4V / -0.125V$ for 2.5V I/O.
- 5V Tolerant Inputs except I/O Pins.
- Byte Writable Function.
- Global Write Enable Controls a full bus-width write.
- Power Down State via ZZ Signal.
- Asynchronous Output Enable Control.
- \overline{ADSP} , \overline{ADSC} , \overline{ADV} Burst Control Pins.
- LBO Pin allows a choice of either a interleaved burst or a linear burst.
- Three Chip Enables for simple depth expansion with No Data Contention.
- TTL-Level Three-State Output.
- 100-TQFP-1420A (Lead and Lead-Free package)
- Operating in commercial and industrial temperature range.

FAST ACCESS TIMES

PARAMETER	Symbol	-65	-75	Unit
Cycle Time	t _{CYC}	7.5	8.5	ns
Clock Access Time	t _{CD}	6.5	7.5	ns
Output Enable Access Time	t _{OE}	3.5	3.5	ns

GENERAL DESCRIPTION

The K7B403625B and K7B401825B are 4,718,592 bits Synchronous Static Random Access Memory designed to support zero wait state performance for advanced Pentium/Power PC based system. And with $\overline{CS1}$ high, \overline{ADSP} is blocked to control signals.

It can be organized as 128K(256K) words of 36(18) bits. And it integrates address and control registers, a 2-bit burst address counter and high output drive circuitry onto a single integrated circuit for reduced components counts implementation of high performance cache RAM applications.

Write cycles are internally self-timed and synchronous.

The self-timed write feature eliminates complex off chip write pulse shaping logic, simplifying the cache design and further reducing the component count.

Burst cycle can be initiated with either the address status processor(\overline{ADSP}) or address status cache controller(\overline{ADSC}) inputs. Subsequent burst addresses are generated internally in the system's burst sequence and are controlled by the burst address advance(\overline{ADV}) input.

ZZ pin controls Power Down State and reduces Stand-by current regardless of CLK.

The K7B403625B and K7B401825B are implemented with SAMSUNG's high performance CMOS technology and is available in a 100pin TQFP package. Multiple power and ground pins are utilized to minimize ground bounce.

LOGIC BLOCK DIAGRAM

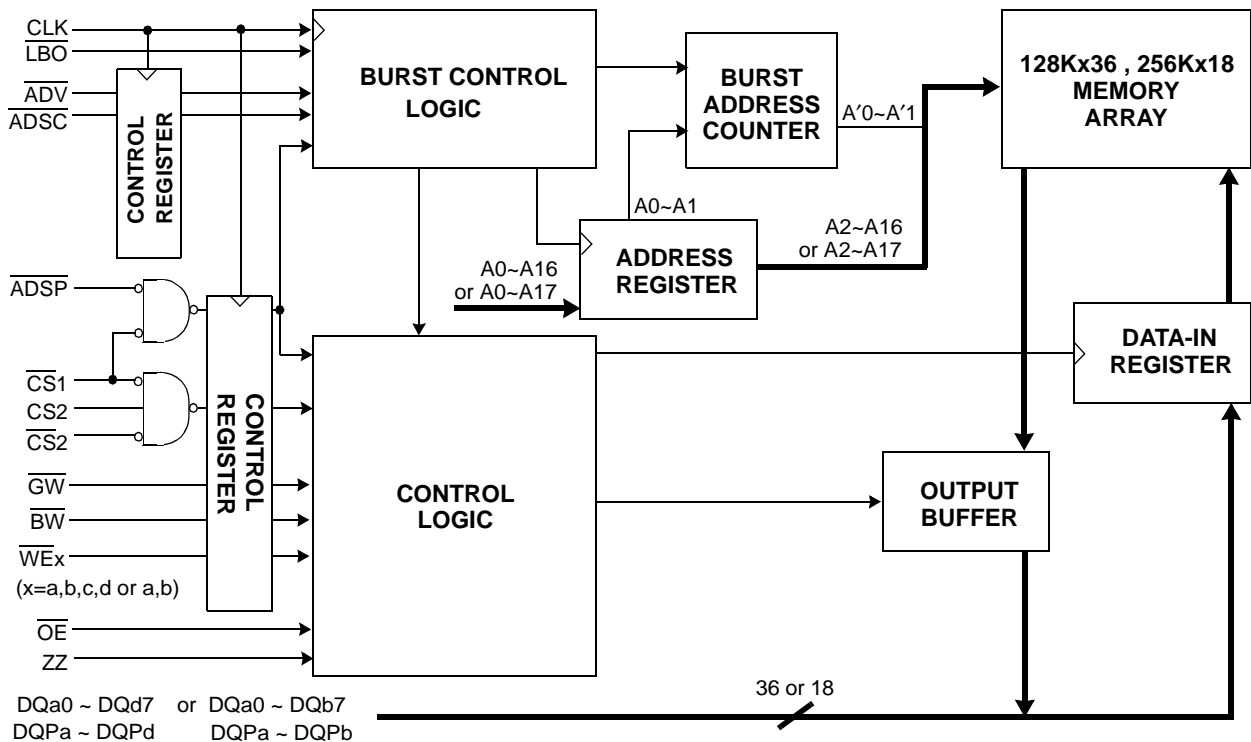

**K7B403625B
K7B401825B**

128Kx36 & 256Kx18 Synchronous SRAM

PIN CONFIGURATION(TOP VIEW)

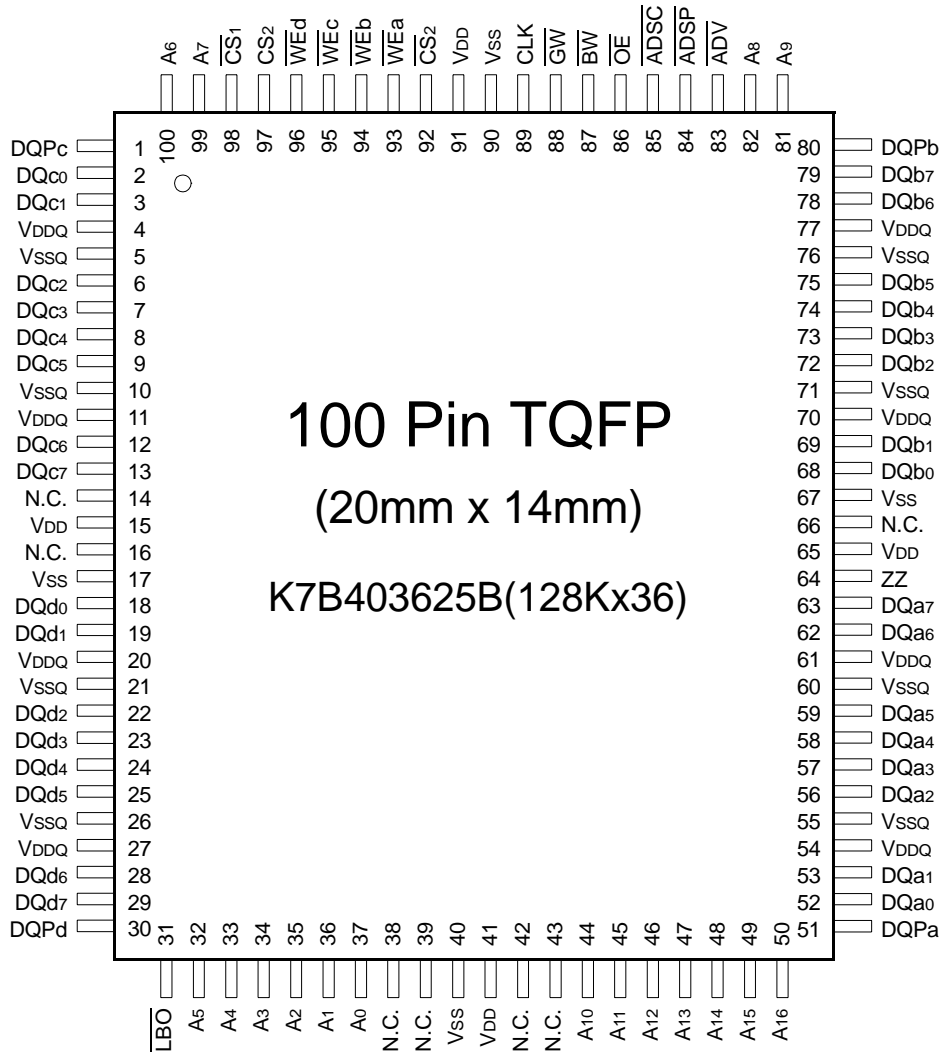

PIN NAME

SYMBOL	PIN NAME	TQFP PIN NO.	SYMBOL	PIN NAME	TQFP PIN NO.
A0 - A16	Address Inputs	32,33,34,35,36,37 44,45,46,47,48,49 50,81,82,99,100	VDD	Power Supply(+3.3V)	15,41,65,91
			VSS	Ground	17,40,67,90
$\overline{\text{ADV}}$	Burst Address Advance	83	N.C.	No Connect	14,16,38,39,42,43,66
$\overline{\text{ADSP}}$	Address Status Processor	84	DQa0~a7	Data Inputs/Outputs	52,53,56,57,58,59,62,63
$\overline{\text{ADSC}}$	Address Status Controller	85	DQb0~b7		68,69,72,73,74,75,78,79
CLK	Clock	89	DQc0~c7		2,3,6,7,8,9,12,13
CS1	Chip Select	98	DQd0~d7		18,19,22,23,24,25,28,29
CS2	Chip Select	97	DQPa~Pd		51,80,1,30
CS2	Chip Select	92			
WEx	Byte Write Inputs	93,94,95,96	VDDQ	Output Power Supply (2.5V or 3.3V)	4,11,20,27,54,61,70,77
(x=a,b,c,d)			VSSQ	Output Ground	5,10,21,26,55,60,71,76
OE	Output Enable	86			
GW	Global Write Enable	88			
BW	Byte Write Enable	87			
ZZ	Power Down Input	64			
LBO	Burst Mode Control	31			

**K7B403625B
K7B401825B**

128Kx36 & 256Kx18 Synchronous SRAM

PIN CONFIGURATION(TOP VIEW)

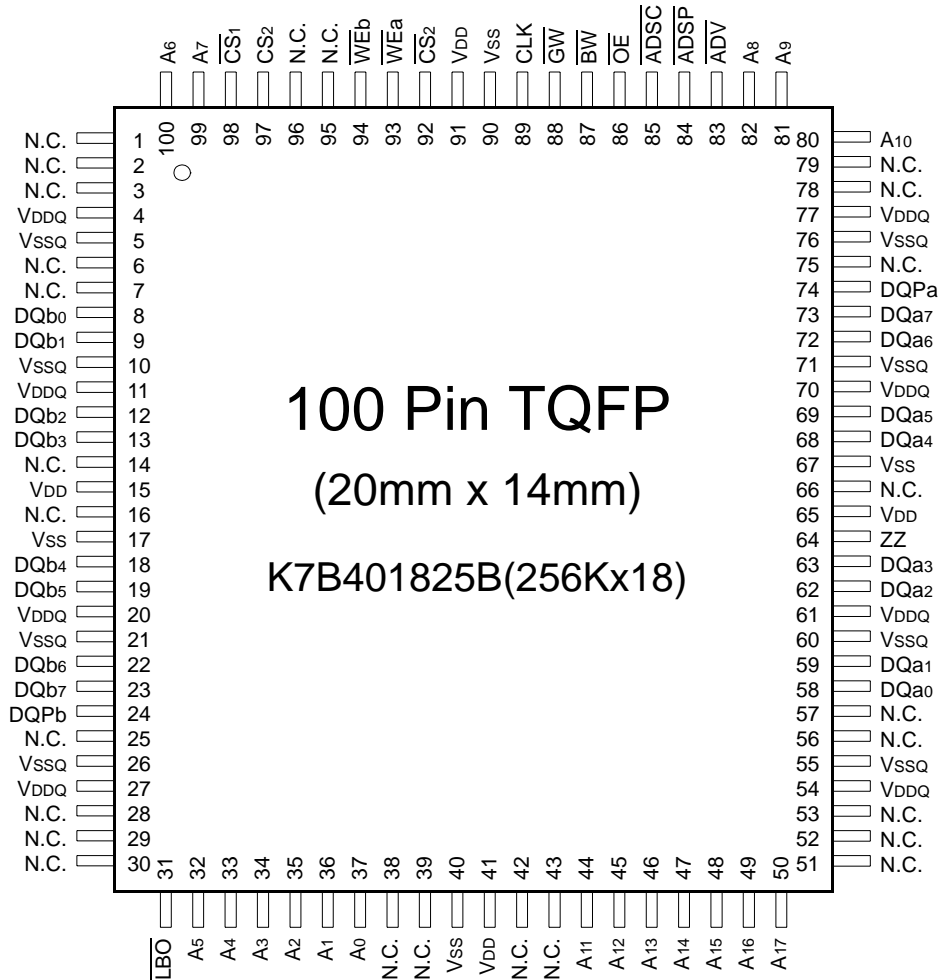

PIN NAME

SYMBOL	PIN NAME	TQFP PIN NO.	SYMBOL	PIN NAME	TQFP PIN NO.
A0 - A17	Address Inputs	32,33,34,35,36,37, 44,45,46,47,48,49, 50,80,81,82,99,100	VDD	Power Supply(+3.3V)	15,41,65,91
			Vss	Ground	17,40,67,90
			N.C.	No Connect	1,2,3,6,7,14,16,25,28,29, 30,38,39,42,43,51,52,53, 56,57,66,75,78,79,95,96
\overline{ADV}	Burst Address Advance	83			
\overline{ADSP}	Address Status Processor	84	DQa0~a7	Data Inputs/Outputs	58,59,62,63,68,69,72,73
\overline{ADSC}	Address Status Controller	85	DQb0~b7		8,9,12,13,18,19,22,23
CLK	Clock	89	DQPa, Pb		74,24
$\overline{CS1}$	Chip Select	98	VDDQ	Output Power Supply (2.5V or 3.3V)	4,11,20,27,54,61,70,77
$\overline{CS2}$	Chip Select	97	Vssq	Output Ground	5,10,21,26,55,60,71,76
$\overline{CS2}$	Chip Select	92			
\overline{WEx}	Byte Write Inputs	93,94			
(x=a,b)					
\overline{OE}	Output Enable	86			
GW	Global Write Enable	88			
BW	Byte Write Enable	87			
ZZ	Power Down Input	64			
LBO	Burst Mode Control	31			

FUNCTION DESCRIPTION

The K7B403625B and K7B401825B are synchronous SRAM designed to support the burst address accessing sequence of the Pentium and Power PC based microprocessor. All inputs (with the exception of \overline{OE} , \overline{LBO} and \overline{ZZ}) are sampled on rising clock edges. The start and duration of the burst access is controlled by \overline{ADSC} , \overline{ADSP} and \overline{ADV} and chip select pins.

When \overline{ZZ} is pulled high, the SRAM will enter a Power Down State. At this time, internal state of the SRAM is preserved. When \overline{ZZ} returns to low, the SRAM normally operates after 2cycles of wake up time. \overline{ZZ} pin is pulled down internally.

Read cycles are initiated with \overline{ADSP} (or \overline{ADSC}) using the new external address clocked into the on-chip address register when both \overline{GW} and \overline{BW} are high or when \overline{BW} is low and \overline{WEa} , \overline{WEb} , \overline{WEc} , and \overline{WEd} are high. When \overline{ADSP} is sampled low, the chip selects are sampled active, and the output buffer is enabled with \overline{OE} . the data of cell array accessed by the current address are projected to the output pins.

Write cycles are also initiated with \overline{ADSP} (or \overline{ADSC}) and are differentiated into two kinds of operations; All byte write operation and individual byte write operation.

All byte write occurs by enabling \overline{GW} (independent of \overline{BW} and \overline{WEx} .), and individual byte write is performed only when \overline{GW} is high and \overline{BW} is low. In K7B403625B, a 128Kx36 organization, \overline{WEa} controls DQa0 ~ DQa7 and DQPa, \overline{WEb} controls DQb0 ~ DQb7 and DQPb, \overline{WEc} controls DQc0 ~ DQc7 and DQPc and \overline{WEd} controls DQd0 ~ DQd7 and DQPd.

$\overline{CS1}$ is used to enable the device and conditions internal use of \overline{ADSP} and is sampled only when a new external address is loaded.

\overline{ADV} is ignored at the clock edge when \overline{ADSP} is asserted, but can be sampled on the subsequent clock edges. The address increases internally for the next access of the burst when \overline{ADV} is sampled low.

Addresses are generated for the burst access as shown below, The starting point of the burst sequence is provided by the external address. The burst address counter wraps around to its initial state upon completion. The burst sequence is determined by the state of the \overline{LBO} pin. When this pin is Low, linear burst sequence is selected. And this pin is High, Interleaved burst sequence is selected.

BURST SEQUENCE TABLE

(Interleaved Burst)

\overline{LBO} PIN	HIGH	Case 1		Case 2		Case 3		Case 4	
		A1	A0	A1	A0	A1	A0	A1	A0
	First Address	0	0	0	1	1	0	1	1
	↓	0	1	0	0	1	1	1	0
	Fourth Address	1	0	1	1	0	0	0	1
		1	1	1	0	0	1	0	0

Note : 1. \overline{LBO} pin must be tied to high or low, and floating state must not be allowed.

(Linear Burst)

\overline{LBO} PIN	LOW	Case 1		Case 2		Case 3		Case 4	
		A1	A0	A1	A0	A1	A0	A1	A0
	First Address	0	0	0	1	1	0	1	1
	↓	0	1	1	0	1	1	0	0
	Fourth Address	1	0	1	1	0	0	0	1
		1	1	0	0	0	1	1	0

Note : 1. \overline{LBO} pin must be tied to high or low, and floating state must not be allowed.

ASYNCHRONOUS TRUTH TABLE

(See Notes 1 and 2):

OPERATION	\overline{ZZ}	\overline{OE}	I/O STATUS
Sleep Mode	H	X	High-Z
Read	L	L	DQ
	L	H	High-Z
Write	L	X	Din, High-Z
Deselected	L	X	High-Z

Notes

1. X means "Don't Care".
2. \overline{ZZ} pin is pulled down internally
3. For write cycles that following read cycles, the output buffers must be disabled with \overline{OE} , otherwise data bus contention will occur.
4. Sleep Mode means power down state of which stand-by current does not depend on cycle time.
5. Deselected means power down state of which stand-by current depends on cycle time.

TRUTH TABLES

SYNCHRONOUS TRUTH TABLE

\overline{CS}_1	\overline{CS}_2	\overline{CS}_2	\overline{ADSP}	\overline{ADSC}	\overline{ADV}	\overline{WRITE}	CLK	ADDRESS ACCESSED	OPERATION
H	X	X	X	L	X	X	↑	N/A	Not Selected
L	L	X	L	X	X	X	↑	N/A	Not Selected
L	X	H	L	X	X	X	↑	N/A	Not Selected
L	L	X	X	L	X	X	↑	N/A	Not Selected
L	X	H	X	L	X	X	↑	N/A	Not Selected
L	H	L	L	X	X	X	↑	External Address	Begin Burst Read Cycle
L	H	L	H	L	X	L	↑	External Address	Begin Burst Write Cycle
L	H	L	H	L	X	H	↑	External Address	Begin Burst Read Cycle
X	X	X	H	H	L	H	↑	Next Address	Continue Burst Read Cycle
H	X	X	X	H	L	H	↑	Next Address	Continue Burst Read Cycle
X	X	X	H	H	L	L	↑	Next Address	Continue Burst Write Cycle
H	X	X	X	H	L	L	↑	Next Address	Continue Burst Write Cycle
X	X	X	H	H	H	H	↑	Current Address	Suspend Burst Read Cycle
H	X	X	X	H	H	H	↑	Current Address	Suspend Burst Read Cycle
X	X	X	H	H	H	L	↑	Current Address	Suspend Burst Write Cycle
H	X	X	X	H	H	L	↑	Current Address	Suspend Burst Write Cycle

- Notes :** 1. X means "Don't Care". 2. The rising edge of clock is symbolized by ↑.
 3. $\overline{WRITE} = L$ means Write operation in WRITE TRUTH TABLE.
 $\overline{WRITE} = H$ means Read operation in WRITE TRUTH TABLE.
 4. Operation finally depends on status of asynchronous input pins(ZZ and \overline{OE}).

WRITE TRUTH TABLE(x36)

\overline{GW}	\overline{BW}	\overline{WE}_a	\overline{WE}_b	\overline{WE}_c	\overline{WE}_d	OPERATION
H	H	X	X	X	X	READ
H	L	H	H	H	H	READ
H	L	L	H	H	H	WRITE BYTE a
H	L	H	L	H	H	WRITE BYTE b
H	L	H	H	L	L	WRITE BYTE c and d
H	L	L	L	L	L	WRITE ALL BYTES
L	X	X	X	X	X	WRITE ALL BYTES

- Notes :** 1. X means "Don't Care".
 2. All inputs in this table must meet setup and hold time around the rising edge of CLK(↑).

WRITE TRUTH TABLE(x18)

\overline{GW}	\overline{BW}	\overline{WE}_a	\overline{WE}_b	OPERATION
H	H	X	X	READ
H	L	H	H	READ
H	L	L	H	WRITE BYTE a
H	L	H	L	WRITE BYTE b
H	L	L	L	WRITE ALL BYTES
L	X	X	X	WRITE ALL BYTES

- Notes :** 1. X means "Don't Care".
 2. All inputs in this table must meet setup and hold time around the rising edge of CLK(↑).

ABSOLUTE MAXIMUM RATINGS*

PARAMETER		SYMBOL	RATING	UNIT
Voltage on V _{DD} Supply Relative to V _{SS}		V _{DD}	-0.3 to 4.6	V
Voltage on V _{DDQ} Supply Relative to V _{SS}		V _{DDQ}	V _{DD}	V
Voltage on Input Pin Relative to V _{SS}		V _{IN}	-0.3 to V _{DD} +0.3	V
Voltage on I/O Pin Relative to V _{SS}		V _{IO}	-0.3 to V _{DDQ} +0.3	V
Power Dissipation		P _D	1.4	W
Storage Temperature		T _{STG}	-65 to 150	°C
Operating Temperature	Commercial	T _{OPR}	0 to 70	°C
	Industrial	T _{OPR}	-40 to 85	°C
Storage Temperature Range Under Bias		T _{BIAS}	-10 to 85	°C

*Note : Stresses greater than those listed under "Absolute Maximum Ratings" may cause permanent damage to the device. This is a stress rating only and functional operation of the device at these or any other conditions above those indicated in the operating sections of this specification is not implied. Exposure to absolute maximum rating conditions for extended periods may affect reliability.

OPERATING CONDITIONS at 3.3V I/O (0°C ≤ T_A ≤ 70°C)

PARAMETER	SYMBOL	MIN	Typ.	MAX	UNIT
Supply Voltage	V _{DD}	3.135	3.3	3.6	V
	V _{DDQ}	3.135	3.3	3.6	V
Ground	V _{SS}	0	0	0	V

* The above parameters are also guaranteed at industrial temperature range.

OPERATING CONDITIONS at 2.5V I/O (0°C ≤ T_A ≤ 70°C)

PARAMETER	SYMBOL	MIN	Typ.	MAX	UNIT
Supply Voltage	V _{DD}	3.135	3.3	3.6	V
	V _{DDQ}	2.375	2.5	2.9	V
Ground	V _{SS}	0	0	0	V

* The above parameters are also guaranteed at industrial temperature range.

CAPACITANCE* (T_A=25°C, f=1MHz)

PARAMETER	SYMBOL	TEST CONDITION	TYP	MAX	UNIT
Input Capacitance	C _{IN}	V _{IN} =0V	-	4	pF
Output Capacitance	C _{OUT}	V _{OUT} =0V	-	6	pF

*Note : Sampled not 100% tested.

DC ELECTRICAL CHARACTERISTICS($T_A=0$ to 70°C , $V_{DD}=3.3\text{V}+0.3\text{V}/-0.165\text{V}$)

PARAMETER	SYMBOL	TEST CONDITIONS	MIN	MAX	UNI	
Input Leakage Current(except ZZ)	IIL	$V_{DD}=\text{Max}$, $V_{IN}=V_{SS}$ to V_{DD}	-2	+2	μA	
Output Leakage Current	IOL	Output Disabled, $V_{OUT}=V_{SS}$ to V_{DDQ}	-2	+2	μA	
Operating Current	I _{CC}	Device Selected, I _{OUT} =0mA, ZZ≤V _{IL} , All Inputs=V _{IL} or V _{IH}	-65	-	250	mA
			-75	-	230	
Standby Current	I _{SB}	Device deselected, I _{OUT} =0mA, ZZ≤V _{IL} , f=Max, All Inputs≤0.2V or ≥V _{DD} -0.2V	-65	-	130	mA
			-75	-	120	
	I _{SB1}	Device deselected, I _{OUT} =0mA, ZZ≤0.2V, f=0, All Inputs=fixed (V _{DD} -0.2V or 0.2V)	-	-	80	mA
	I _{SB2}	Device deselected, I _{OUT} =0mA, ZZ≥V _{DD} -0.2V, f=Max, All Inputs≤V _{IL} or ≥V _{IH}	-	-	50	
Output Low Voltage(3.3V I/O)	V _{OL}	I _{OL} = 8.0mA	-	0.4	V	
Output High Voltage(3.3V I/O)	V _{OH}	I _{OH} = -4.0mA	2.4	-	V	
Output Low Voltage(2.5V I/O)	V _{OL}	I _{OL} = 1.0mA	-	0.4	V	
Output High Voltage(2.5V I/O)	V _{OH}	I _{OH} = -1.0mA	2.0	-	V	
Input Low Voltage(3.3V I/O)	V _{IL}		-0.5*	0.8	V	
Input High Voltage(3.3V I/O)	V _{IH}		2.0	V _{DD} +0.3**	V	
Input Low Voltage(2.5V I/O)	V _{IL}		-0.3*	0.7	V	
Input High Voltage(2.5V I/O)	V _{IH}		1.7	V _{DD} +0.3**	V	

The above parameters are also guaranteed at industrial temperature range.

* V_{IL}(Min)=-2.0(Pulse Width ≤ t_{CYC}/2)

** V_{IH}(Max)=4.6(Pulse Width ≤ t_{CYC}/2)

** In Case of I/O Pins, the Max. V_{IH}=V_{DDQ}+0.3V

TEST CONDITIONS

($V_{DD}=3.3\text{V}+0.3\text{V}/-0.165\text{V}$, $V_{DDQ}=3.3\text{V}+0.3\text{V}/-0.165\text{V}$ or $V_{DD}=3.3\text{V}+0.3\text{V}/-0.165\text{V}$, $V_{DDQ}=2.5\text{V}+0.4\text{V}/-0.125\text{V}$, $T_A=0$ to 70°C)

PARAMETER	VALUE
Input Pulse Level(for 3.3V I/O)	0 to 3V
Input Pulse Level(for 2.5V I/O)	0 to 2.5V
Input Rise and Fall Time(Measured at 0.3V and 2.7V for 3.3V I/O)	1ns
Input Rise and Fall Time(Measured at 0.3V and 2.1V for 2.5V I/O)	1ns
Input and Output Timing Reference Levels for 3.3V I/O	1.5V
Input and Output Timing Reference Levels for 2.5V I/O	V _{DDQ} /2
Output Load	See Fig. 1

* The above parameters are also guaranteed at industrial temperature range.

K7B403625B
K7B401825B

128Kx36 & 256Kx18 Synchronous SRAM

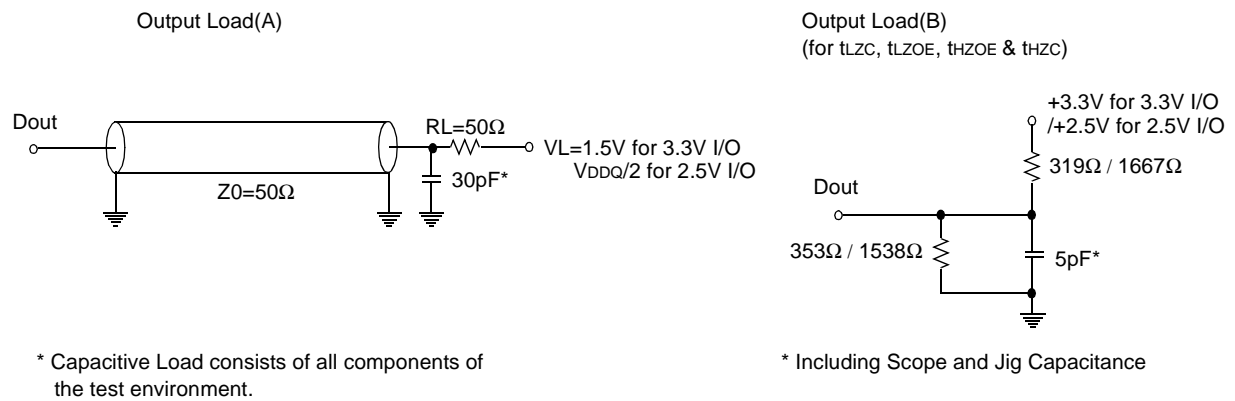

Fig. 1

AC TIMING CHARACTERISTICS($T_A=0$ to 70°C , $V_{DD}=3.3\text{V}+0.3\text{V}/-0.165\text{V}$)

PARAMETER	Symbol	-65		-75		UNIT
		Min	Max	Min	Max	
Cycle Time	tCYC	7.5	-	8.5	-	ns
Clock Access Time	tCD	-	6.5	-	7.5	ns
Output Enable to Data Valid	tOE	-	3.5	-	3.5	ns
Clock High to Output Low-Z	tLZC	0	-	0	-	ns
Output Hold from Clock High	tOH	2.5	-	2.5	-	ns
Output Enable Low to Output Low-Z	tLZOE	0	-	0	-	ns
Output Enable High to Output High-Z	tHZOE	-	3.5	-	3.5	ns
Clock High to Output High-Z	tHZC	2	3.5	2	3.5	ns
Clock High Pulse Width	tCH	2.5	-	3	-	ns
Clock Low Pulse Width	tCL	2.5	-	3	-	ns
Address Setup to Clock High	tAS	1.5	-	2.0	-	ns
Address Status Setup to Clock High	tSS	1.5	-	2.0	-	ns
Data Setup to Clock High	tDS	1.5	-	2.0	-	ns
Write Setup to Clock High($\overline{\text{GW}}$, $\overline{\text{BW}}$, $\overline{\text{WEx}}$)	tWS	1.5	-	2.0	-	ns
Address Advance Setup to Clock High	tADVS	1.5	-	2.0	-	ns
Chip Select Setup to Clock High	tCSS	1.5	-	2.0	-	ns
Address Hold from Clock High	tAH	0.5	-	0.5	-	ns
Address Status Hold from Clock High	tSH	0.5	-	0.5	-	ns
Data Hold from Clock High	tDH	0.5	-	0.5	-	ns
Write Hold from Clock High($\overline{\text{GW}}$, $\overline{\text{BW}}$, $\overline{\text{WEx}}$)	tWH	0.5	-	0.5	-	ns
Address Advance Hold from Clock High	tADVH	0.5	-	0.5	-	ns
Chip Select Hold from Clock High	tCSH	0.5	-	0.5	-	ns
ZZ High to Power Down	tPDS	2	-	2	-	cycle
ZZ Low to Power Up	tPUS	2	-	2	-	cycle

- Notes :**
- 1 The above parameters are also guaranteed at industrial temperature range.
 2. All address inputs must meet the specified setup and hold times for all rising clock edges whenever $\overline{\text{ADSC}}$ and/or $\overline{\text{ADSP}}$ is sampled low and $\overline{\text{CS}}$ is sampled low. All other synchronous inputs must meet the specified setup and hold times whenever this device is chip selected.
 3. Both chip selects must be active whenever $\overline{\text{ADSC}}$ or $\overline{\text{ADSP}}$ is sampled low in order for the this device to remain enabled.
 4. $\overline{\text{ADSC}}$ or $\overline{\text{ADSP}}$ must not be asserted for at least 2 Clock after leaving ZZ state.
 5. At any given voltage and temperature, tHZC is less than tLZC.

TIMING WAVEFORM OF READ CYCLE

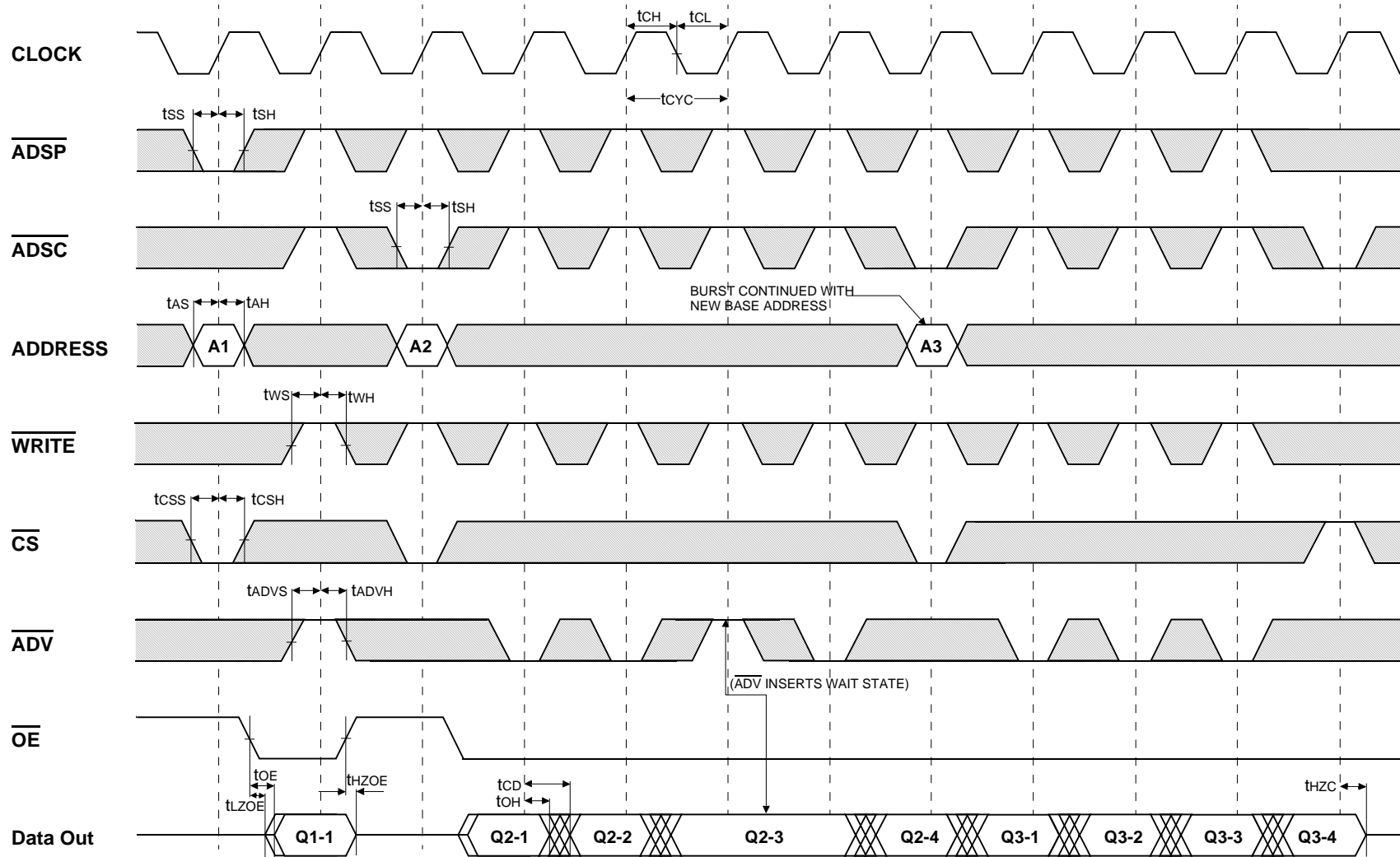

NOTES : $\overline{\text{WRITE}} = \text{L}$ means $\overline{\text{GW}} = \text{L}$, or $\overline{\text{GW}} = \text{H}$, $\overline{\text{BW}} = \text{L}$, $\overline{\text{WEx}} = \text{L}$
 $\overline{\text{CS}} = \text{L}$ means $\overline{\text{CS}}_1 = \text{L}$, $\text{CS}_2 = \text{H}$ and $\overline{\text{CS}}_2 = \text{L}$
 $\overline{\text{CS}} = \text{H}$ means $\overline{\text{CS}}_1 = \text{H}$, or $\overline{\text{CS}}_1 = \text{L}$ and $\text{CS}_2 = \text{H}$, or $\overline{\text{CS}}_1 = \text{L}$, and $\text{CS}_2 = \text{L}$

□ Don't Care
 ⊗ Undefined

K7B403625B
K7B401825B

128Kx36 & 256Kx18 Synchronous SRAM

TIMING WAVEFORM OF WRTE CYCLE

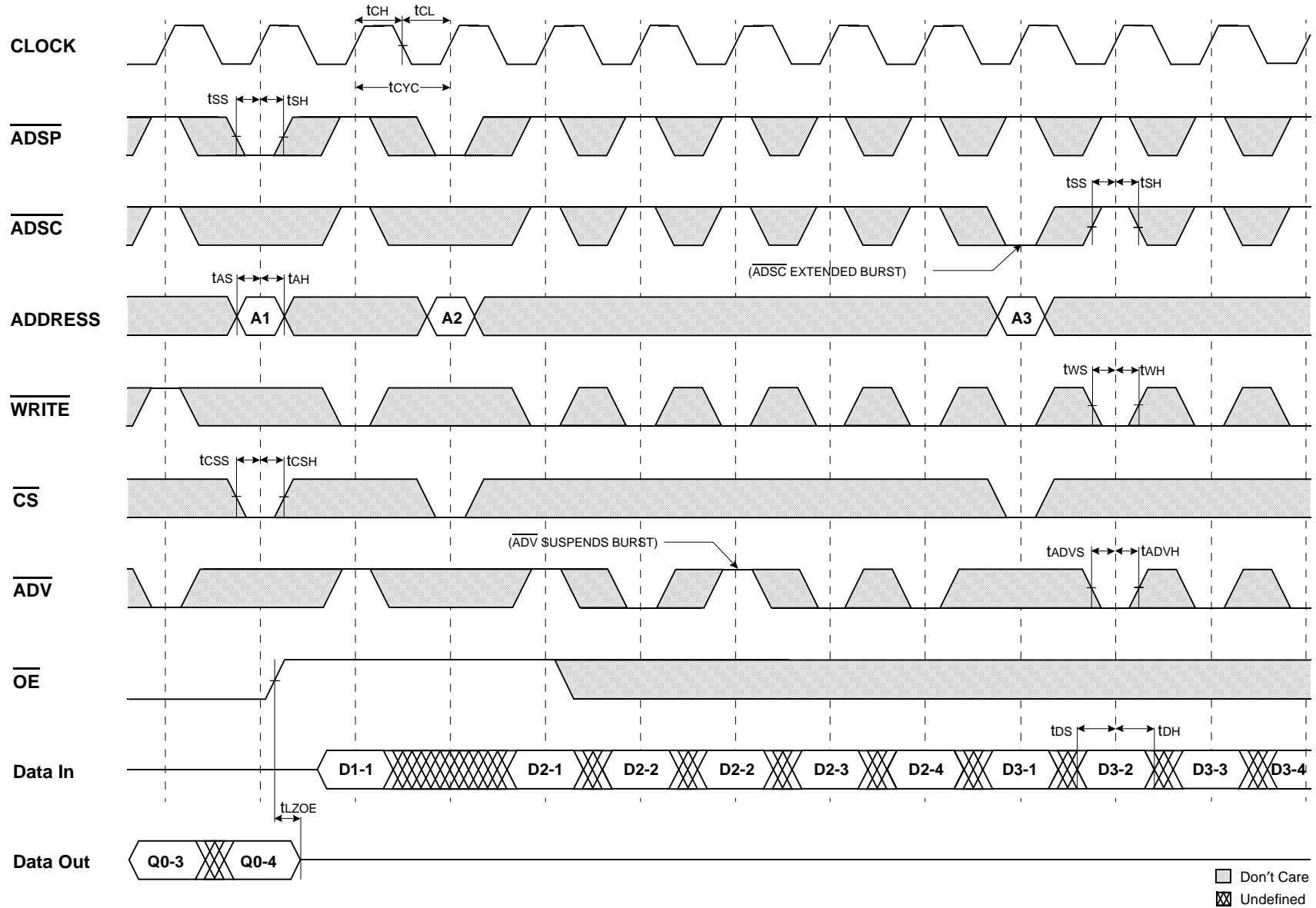

K7B403625B
K7B401825B

128Kx36 & 256Kx18 Synchronous SRAM

TIMING WAVEFORM OF COMBINATION READ/WRITE CYCLE(ADSP CONTROLLED, $\overline{\text{ADSC}}=\text{HIGH}$)

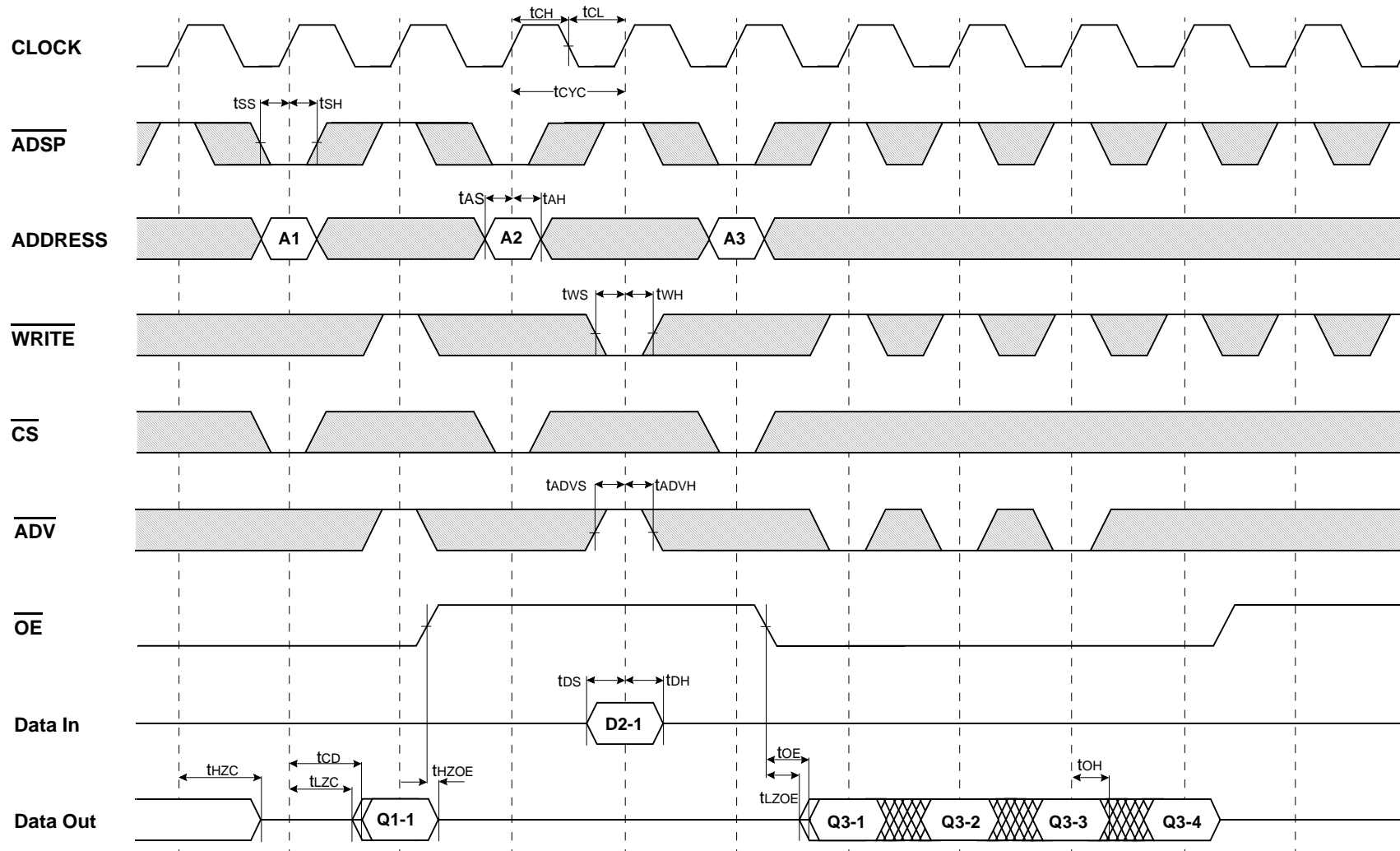

K7B403625B
K7B401825B

128Kx36 & 256Kx18 Synchronous SRAM

TIMING WAVEFORM OF SINGLE READ/WRITE CYCLE(ADSC CONTROLLED, ADSP=HIGH)

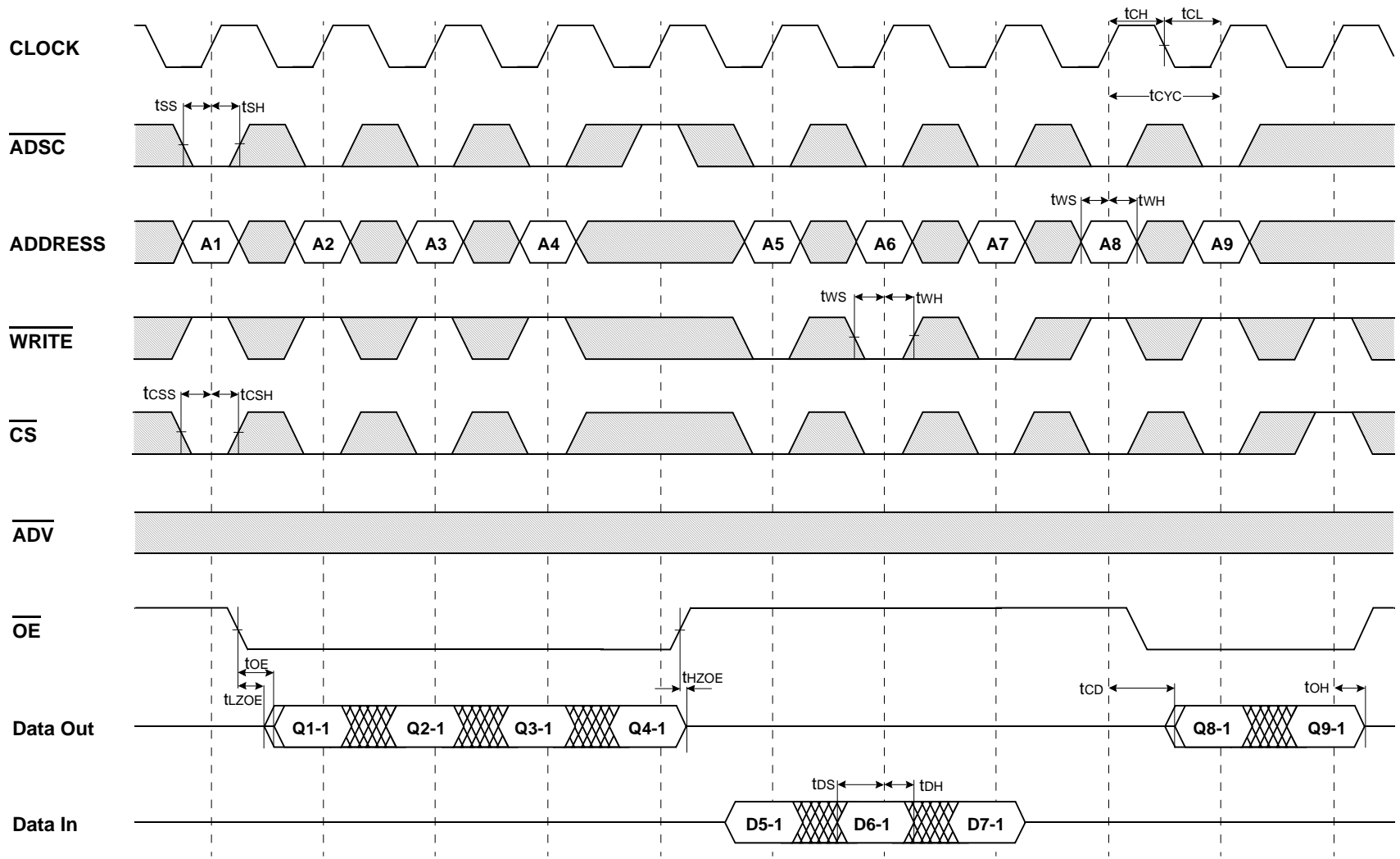

K7B403625B
K7B401825B

128Kx36 & 256Kx18 Synchronous SRAM

□ Don't Care
▣ Undefined

TIMING WAVEFORM OF SINGLE READ/WRITE CYCLE(ADSP CONTROLLED, $\overline{\text{ADSC}}=\text{HIGH}$)

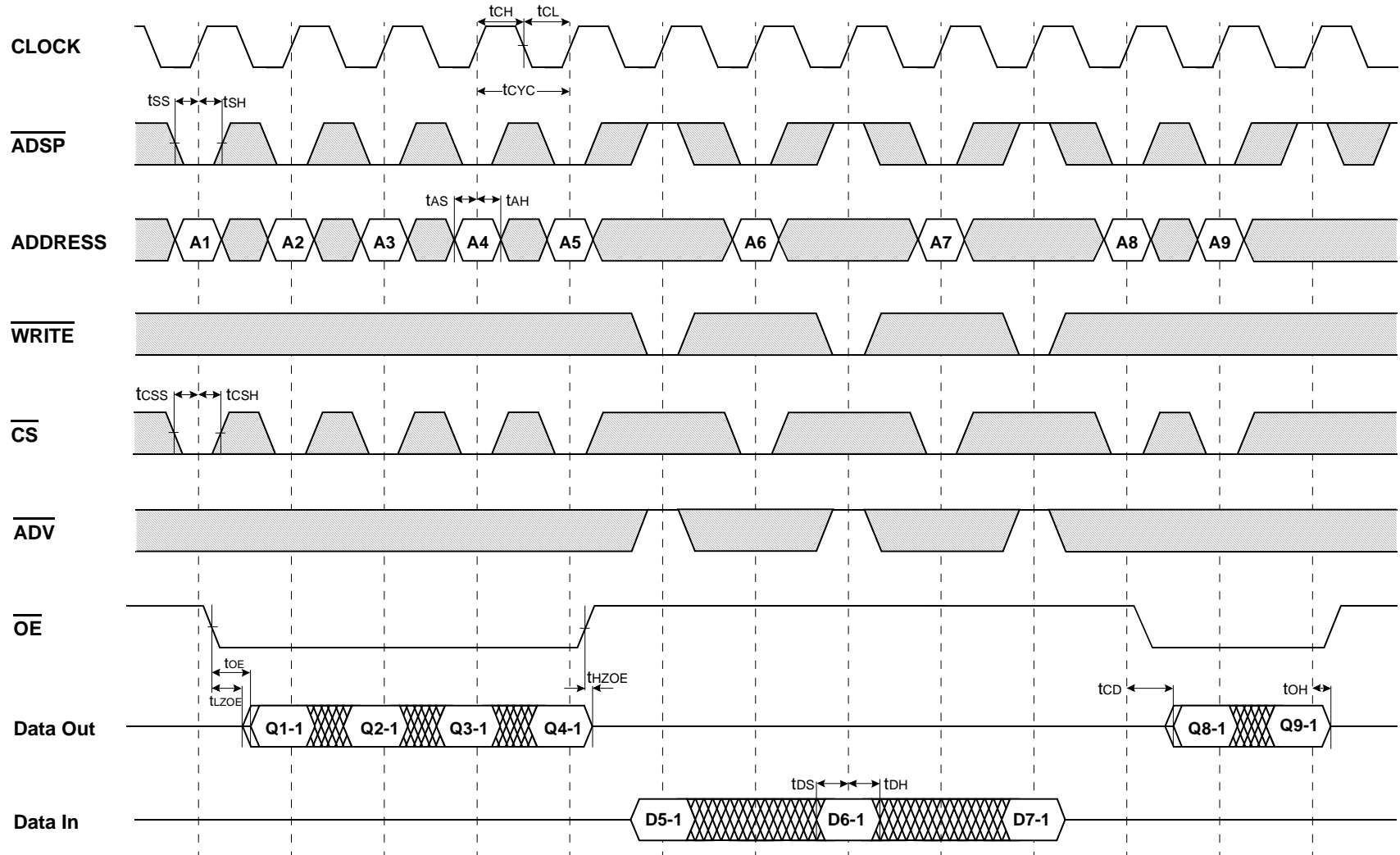

Don't Care
 Undefined

K7B403625B
K7B401825B

128Kx36 & 256Kx18 Synchronous SRAM

TIMING WAVEFORM OF POWER DOWN CYCLE

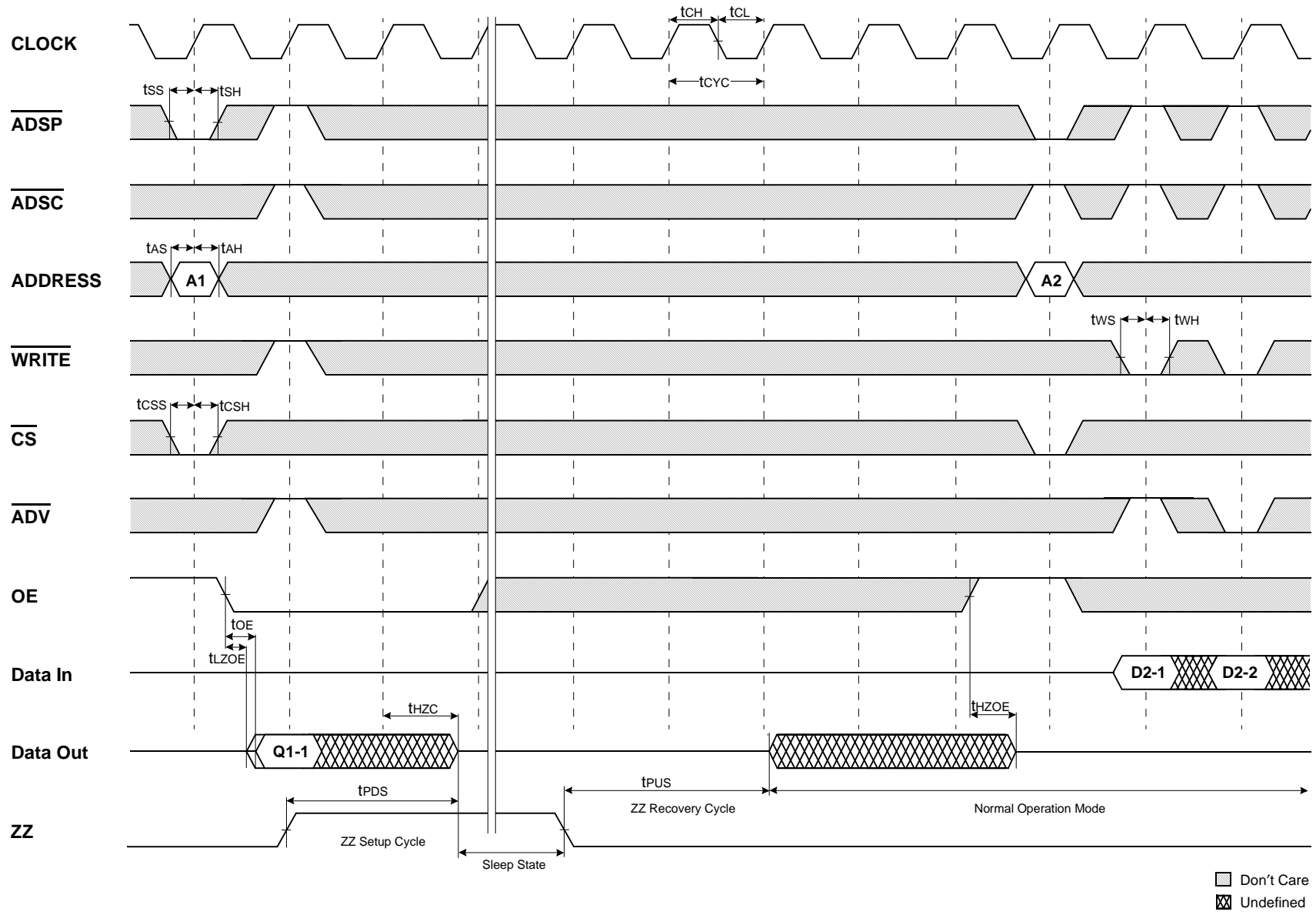

K7B403625B
K7B401825B

128Kx36 & 256Kx18 Synchronous SRAM

K7B403625B K7B401825B

128Kx36 & 256Kx18 Synchronous SRAM

APPLICATION INFORMATION

DEPTH EXPANSION

The Samsung 128Kx36 Synchronous Burst SRAM has two additional chip selects for simple depth expansion. This permits easy secondary cache upgrades from 128K depth to 256K depth without extra logic.

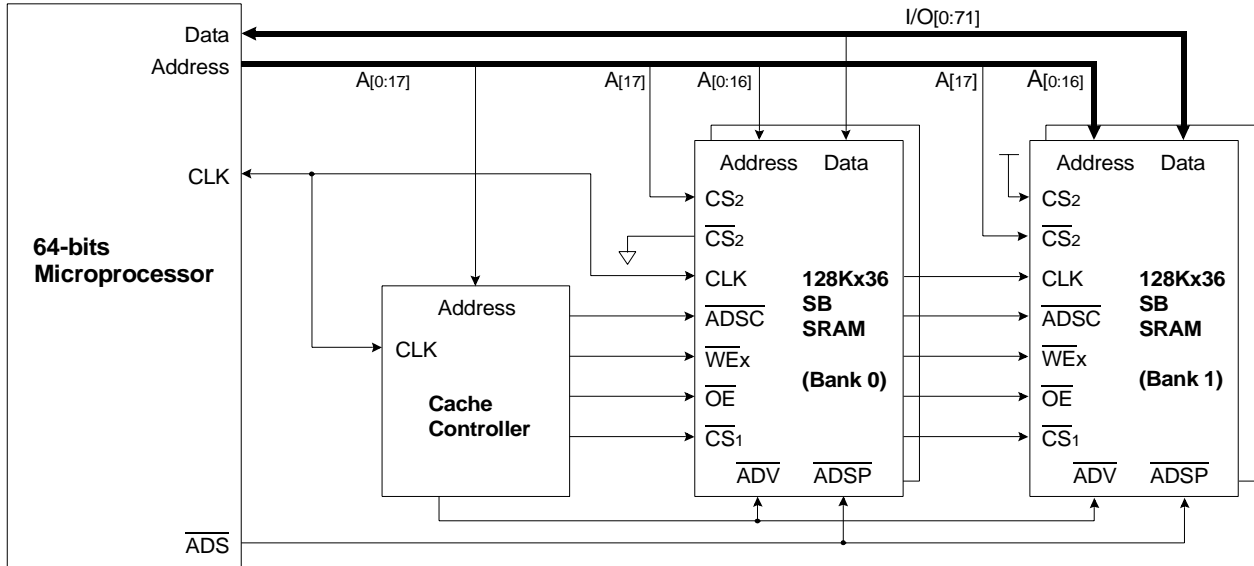

INTERLEAVE READ TIMING (Refer to non-interleave write timing for interleave write timing)

(\overline{ADSP} CONTROLLED, \overline{ADSC} =HIGH)

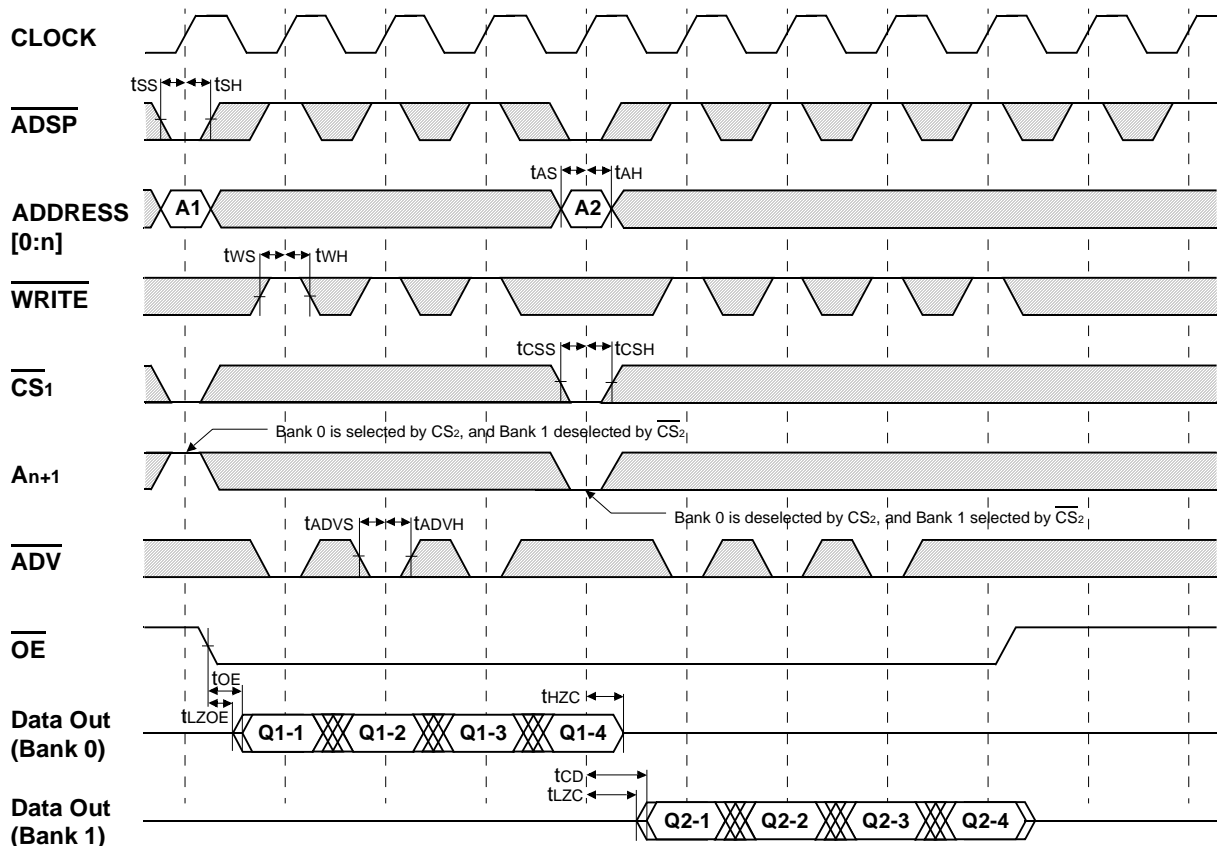

*Notes : n = 14 32K depth, 15 64K depth, 16 128K depth, 17 256K depth

□ Don't Care ⊗ Undefined

K7B403625B K7B401825B

128Kx36 & 256Kx18 Synchronous SRAM

APPLICATION INFORMATION

DEPTH EXPANSION

The Samsung 256Kx18 Synchronous Burst SRAM has two additional chip selects for simple depth expansion. This permits easy secondary cache upgrades from 256K depth to 512K depth without extra logic.

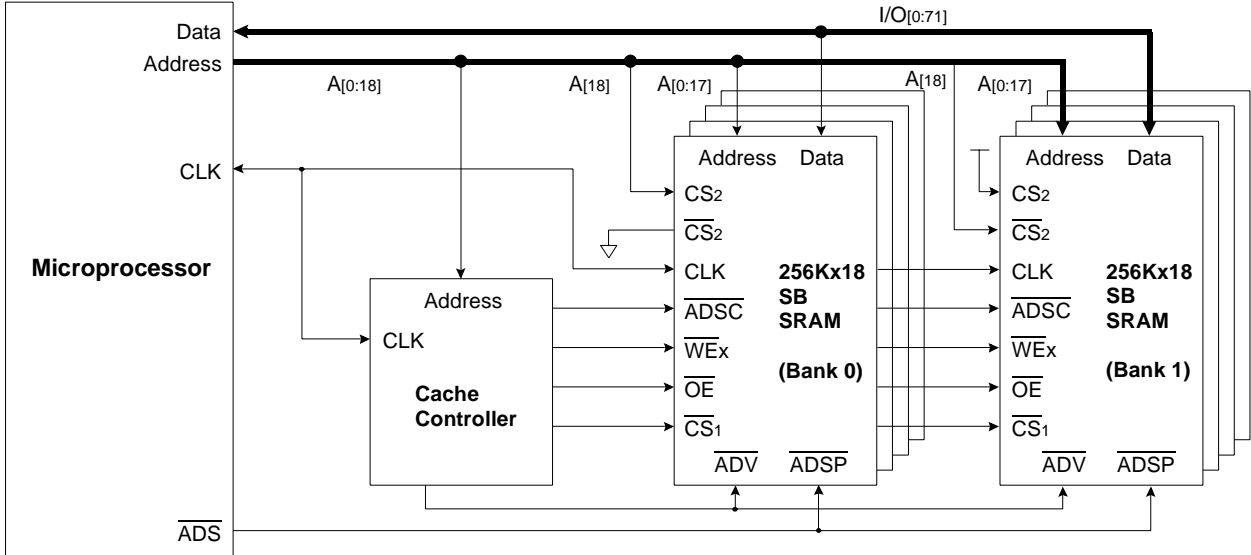

INTERLEAVE READ TIMING (Refer to non-interleave write timing for interleave write timing)

(ADSP CONTROLLED, ADSC=HIGH)

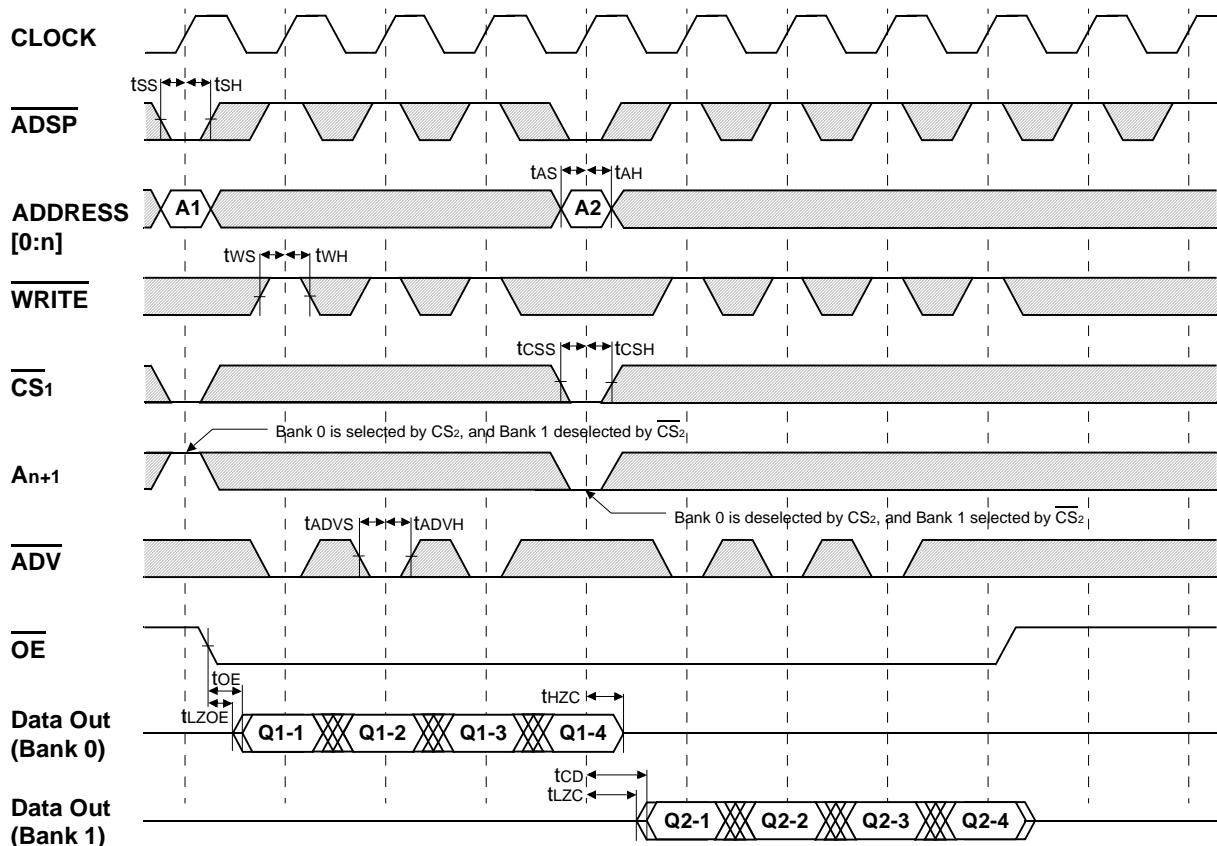

*Notes : n = 14 32K depth, 15 64K depth, 16 128K depth, 17 256K depth

□ Don't Care ⊗ Undefined

**K7B403625B
K7B401825B**

128Kx36 & 256Kx18 Synchronous SRAM

PACKAGE DIMENSIONS

100-TQFP-1420A (Lead & Lead-Free)

Units: millimeters/inches

