



LIS1R02 (L6671)

ANGULAR ACCELEROMETER

PRODUCT PREVIEW

- HIGH SENSITIVITY 2.5 rad/sec²
- 8 BIT A/D CONVERTER
- 800 Hz BANDWIDTH
- 200 rad/sec² FULL SCALE VALUE
- DIGITAL DOWNSAMPLING
- DIGITAL FILTERING
- 3.3V 3WIRES SERIAL INTERFACE (5V TOLLERANCE)
- EMBEDDED PLL

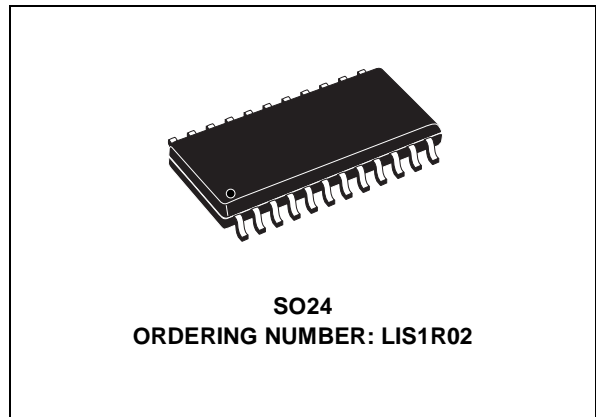

DESCRIPTION

The LIS1R02 is a complete rotational accelerometer system based on a $\Sigma\Delta$ architecture, followed by a digital downsampling block and a digital filter, featuring high sensitivity, 800 Hz signal bandwidth and a complete serial port interface for a direct connection

to microprocessor environment. An embedded PLL allows internal clock generation from an external synchronization signal.

BLOCK DIAGRAM

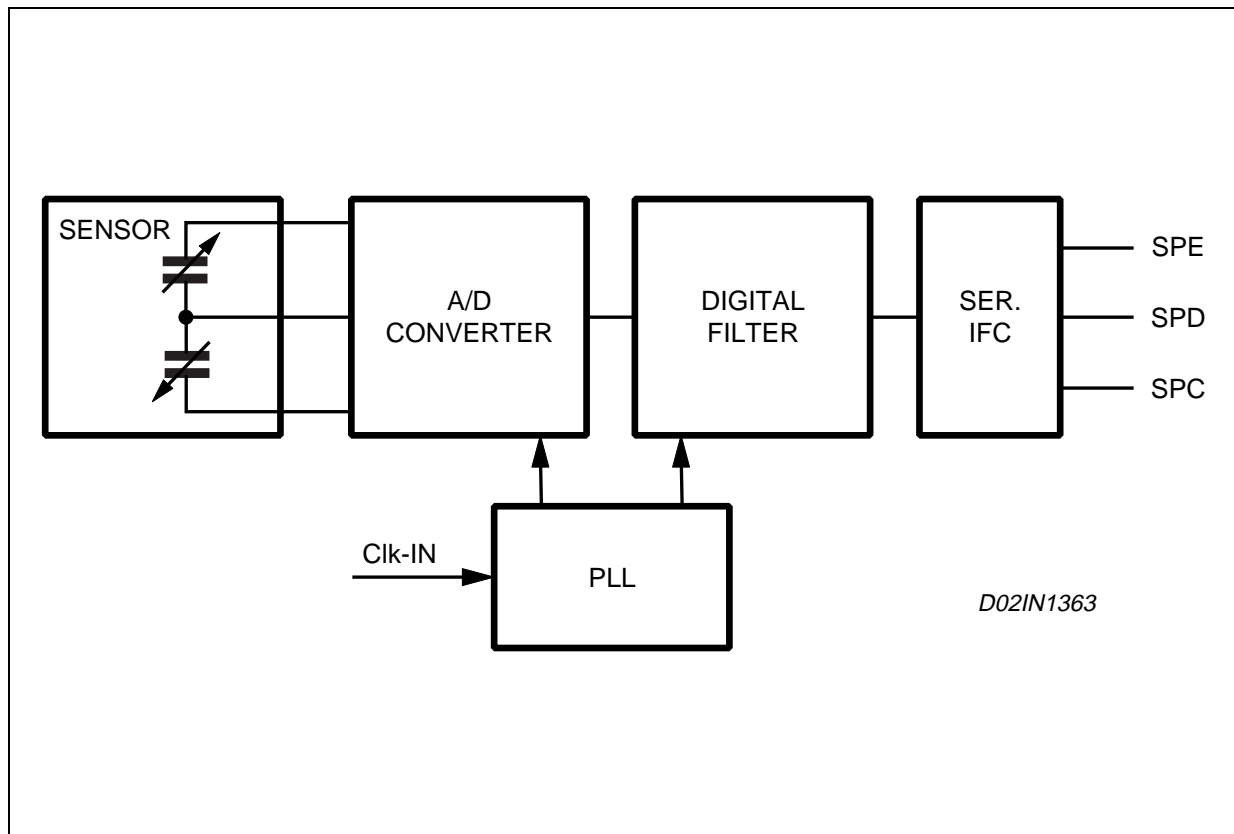

LIS1R02 (L6671)

PIN FUNCTION

N°. Pin	Name	Function Typ.	Condition
1 to 6	GND	Ground	
7	Vdd_Analog	Analog Voltage Supply	5V Typ. (*)
8	Ref_Cap	Reference Voltage Bypass	
9	HV_Eprom	EPROM Programming Voltage (test mode only)	Tied to GND
10	Vdd_Digital	Digital Voltage Supply	5V Typ. (**)
11	SPC	Serial Port Clock Signal	
12	SPD	Serial Port Data Signal	
19 to 24	GND	Ground	
13	SPE	Serial Port Enable Signal	
14	CLK_In	External Clock / PLL Reference Input	
15	Gnd_Digital	Digital Ground Pin	
16	Funct_Test	Self Test	
17	Test_ST	Test Pin	Tied to GND
18	Gnd_Analog	Analog Ground Pin	

(*) Must be shorted to Pin 10

(**) Must be shorted to Pin 7

PIN CONNECTIONS (Top view)

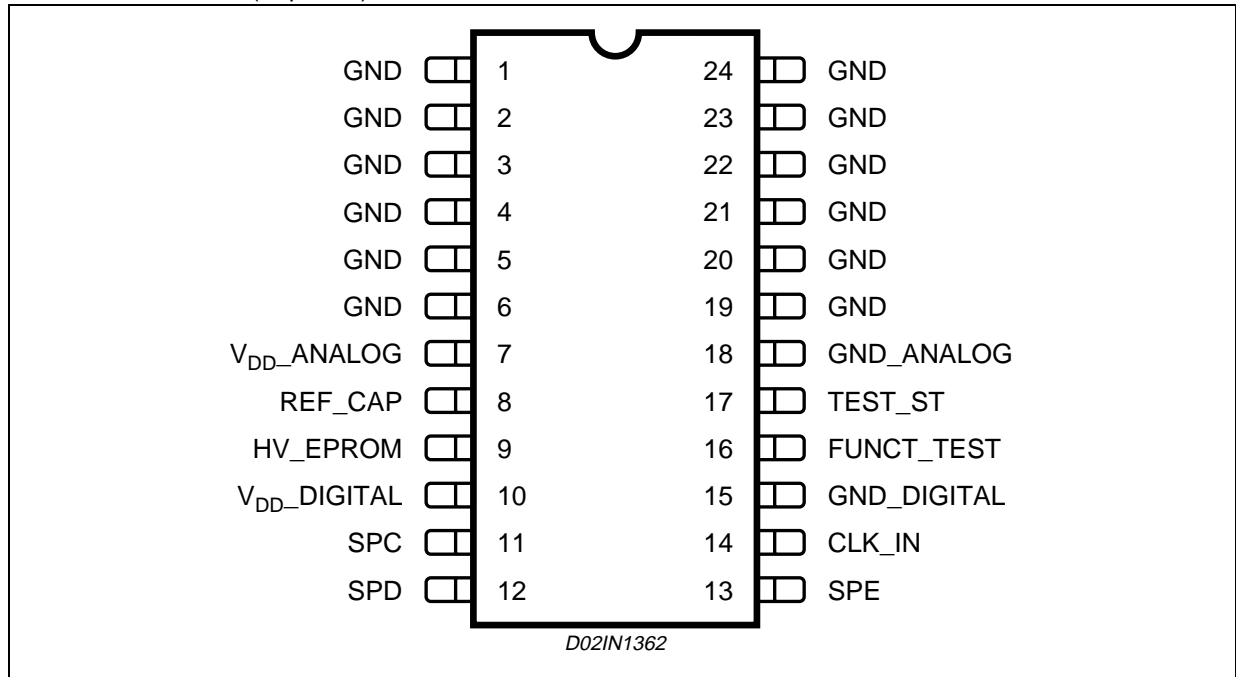

ABSOLUTE MAXIMUM RATINGS

Symbol	Parameter	Value	Unit
V _{ddAnalog Max}	Maximum analog supply voltage	7	V
V _{ddDigital Max}	Maximum digital supply voltage	7	V
V _{in}	Voltage Range on SPC, SPE, SPD, CLK_In, Funct_Test	-0.3 to V _{ddDig} + 0.3	

ELECTRICAL CHARACTERISTICS

Symbol	Parameter	Test Condition	Min.	Typ.	Max.	Unit
DC						
V _{ddAnalog Max}	Analog Supply Voltage		4.5	5.0	5.5	V
V _{ddDigital Max}	Digital Supply Voltage		4.5	5.0	5.5	V
I _{ddAnalog}	Analog Circuitry Supply Current			15		mA
I _{ddDigital}	Digital Circuitry Supply Current			11		mA
V _{ref}	Voltage on Ref_Cap pin			2.225		V
V _{oh}		(on SPD and Funct_Test) @ I _{oh} = 3mA		>2		V
V _{ol}				<1		V
V _{ih}				2.6		V
V _{il}				0.8		V
ADC						
	ADC SNR (30-800Hz, 4.48MHz Ext.Clk)		35	38		dB
	ADC SNR (30-10000Hz, 4.48MHz Ext.Clk)		15	20		dB
	Phase error	30-800Hz (relative to a ref. Accelerometer)		-30		deg
	ADC Full Scale			200		rad/ sec ²
	ADC Bandwidth			1-800		Hz
	ADC Dynamic Range			38		dB
	ADC Differential Linearity			<3%		
	ADC Integral Linearity			<5%		Full Scale
Mclk	Clock Frequency on CLK_In pin				6	MHz

LIS1R02 (L6671)

SERIAL PORT TIMINGS

Symbol	Parameter	Test Condition	Min.	Typ.	Max.	Unit
Pin SPC						
F _{pc}	SPC frequency	25pF maximum load	Mclk		30	MHz
Pin SPE						
T _{ec}	SPE to SPC		5		100	ns
T _{ce}	SPC to SPE		5		100	ns
T _{we}	SPE low		1 SPC Period			ns
Pin SPD (input)						
T _{ds}	SPD to SPC		5			ns
T _{dh}	SPC to SPD		2			ns
Pin SPD (output)						
T _{pd}	SPC to SPD			10		ns

Figure 1. Application Diagram

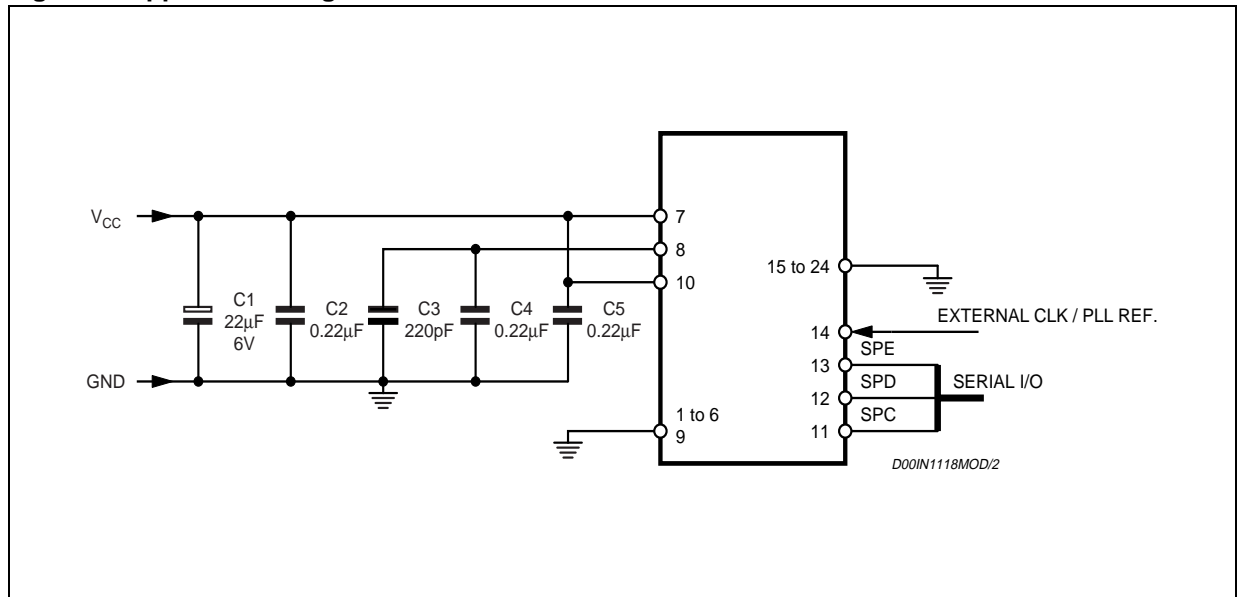

SERIAL PORT, REGISTERS, EPROM and TEST MODES

1.0 SERIAL PORT

1.1 READ & WRITE REGISTERS

Figure 2.

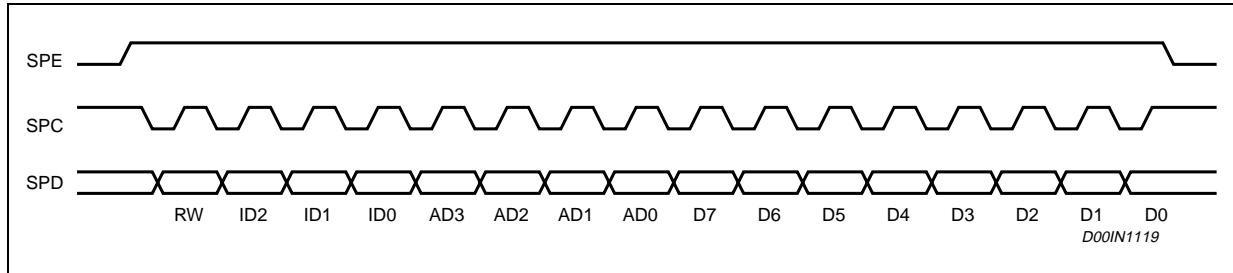

SPE is the Serial Port Enable. It goes high at the start of the transmission and goes back low at the end. SPC is the Serial Port Clock. It is stopped high when SPE is low (no transmission). SPD is the Serial Port Data. It is driven by the falling edge of SPC. It should be captured at the rising edge of SPC.

The Read Register or Write Register command consists of 16 clocks or bit. A bit duration is the time between two falling edges of SPC. The first bit (bit 0) starts at the first falling edge of SPC after the rising edge of SPE and the last bit (bit 15) starts at the last falling edge of SPC just before the falling edge of SPE.

- bit 0 : RW bit. When 0, the data (D7:0) is written into the device. When 1, the data (D7:0) from the device is read. In this case, the LIS1R02 will drive SPD at the start of bit 8.
- bit 1-3 : chip ID. The chip ID for the LIS1R02 is ID(2:0)=110. The device accepts the command only when the ID is valid (equal to 110).
- bit 4-7 : address AD(3:0). This is the address field for the registers. See section 2 for more details.
- bit 8-15 : data D(7:0). This is the data that will be written (read) into (from) the register whose address is AD(3:0).

1.2 READ FIFO

Figure 3.

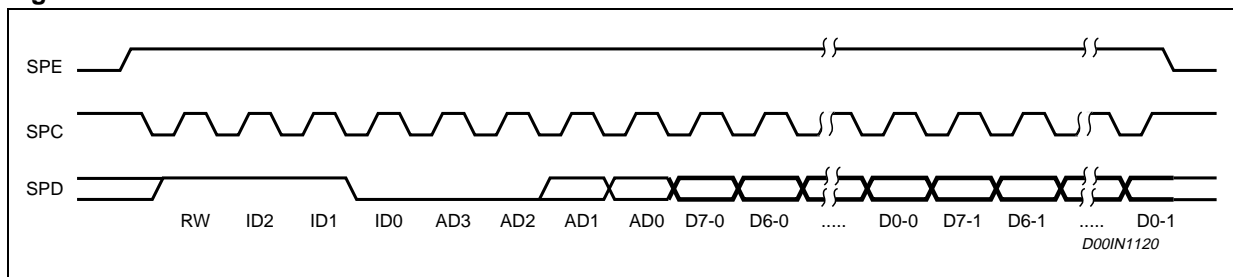

The Read FIFO command consists of 24 clocks or bits.

- bit 0 : READ bit. The value is 1.
- bit 1-3 : chip ID. ID(2:0)=110.
- bit 4-7 : FIFO address.
- bit 8-23: FIFO data.

LIS1R02 (L6671)

The FIFO has four registers grouped into two banks. The first bank consists of the first and the second register. The first register is the one written first since the last read. The second bank consists of the third and fourth register.

0000: address for the first bank

0010: address for the second bank

The device puts out first the data of the first register of the bank with the MSB first.

2.0 LIS1R02 REGISTERS

The registers are grouped into two banks. The following table summarizes their mapping.

Address	Reg. Bank 0	Reg. Bank 1
0000	FIFO_Low	FIFO_Low
0001	not used	not used
0010	FIFO_High	FIFO_High
0011	not used	not used
0100	CTRL_Reg1	CTRL_Reg1
0101	CTRL_Reg2	CTRL_Reg2
0110	PLL_PRESC_MULT	FLASH_Reg1
0111	PLL_MULT	FLASH_Reg2
1000	IIR_A0	GAIN_Low
1001	IIR_A1	GAIN_High
1010	IIR_A2	OFFSET_Low
1011	IIR_B1	OFFSET_High
1100	IIR_B2	CURR_BANDGAP
1101	IIR_SIGN_BIT	BAND_CSACT_Reg
1110	DSC_Reg	CS_TRIM
1111	MISC_Reg	MISC_Reg

2.1 Registers Bank 0

AD(3:0) = 0100 CTRL_Reg1

This is the first control register. It has 8 bit whose function is summarized below.

Note: x means don't care value.

Note: default value after Power On Reset is 0100 0000

1xxx xxxx Chip in Power Down mode

xx00 xxxx Clock from CLK pin

xx01 xxxx Clock derived from the internal oscillator

xx10 xxxx Clock from the PLL locking on CLK_in

xx11 xxxx Clock from the PLL locking on FIFO_Low reading

xxxx 1xxx Internal Oscillator in Power Down mode

xxxx x001 Bitstream in mode. The bitstream is sent in via pin Funct_Test while the bitstream clock is sent via CLK_pin. The output can be checked via the serial interface.

xxxx x010 Bistream out mode. The bitstream is sent out through pin SPD while the bitstream clock is sent through pin SPC. The pin TEST_ST must be tied to 1.5V.

xxxx x011 Internal clock check mode. The decimation signal is sent out through pin SPD while the main clock can be checked through pin SPC. The pin TEST_ST must be tied to 1.5V.

xxxx x100 Flash write mode

xxxx x101 Flash read mode

xxxx x11x Sensor trimming

AD(3:0) = 0101 CTRL_Reg2

This is the second control register. It has 8 bit whose function is summarized below.

Note: x means don't care value.

Note: default value after Power On Reset is 0110 0011

0xxx xxxx Delayed Synchronous Conversion reference coming from CLK_pin/FIFO_Low reading signal.

1xxx xxxx Low rate Delayed Synchronous Conversion reference signal.

x1xx xxxx Delayed Synchronous Conversion enabled.

xx1x xxxx Clip on. The result of the measuring chain is clipped when exceeding the maximum/minimum limit.

xxx0 0xxx 8 bit output word length

xxx0 1xxx 16 bit output word length

xxx1 xxxx 32 bit output word length

xxxx x1xx Bypass the embedded IIR filter

xxxx xx0x Set the decimation factor to 16. 32 when the bit is 1.

xxxx xxx0 Set the sinc order to 2. 3rd order when the bit is 1.

AD(3:0) = 0110 PLL_PRESC_MULT

This register contain the division factor used in the PLL prescaler and the most significant bit of the PLL multiplication factor.

AD(3:0) = 0111 PLL_PRESC_MULT

This register contain the least significant bit of the PLL multiplication factor.

AD(3:0) = 1000 IIR_A0

This register contain the A0 coefficient used in the embedded IIR register.

AD(3:0) = 1001 IIR_A1

This register contain the A1 coefficient used in the embedded IIR register.

AD(3:0) = 1010 IIR_A2

This register contain the A2 coefficient used in the embedded IIR register.

AD(3:0) = 1011 IIR_B1

This register contain the B1 coefficient used in the embedded IIR register.

LIS1R02 (L6671)

AD(3:0) = 1100 IIR_B2

This register contain the B2 coefficient used in the embedded IIR register.

AD(3:0) = 1101 IIR_SIGN_BIT

This register contain the sign bit of the coefficients used in the embedded IIR register.

AD(3:0) = 1110 DSC_Reg

This register contain the threshold value used to trigger the decimation when the Delayed Synchronous Conversion mode is enabled.

AD(3:0) = 1111 MISC_Reg

This is the miscellaneous register.

Note: default value after Power On Reset is 0010 0000

1xxx 0x0x Force a SW reset.

x1xx xx0x Enters PLL test mode.

Bit 2-5 Define the internal oscillator division factor.

xxxx xx01 Switch to Registers Bank 1.

2.2 Registers Bank 1

AD(3:0) = 0100 CTRL_Reg1

This is the second control register.

AD(3:0) = 0101 CTRL_Reg2

This is the second control register.

AD(3:0) = 0110 FLASH_REG1

This register is used to program the embedded memory.

AD(3:0) = 0111 FLASH_REG1

This register is used to program the embedded memory.

AD(3:0) = 1000 GAIN_Low

These are the 8 LSB of gain for the adjustment unit.

AD(3:0) = 1001 GAIN_High

These are the 8 MSB of gain for the adjustment unit.

AD(3:0) = 1010 OFFSET_Low

These are the 8 LSB of offset for the adjustment unit.

AD(3:0) = 1011 OFFSET_High

These are the 8 MSB of offset for the adjustment unit.

AD(3:0) = 1100 CURR_BANDGAP

This register is used for references trimming.

AD(3:0) = 1101 BAND_CSACT_Reg

This register is used for interface trimming and sensor actuation.

AD(3:0) = 1110 CSTRIM_Reg

This register is used for sensor trimming.

AD(3:0) = 1111 MISC_Reg

This is the miscellaneous register.

3.0 LIS1R02 COMPATIBILITY VERSUS L6670

Externally LIS1R02 presents the same pin-out of L6670.

To have full compatibility with L6670 in terms of bitstream processing it is necessary to write the following configuration inside the LIS1R02 registers:

CTRL_REG1: 0100 0000

CTRL_REG2: 0010 0111

LIS1R02 (L6671)

DIM.	mm			inch		
	MIN.	TYP.	MAX.	MIN.	TYP.	MAX.
A	2.35		2.65	0.093		0.104
A1	0.10		0.30	0.004		0.012
A2			2.55			0.100
B	0.33		0.51	0.013		0.0200
C	0.23		0.32	0.009		0.013
D	15.20		15.60	0.598		0.614
E	7.40		7.60	0.291		0.299
e		1.27			0,050	
H	10.0		10.65	0.394		0.419
h	0.25		0.75	0.010		0.030
k	0° (min.), 8° (max.)					
L	0.40		1.27	0.016		0.050

OUTLINE AND MECHANICAL DATA

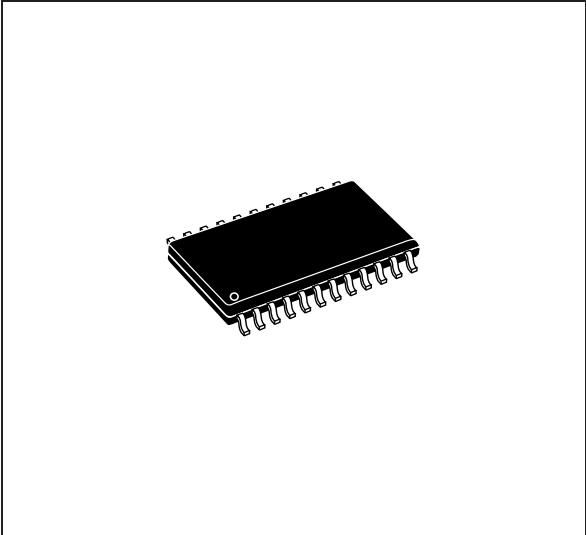

SO24

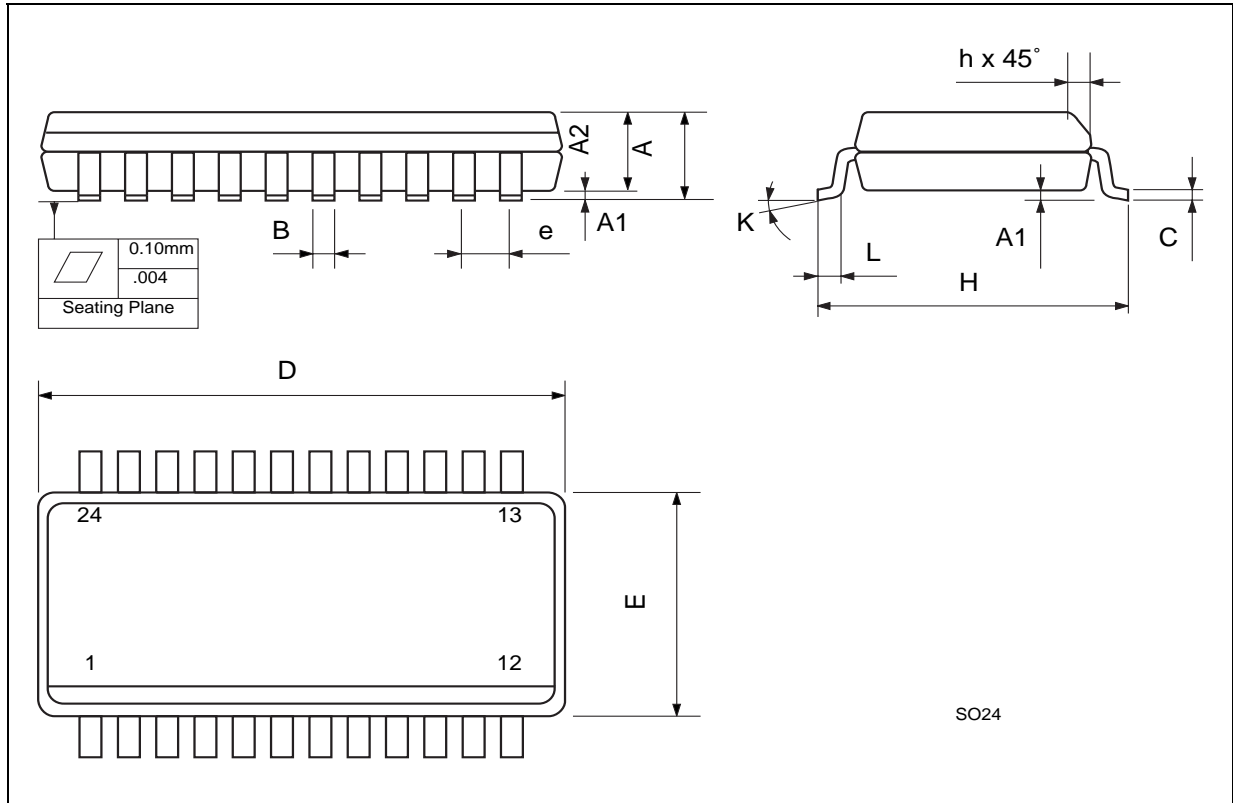

Information furnished is believed to be accurate and reliable. However, STMicroelectronics assumes no responsibility for the consequences of use of such information nor for any infringement of patents or other rights of third parties which may result from its use. No license is granted by implication or otherwise under any patent or patent rights of STMicroelectronics. Specifications mentioned in this publication are subject to change without notice. This publication supersedes and replaces all information previously supplied. STMicroelectronics products are not authorized for use as critical components in life support devices or systems without express written approval of STMicroelectronics.

The ST logo is a registered trademark of STMicroelectronics
© 2002 STMicroelectronics - All Rights Reserved

STMicroelectronics GROUP OF COMPANIES
Australia - Brazil - Canada - China - Finland - France - Germany - Hong Kong - India - Israel - Italy - Japan -Malaysia - Malta - Morocco -
Singapore - Spain - Sweden - Switzerland - United Kingdom - United States.
<http://www.st.com>