



ISO HIGH SIDE SMART POWER SOLID STATE RELAY

TYPE	V _{DSS}	R _{DS(on)}	I _{OUT}	V _{CC}
VND05BSP	40 V	0.2 Ω	1.6 A	26 V

- OUTPUT CURRENT (CONTINUOUS):
9A @ T_c = 85°C PER CHANNEL
- 5V LOGIC LEVEL COMPATIBLE INPUT
- THERMAL SHUT-DOWN
- UNDER VOLTAGE PROTECTION
- OPEN DRAIN DIAGNOSTIC OUTPUT
- INDUCTIVE LOAD FAST
DEMAGNETIZATION
- VERY LOW STAND-BY POWER
DISSIPATION

DESCRIPTION

The VND05BSP is a monolithic device made using STMicroelectronics VIPower Technology, intended for driving resistive or inductive loads with one side grounded. This device has two channels, and a common diagnostic. Built-in thermal shut-down protects the chip from over temperature and short circuit.

The status output provides an indication of open load in on state, open load in off state, overtemperature conditions and stuck-on to V_{CC}.

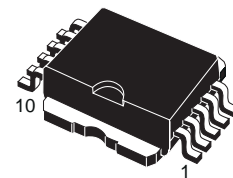

PowerSO-10

BLOCK DIAGRAM

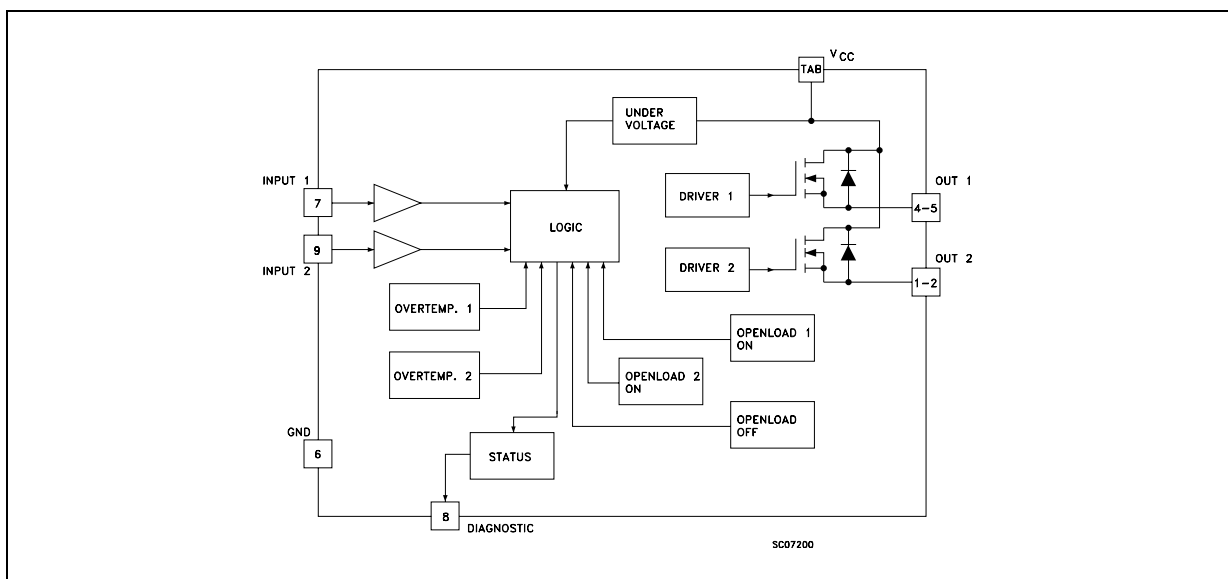

VND05BSP

ABSOLUTE MAXIMUM RATING

Symbol	Parameter	Value	Unit
$V_{(BR)DSS}$	Drain-Source Breakdown Voltage	40	V
I_{OUT}	Output Current (cont.) at $T_c = 85\text{ }^\circ\text{C}$	9	A
$I_{OUT(RMS)}$	RMS Output Current at $T_c = 85\text{ }^\circ\text{C}$ and $f > 1\text{ Hz}$	9	A
I_R	Reverse Output Current at $T_c = 85\text{ }^\circ\text{C}$	-9	A
I_{IN}	Input Current	± 10	mA
$-V_{CC}$	Reverse Supply Voltage	-4	V
I_{STAT}	Status Current	± 10	mA
V_{ESD}	Electrostatic Discharge (1.5 k Ω , 100 pF)	2000	V
P_{tot}	Power Dissipation at $T_c = 25\text{ }^\circ\text{C}$	59	W
T_j	Junction Operating Temperature	-40 to 150	$^\circ\text{C}$
T_{stg}	Storage Temperature	-55 to 150	$^\circ\text{C}$

CONNECTION DIAGRAMS

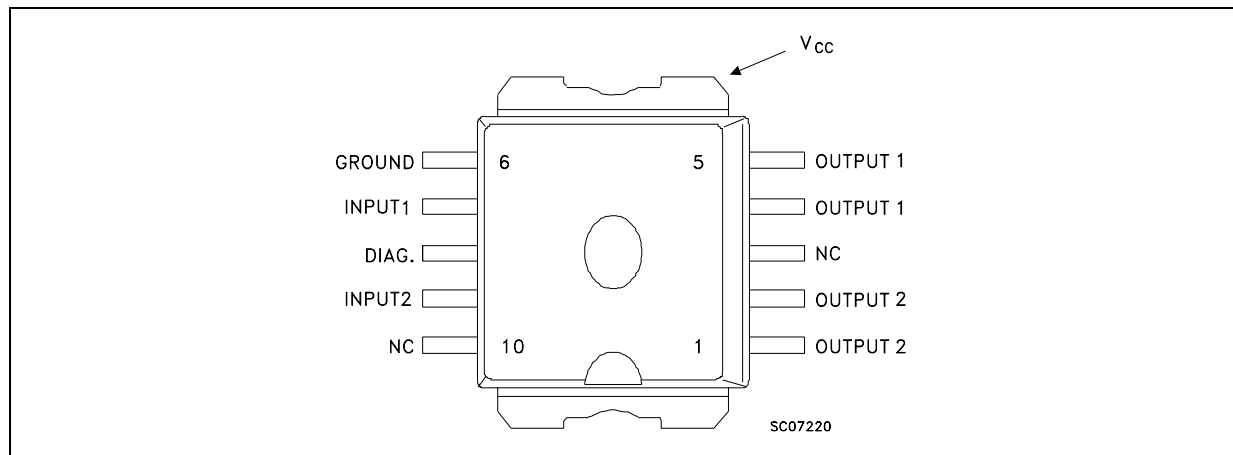

CURRENT AND VOLTAGE CONVENTIONS

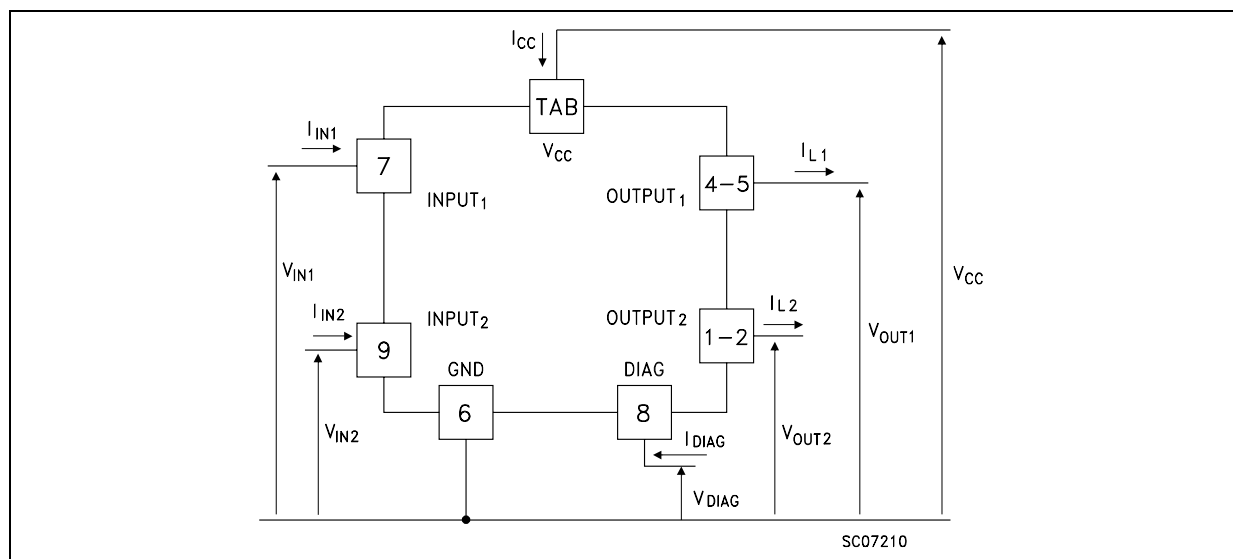

THERMAL DATA

$R_{thj-case}$	Thermal Resistance Junction-case	Max	2.1	$^{\circ}\text{C}/\text{W}$
$R_{thj-amb}$	Thermal Resistance Junction-ambient (\$)	Max	50	$^{\circ}\text{C}/\text{W}$

(\$) When mounted using minimum recommended pad size on FR-4 board

ELECTRICAL CHARACTERISTICS ($8 < V_{CC} < 16 \text{ V}$; $-40 \leq T_j \leq 125 \text{ }^{\circ}\text{C}$ unless otherwise specified)

POWER

Symbol	Parameter	Test Conditions	Min.	Typ.	Max.	Unit
V_{CC}	Supply Voltage		6	13	26	V
I_n (*)	Nominal Current	$T_c = 85 \text{ }^{\circ}\text{C}$ $V_{DS(on)} \leq 0.5$ $V_{CC} = 13 \text{ V}$	1.6		2.6	A
R_{on}	On State Resistance	$I_{OUT} = I_n$ $V_{CC} = 13 \text{ V}$ $T_j = 25 \text{ }^{\circ}\text{C}$	0.13		0.2	Ω
I_s	Supply Current	Off State $T_j = 25 \text{ }^{\circ}\text{C}$ $V_{CC} = 13 \text{ V}$		35	100	μA
$V_{DS(MAX)}$	Maximum Voltage Drop	$I_{OUT} = 7.5 \text{ A}$ $T_j = 85 \text{ }^{\circ}\text{C}$ $V_{CC} = 13 \text{ V}$	1.44		2.3	V
R_i	Output to GND internal Impedance	$T_j = 25 \text{ }^{\circ}\text{C}$	5	10	20	$\text{K}\Omega$

SWITCHING

Symbol	Parameter	Test Conditions	Min.	Typ.	Max.	Unit
$t_{d(on)}(\wedge)$	Turn-on Delay Time Of Output Current	$R_{out} = 5.4 \text{ } \Omega$	5	25	200	μs
$t_r(\wedge)$	Rise Time Of Output Current	$R_{out} = 5.4 \text{ } \Omega$	10	50	180	μs
$t_{d(off)}(\wedge)$	Turn-off Delay Time Of Output Current	$R_{out} = 5.4 \text{ } \Omega$	10	75	250	μs
$t_f(\wedge)$	Fall Time Of Output Current	$R_{out} = 5.4 \text{ } \Omega$	10	35	180	μs
$(di/dt)_{on}$	Turn-on Current Slope	$R_{out} = 5.4 \text{ } \Omega$	0.003		0.1	$\text{A}/\mu\text{s}$
$(di/dt)_{off}$	Turn-off Current Slope	$R_{out} = 5.4 \text{ } \Omega$	0.005		0.1	$\text{A}/\mu\text{s}$

LOGIC INPUT

Symbol	Parameter	Test Conditions	Min.	Typ.	Max.	Unit
V_{IL}	Input Low Level Voltage				1.5	V
V_{IH}	Input High Level Voltage		3.5		(*)	V
$V_{I(hyst.)}$	Input Hysteresis Voltage		0.2	0.9	1.5	V
I_{IN}	Input Current	$V_{IN} = 5 \text{ V}$ $T_j = 25 \text{ }^{\circ}\text{C}$		30	100	μA
V_{ICL}	Input Clamp Voltage	$I_{IN} = 10 \text{ mA}$ $I_{IN} = -10 \text{ mA}$	5	6 -0.7	7	V V

ELECTRICAL CHARACTERISTICS (continued)
PROTECTION AND DIAGNOSTICS

Symbol	Parameter	Test Conditions	Min.	Typ.	Max.	Unit
V _{STAT}	Status Voltage Output Low	I _{STAT} = 1.6 mA			0.4	V
V _{USD}	Under Voltage Shut Down		3.5	4.5	6	V
V _{SCL}	Status Clamp Voltage	I _{STAT} = 10 mA I _{STAT} = -10 mA	5	6 -0.7	7	V V
T _{TSD}	Thermal Shut-down Temperature		140	160	180	°C
T _{SD(hyst.)}	Thermal Shut-down Hysteresis				50	°C
T _R	Reset Temperature		125			°C
V _{OL}	Open Voltage Level	Off-State (note 2)	2.5	4	5	V
I _{OL}	Open Load Current Level	On-State	5		180	mA
t _{povl}	Status Delay	(note 3)		5	10	µs
t _{pol}	Status Delay	(note 3)	50	500	2500	µs

(*) I_n= Nominal current according to ISO definition for high side automotive switch (see note 1)

NOTE = (∧) See switching time waveform

NOTE = (●) The V_{IH} is internally clamped at 6V about. It is possible to connect this pin to an higher voltage via an external resistor calculated to not exceed 10 mA at the input pin.

NOTE = note 1: The Nominal Current is the current at T_c = 85 °C for battery voltage of 13V which produces a voltage drop of 0.5 V

NOTE = note 2: I_{OL(off)} = (V_{CC} -V_{OL})/R_{OL}

note 3:t_{povl} t_{pol}: ISO definition.

Note 2 Relevant Figure

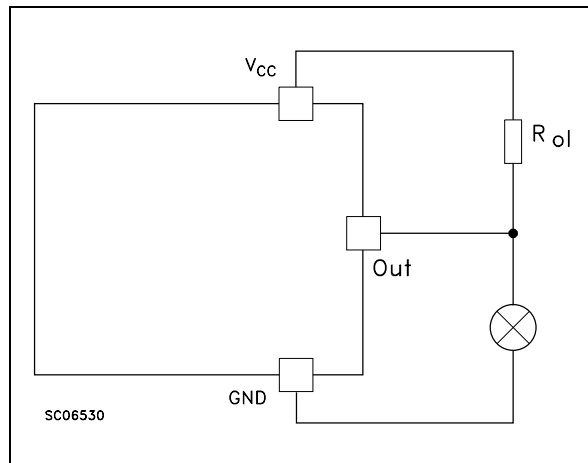

Note 3 Relevant Figure

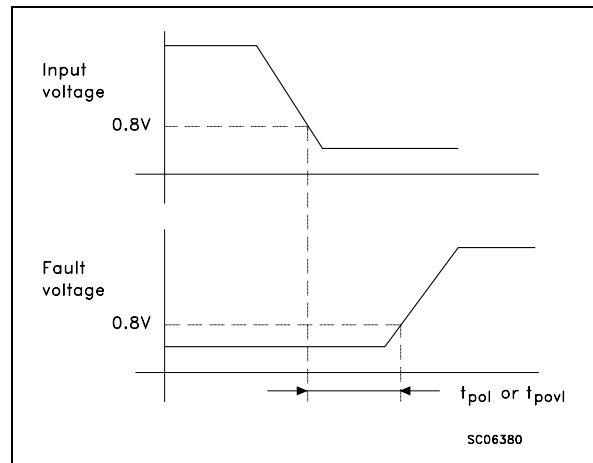

Switching Time Waveforms

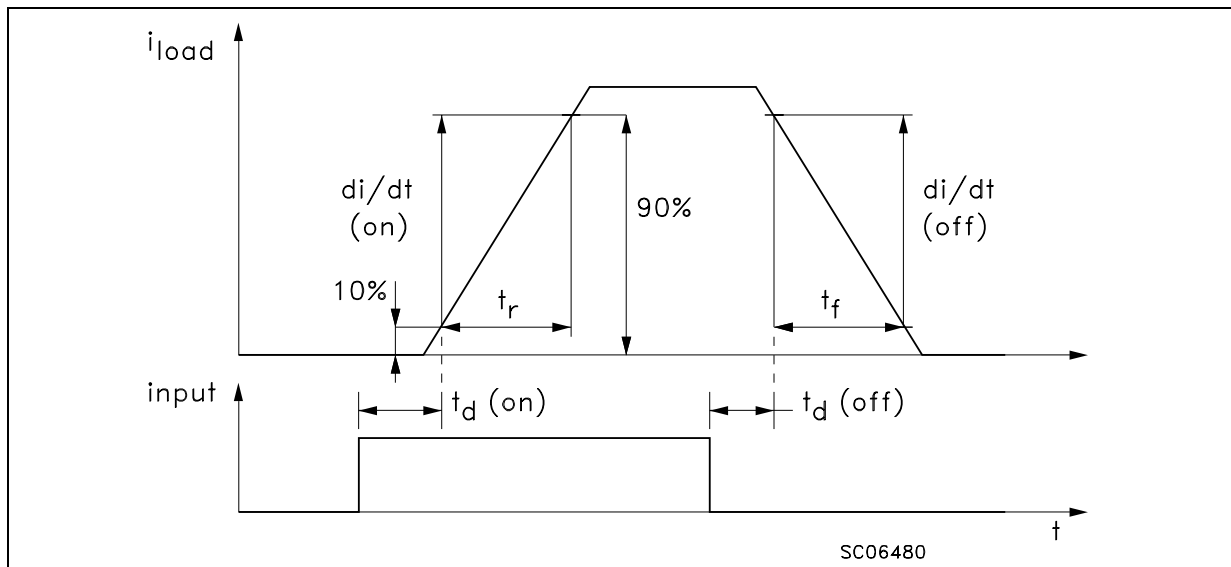
**FUNCTIONAL DESCRIPTION**

The device has a diagnostic output which indicates open load in on-state, open load in off-state, over temperature conditions and stuck-on to V_{CC} .

From the falling edge of the input signal, the status output, initially low to signal a fault condition (overtemperature or open load on-state), will go back to a high state with a different delay in case of overtemperature (t_{povl}) and in case of open load (t_{pol}) respectively. This feature allows to discriminate the nature of the detected fault. To protect the device against short circuit and over current condition, the thermal protection turns the integrated Power MOS off at a minimum junction temperature of $140\text{ }^{\circ}\text{C}$. When this temperature returns to $125\text{ }^{\circ}\text{C}$ the switch is automatically turned on again. In short circuit the protection reacts with virtually no delay, the sensor being located inside the Power MOS area. An internal function of the devices ensures the fast demagnetization of inductive loads with a typical voltage (V_{demag}) of -18V . This function allows to greatly reduce the power dissipation according to the formula:

$$P_{dem} = 0.5 \cdot L_{load} \cdot (I_{load})^2 \cdot [(V_{CC} + V_{demag}) / V_{demag}] \cdot f$$

where f = switching frequency and V_{demag} = demagnetization voltage.

The maximum inductance which causes the chip

temperature to reach the shut-down temperature in a specified thermal environment is a function of the load current for a fixed V_{CC} , V_{demag} and f according to the above formula. In this device if the GND pin is disconnected, with V_{CC} not exceeding 16V , it will switch off.

PROTECTING THE DEVICE AGAINST REVERSE BATTERY

The simplest way to protect the device against a continuous reverse battery voltage (-26V) is to insert a Schottky diode between pin 1 (GND) and ground, as shown in the typical application circuit (fig.3).

The consequences of the voltage drop across this diode are as follows:

If the input is pulled to power GND, a negative voltage of $-V_f$ is seen by the device. (V_{il} , V_{ih} thresholds and V_{stat} are increased by V_f with respect to power GND).

The undervoltage shutdown level is increased by V_f .

If there is no need for the control unit to handle external analog signals referred to the power GND, the best approach is to connect the reference potential of the control unit to node [1] (see application circuit in fig. 3), which becomes the common signal GND for the whole control board avoiding shift of V_{ih} , V_{il} and V_{stat} . This solution allows the use of a standard diode.

TRUTH TABLE

		INPUT 1	INPUT 2	OUTPUT 1	OUTPUT 2	DIAGNOSTIC
Normal Operation		L	L	L	L	H
		H	H	H	H	H
		L	H	L	H	H
		H	L	H	L	H
Under-voltage		X	X	L	L	H
Thermal Shutdown	Channel 1	H	X	L	X	L
	Channel 2	X	H	X	L	L
Open Load	Channel 1	H	X	H	X	L
		L	L	L	L	L(**)
	Channel 2	X	H	X	H	L
		L	L	L	L	L(**)
Output Shorted to V _{CC}	Channel 1	H	X	H	X	L
		L	L	H	L	L
	Channel 2	X	H	X	H	L
		L	L	L	H	L

(**) with additional external resistor.

Figure 1: Waveforms

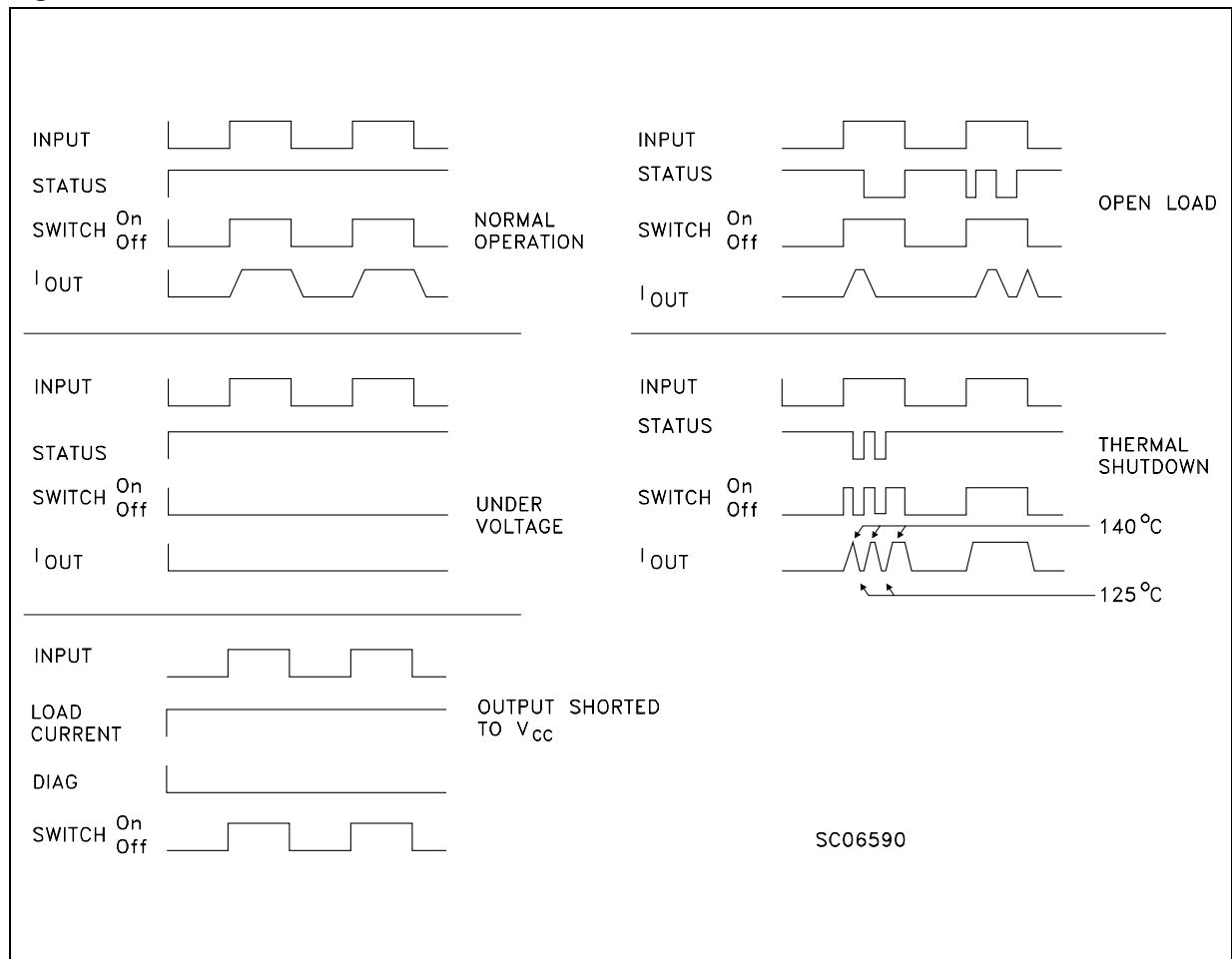

Figure 2: Typical Application Circuit With A Schottky Diode For Reverse Supply Protection

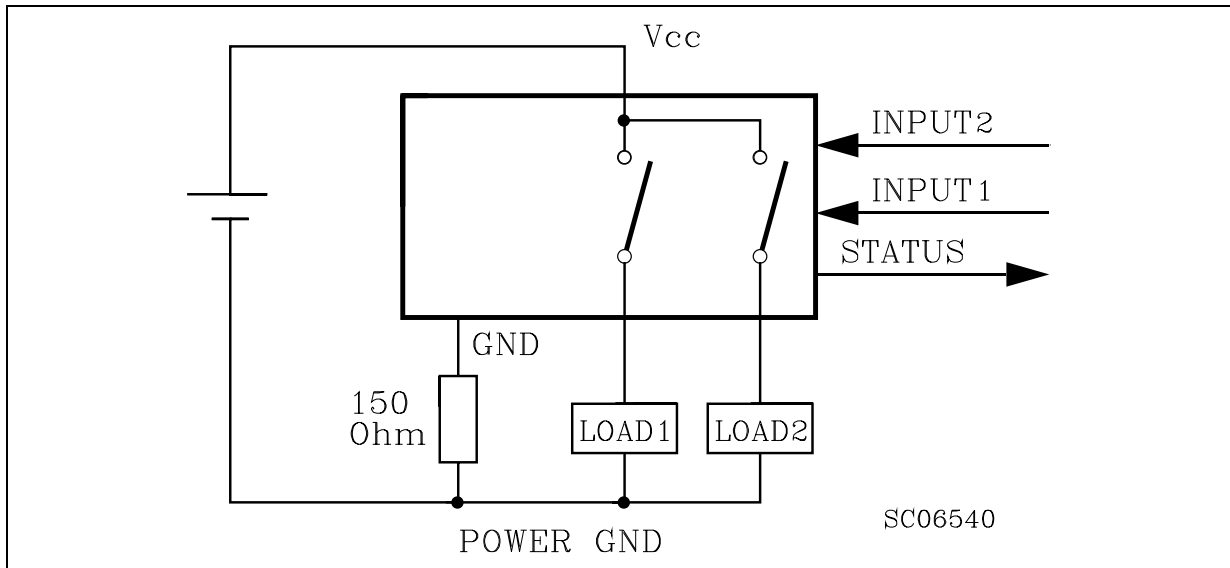
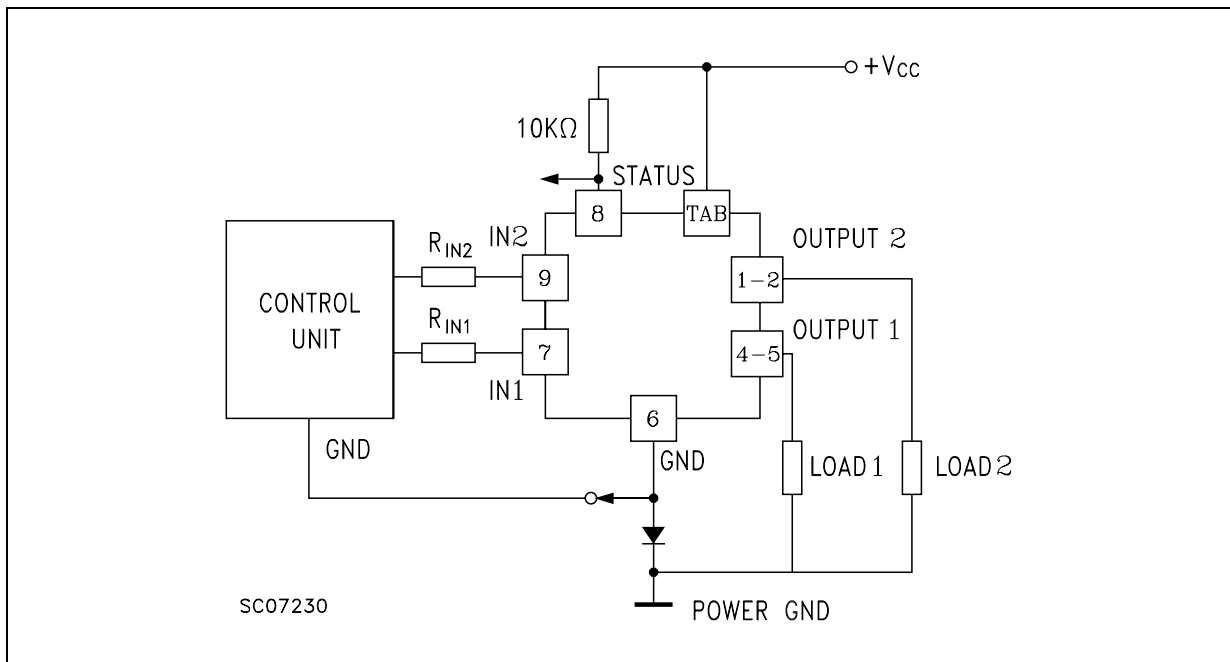

Figure 3: Typical Application Circuit With Separate Signal Ground



PowerSO-10™ MECHANICAL DATA

DIM.	mm.			inch		
	MIN.	TYP	MAX.	MIN.	TYP.	MAX.
A	3.35		3.65	0.132		0.144
A (*)	3.4		3.6	0.134		0.142
A1	0.00		0.10	0.000		0.004
B	0.40		0.60	0.016		0.024
B (*)	0.37		0.53	0.014		0.021
C	0.35		0.55	0.013		0.022
C (*)	0.23		0.32	0.009		0.0126
D	9.40		9.60	0.370		0.378
D1	7.40		7.60	0.291		0.300
E	9.30		9.50	0.366		0.374
E2	7.20		7.60	0.283		300
E2 (*)	7.30		7.50	0.287		0.295
E4	5.90		6.10	0.232		0.240
E4 (*)	5.90		6.30	0.232		0.248
e		1.27			0.050	
F	1.25		1.35	0.049		0.053
F (*)	1.20		1.40	0.047		0.055
H	13.80		14.40	0.543		0.567
H (*)	13.85		14.35	0.545		0.565
h		0.50			0.002	
L	1.20		1.80	0.047		0.070
L (*)	0.80		1.10	0.031		0.043
α	0°		8°	0°		8°
α (*)	2°		8°	2°		8°

(*) Muar only POA P013P

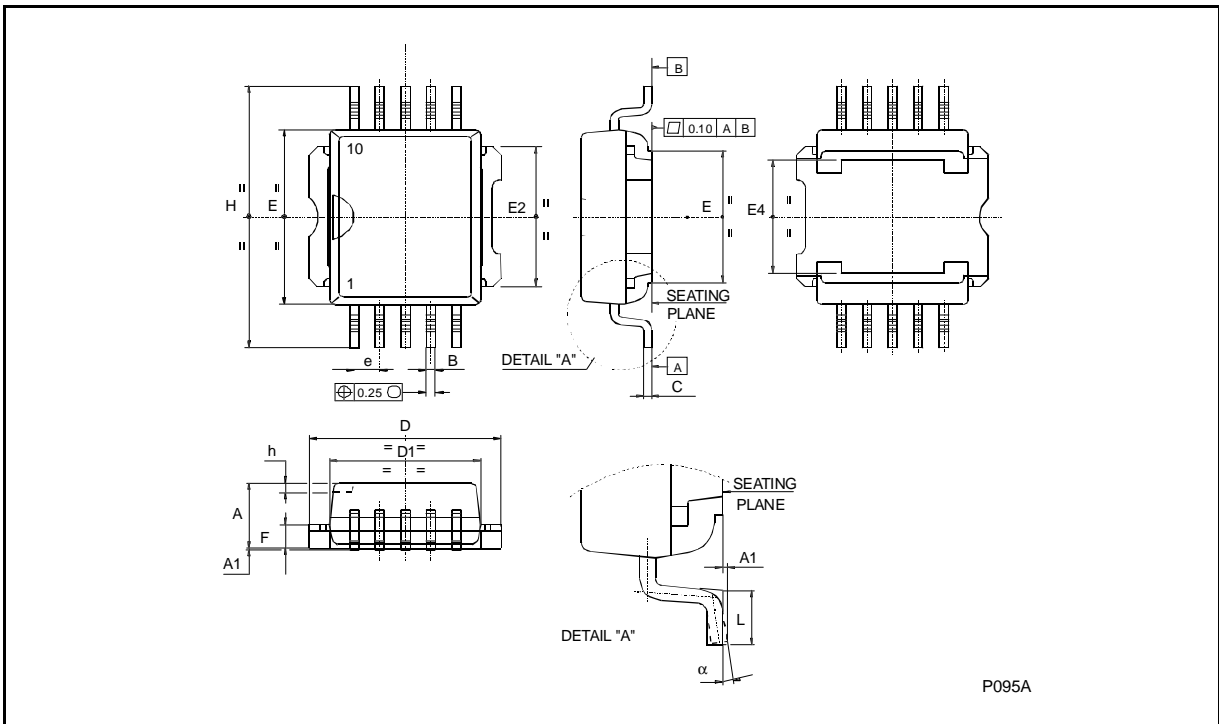

Information furnished is believed to be accurate and reliable. However, STMicroelectronics assumes no responsibility for the consequences of use of such information nor for any infringement of patents or other rights of third parties which may result from its use. No license is granted by implication or otherwise under any patent or patent rights of STMicroelectronics. Specification mentioned in this publication are subject to change without notice. This publication supersedes and replaces all information previously supplied. STMicroelectronics products are not authorized for use as critical components in life support devices or systems without express written approval of STMicroelectronics.

The ST logo is a trademark of STMicroelectronics

© 2000 STMicroelectronics – Printed in Italy – All Rights Reserved

STMicroelectronics GROUP OF COMPANIES

Australia - Brazil - China - Finland - France - Germany - Hong Kong - India - Italy - Japan - Malaysia - Malta - Morocco -
Singapore - Spain - Sweden - Switzerland - United Kingdom - U.S.A.

<http://www.st.com>