

50mm (2.0") 5x7 DOT MATRIX DISPLAY



SUN LED

Email : sales@us.sunled.com

Web Site : www.sunled.com

XMMR50A

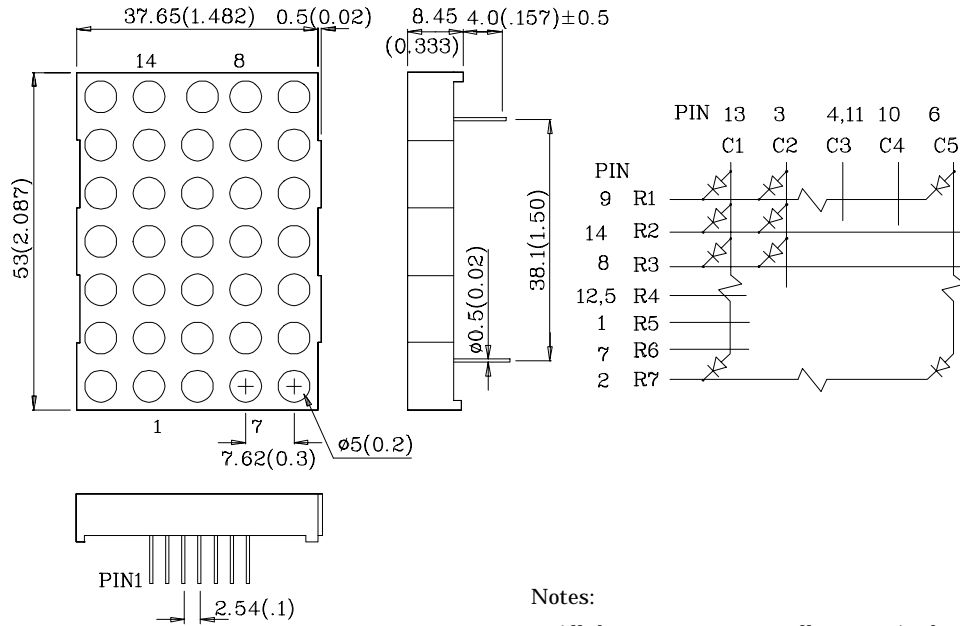

Notes:

1. All dimensions are in millimeters (inches).
2. Tolerance is $\pm 0.25(0.01)$ unless otherwise noted.

Absolute maximum ratings ($T_A=25^\circ\text{C}$)		MR (GaAlAs)	Unit
Reverse voltage	V_R	5	V
Forward current	I_F	30	mA
Forward current (peak) 1/10Duty cycle 0.1ms pulse width	i_{FS}	155	mA
Power dissipation	P_T	100	mW
Operating temperature	T_A	-40 ~ +85	$^\circ\text{C}$
Storage temperature	T_{stg}		
Lead solder temperature [2mm below package base]	260 $^\circ\text{C}$ For 5 Seconds		

Operating Characteristics ($T_A=25^\circ\text{C}$)		MR (GaAlAs)	Unit
Forward voltage (typ.) ($I_F=10\text{mA}$)	V_F	1.8	V
Forward voltage (max.) ($I_F=10\text{mA}$)	V_F	2.5	V
Reverse current ($V_R=5\text{V}$)	I_R	10	μA
Wavelength at peak emission ($I_F=10\text{mA}$)	λ_{peak}	660	nm
Wavelength at Dominate emission ($I_F=10\text{mA}$)	λ_D	640	nm
Spectral Line half-width ($I_F=10\text{mA}$)	$\Delta\lambda$	20	nm
Capacitance ($V_F=0\text{V}$, $f=1\text{MHz}$)	C	45	pF

Part Number	Emitting Color	Emitting Material	Luminous Intensity ($I_F=10\text{mA}$) ucd		Wavelength nm λ_P	Description
			min.	typ.		
XMMR50A	Red	GaAlAs	12000	25990	660	Column Anode

XMMR50A

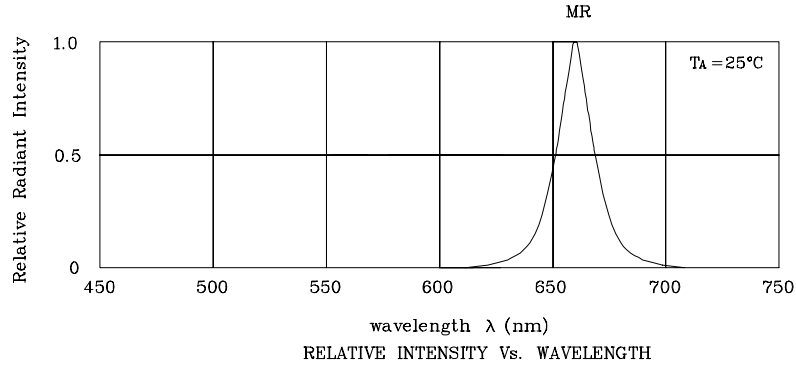

❖MR

