

# 4.8mm RIGHT ANGLE LED INDICATOR



**SUN LED**

XVB1LUY48D

Email : sales@us.sunled.com

Web Site : www.sunled.com

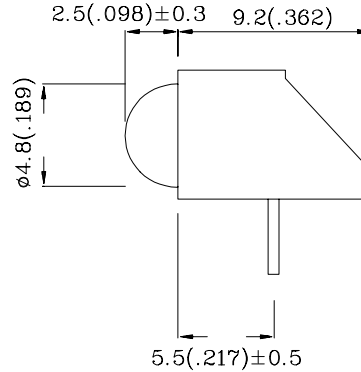
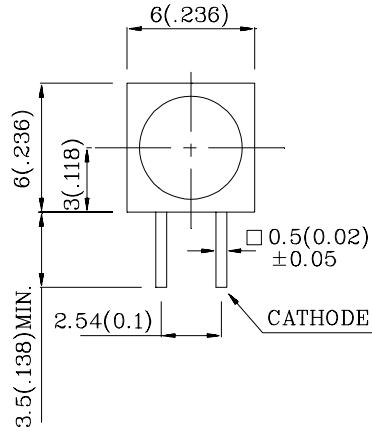

UL RATING : 94V-0.

HOUSING MATERIAL: TYPE 66 NYLON.

**Notes:**

1. All dimensions are in millimeters (inches).
2. Tolerance is  $\pm 0.25(0.01)$ " unless otherwise noted.

Absolute maximum ratings (T <sub>A</sub> =25°C)		UY (GaAsP/GaP)	Unit
Reverse voltage	V <sub>R</sub>	5	V
Forward current	I <sub>F</sub>	30	mA
Forward current (peak) 1/10Duty cycle 0.1ms pulse width	i <sub>FS</sub>	140	mA
Power dissipation	P <sub>T</sub>	105	mW
Operating temperature	T <sub>A</sub>	-40 ~ +85	°C
Storage temperature	T <sub>stg</sub>		
Lead solder temperature [2mm below package base]	260°C For 5 Seconds		

Operating Characteristics (T <sub>A</sub> =25°C)		UY (GaAsP/GaP)	Unit
Forward voltage (typ.) (I <sub>F</sub> =10mA)	V <sub>F</sub>	1.95	V
Forward voltage (max.) (I <sub>F</sub> =10mA)	V <sub>F</sub>	2.5	V
Reverse current (V <sub>R</sub> =5V)	I <sub>R</sub>	10	uA
Wavelength at peak emission (I <sub>F</sub> =10mA)	λ <sub>peak</sub>	590	nm
Wavelength at Dominate emission (I <sub>F</sub> =10mA)	λ <sub>D</sub>	588	nm
Spectral Line half-width (I <sub>F</sub> =10mA)	Δλ	35	nm
Capacitance (V <sub>F</sub> =0V, f=1MHz)	C	20	pF

Part Number	Emitting Color	Emitting Material	Lens-color	Luminous Intensity (I <sub>F</sub> =10mA) mcd		Wavelength nm λ <sub>P</sub>	Viewing Angle 2θ1/2
				min.	typ.		
XVB1LUY48D	Yellow	GaAsP/GaP	Yellow Diffused	5	19	590	60°

**XVB1LUY48D**

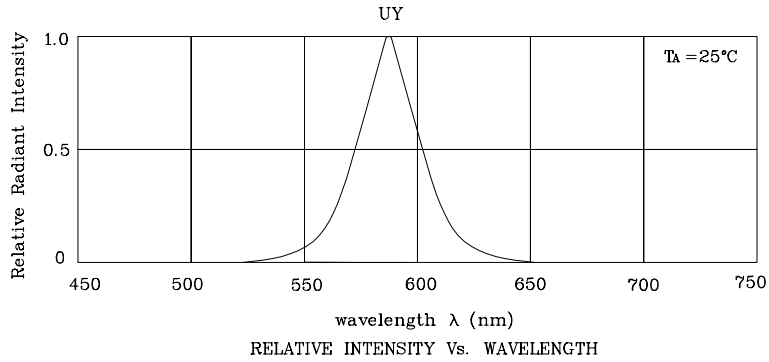

◆UY

