

### 3.0x1.0mm SMD CHIP LED LAMP



# SUNLED

Email : sales@us.sunled.com

Web Site : www.sunled.com

XZAG56W

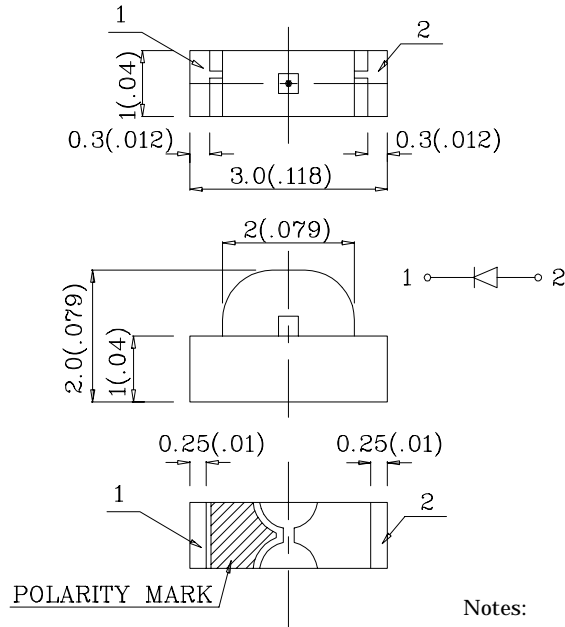

Notes:

1. All dimensions are in millimeters (inches).
2. Tolerance is  $\pm 0.15(0.006)$ " unless otherwise noted.

Absolute maximum ratings ( $T_A=25^\circ\text{C}$ )		AG (InGaN)	Unit
Reverse voltage	$V_R$	5	V
Forward current	$I_F$	30	mA
Forward current (peak) 1/10Duty cycle 0.1ms pulse width	$i_{FS}$	150	mA
Power dissipation	$P_T$	110	mW
Operating temperature	$T_A$	-40 ~ +85	°C
Storage temperature	$T_{stg}$	-40 ~ +85	

Operating Characteristics ( $T_A=25^\circ\text{C}$ )		AG (InGaN)	Unit
Forward voltage (typ.) ( $I_F=20\text{mA}$ )	$V_F$	3.6	V
Forward voltage (max.) ( $I_F=20\text{mA}$ )	$V_F$	4.4	V
Reverse current ( $V_R=5\text{V}$ )	$I_R$	10	$\mu\text{A}$
Wavelength at peak emission ( $I_F=20\text{mA}$ )	$\lambda_{\text{peak}}$	500	nm
Wavelength at Dominate emission ( $I_F=20\text{mA}$ )	$\lambda_D$	505	nm
Spectral Line half-width ( $I_F=20\text{mA}$ )	$\Delta\lambda$	30	nm
Capacitance ( $V_F=0\text{V}$ , $f=1\text{MHz}$ )	$C$	56	pF

Part Number	Emitting Color	Emitting Material	Lens-color	Luminous Intensity ( $I_F=20\text{mA}$ ) mcd		Wavelength nm $\lambda_P$	Viewing Angle $2\theta_{1/2}$
				min.	typ.		
XZAG56W	Green	InGaN	Water Clear	50	85	500	120°

# XZAG56W

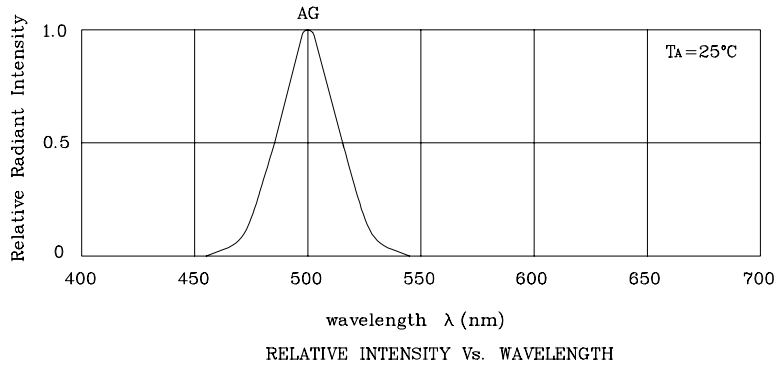

## ◆AG

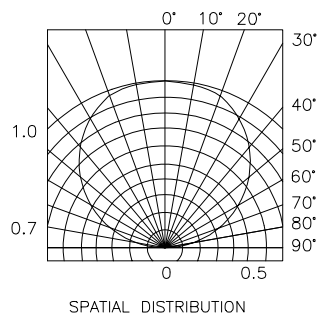
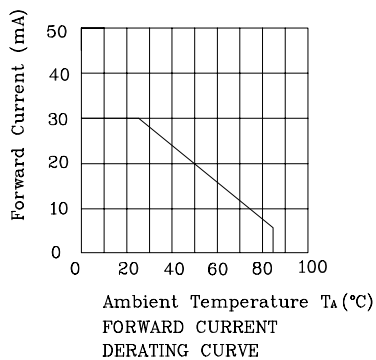
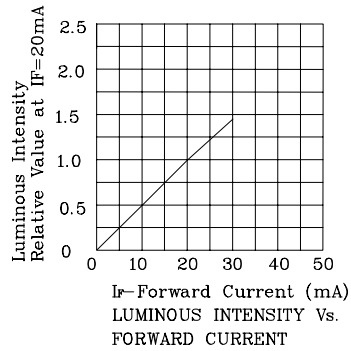
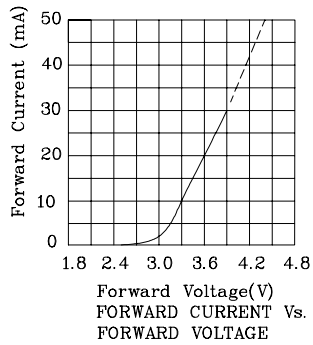

**XZAG56W**  
**❖SMT Reflow Soldering Instructions**

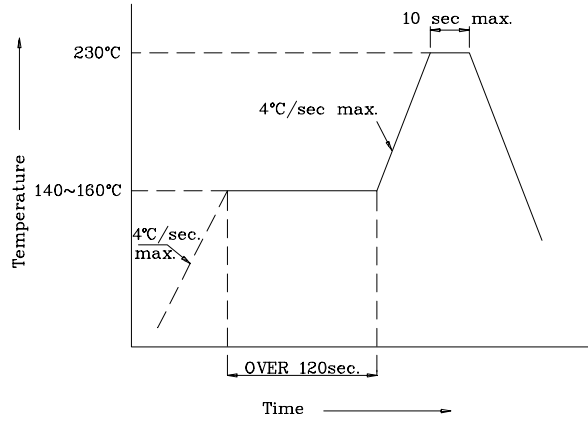

**❖Recommended Soldering Pattern (Units : mm; Tolerance :  $\pm 0.1$ )**

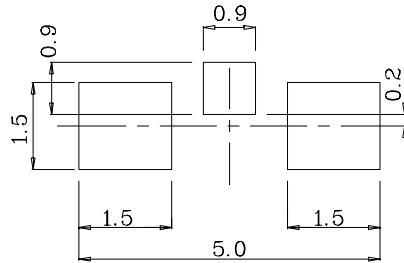

**❖Tape Specification (Units : mm)**

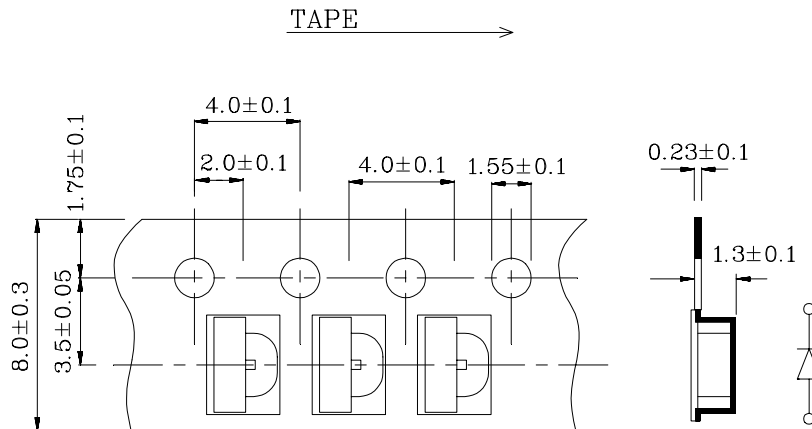

PACKAGE : 2000PCS / REEL.