

# SUBMINIATURE SOLID STATE LAMP



# SUNLED

XZBGK46W-3

Email : sales@us.sunled.com

Web Site : www.sunled.com

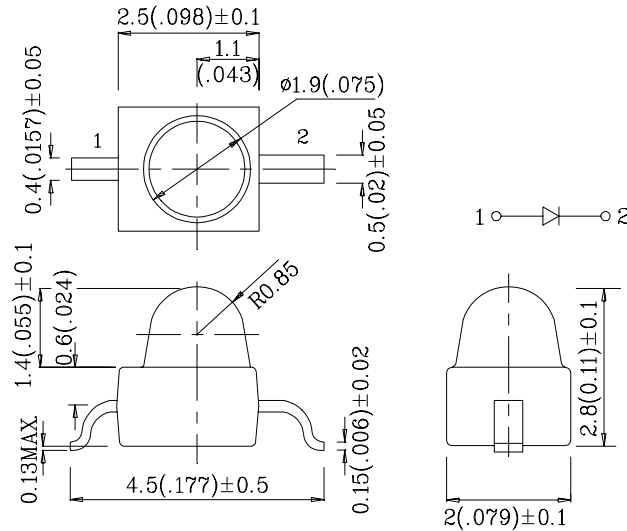

**Notes:**

1. All dimensions are in millimeters (inches).
2. Tolerance is  $\pm 0.25(0.01")$  unless otherwise noted.

Absolute maximum ratings ( $T_A=25^\circ\text{C}$ )		BGK (InGaN)	Unit
Reverse voltage	$V_R$	5	V
Forward current	$I_F$	25	mA
Forward current (peak) 1/10Duty cycle 0.1ms pulse width	$i_{FS}$	130	mA
Power dissipation	$P_T$	105	mW
Operating temperature	$T_A$	-40 ~ +85	°C
Storage temperature	$T_{stg}$	-40 ~ +85	

Operating Characteristics ( $T_A=25^\circ\text{C}$ )		BGK (InGaN)	Unit
Forward voltage (typ.) ( $I_F=20\text{mA}$ )	$V_F$	4.2	V
Forward voltage (max.) ( $I_F=20\text{mA}$ )	$V_F$	4.8	V
Reverse current ( $V_R=5\text{V}$ )	$I_R$	10	uA
Wavelength at peak emission ( $I_F=20\text{mA}$ )	$\lambda_{peak}$	515	nm
Wavelength at Dominate emission ( $I_F=20\text{mA}$ )	$\lambda_D$	525	nm
Spectral Line half-width ( $I_F=20\text{mA}$ )	$\Delta\lambda$	30	nm
Capacitance ( $V_F=0\text{V}$ , $f=1\text{MHz}$ )	$C$	45	pF

Part Number	Emitting Color	Emitting Material	Lens-color	Luminous Intensity ( $I_F=20\text{mA}$ ) mcd		Wavelength nm $\lambda_P$	Viewing Angle $2\theta_{1/2}$
				min.	typ.		
XZBGK46W-3	Green	InGaN	Water Clear	280	595	515	20°

**XZBGK46W-3**

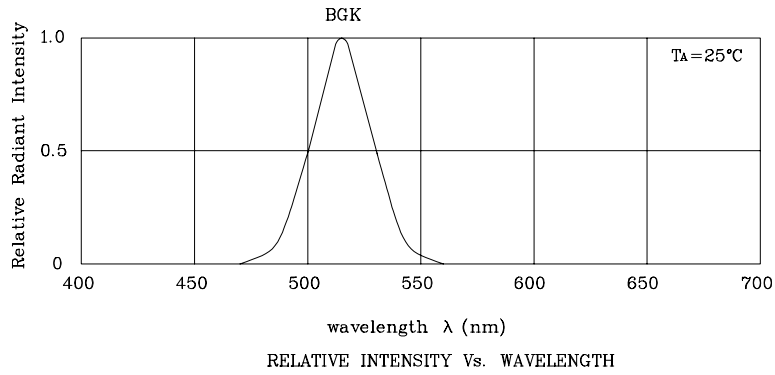

**◆BGK**

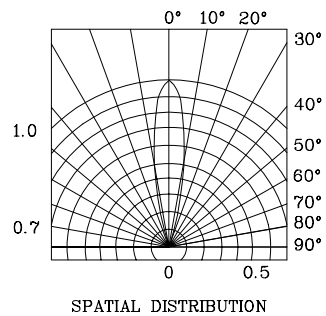
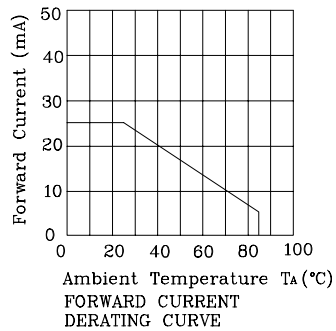
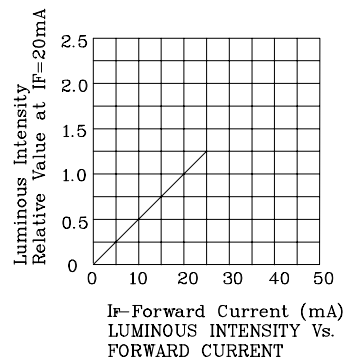
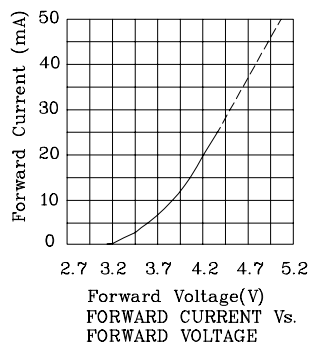

# XZBGK46W-3

## ❖ SMT Reflow Soldering Instructions

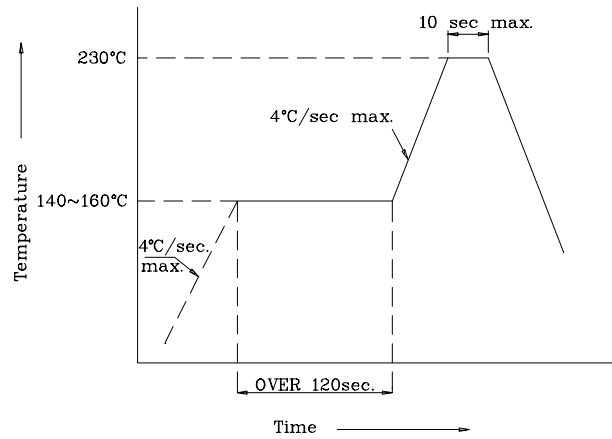

## ❖ Recommended Soldering Pattern (Units : mm; Tolerance: ±0.1)

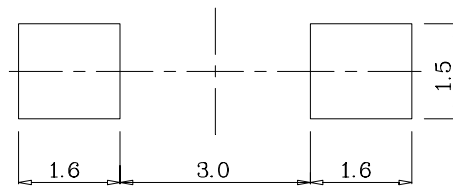

## ❖ Tape Specification (Units : mm)

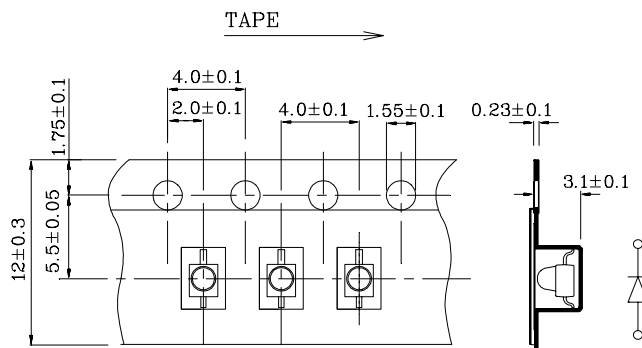

PACKAGE : 1000PCS / REEL.