

SUBMINIATURE SOLID STATE LAMP



SUNLED

Email : sales@us.sunled.com

Web Site : www.sunled.com

XZMR46W-3

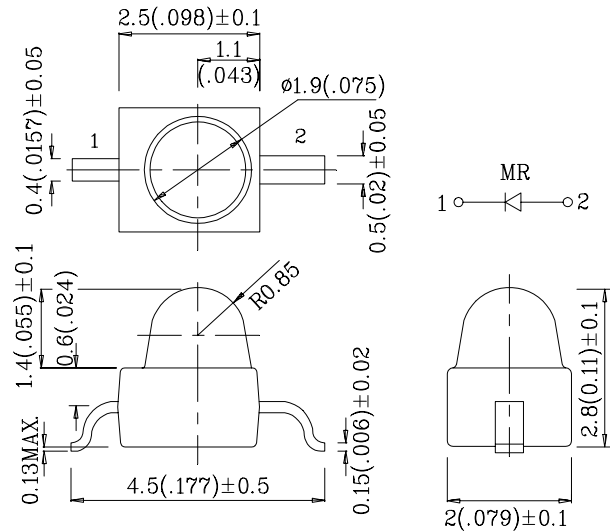

Notes:

1. All dimensions are in millimeters (inches).
2. Tolerance is $\pm 0.25(0.01")$ unless otherwise noted.

Absolute maximum ratings ($T_A=25^\circ\text{C}$)		MR (GaAlAs)	Unit
Reverse voltage	V_R	5	V
Forward current	I_F	30	mA
Forward current (peak) 1/10Duty cycle 0.1ms pulse width	i_{FS}	155	mA
Power dissipation	P_T	100	mW
Operating temperature	T_A	-40 ~ +85	$^\circ\text{C}$
Storage temperature	T_{stg}		

Operating Characteristics ($T_A=25^\circ\text{C}$)		MR (GaAlAs)	Unit
Forward voltage (typ.) ($I_F=20\text{mA}$)	V_F	1.85	V
Forward voltage (max.) ($I_F=20\text{mA}$)	V_F	2.5	V
Reverse current ($V_R=5\text{V}$)	I_R	10	μA
Wavelength at peak emission ($I_F=20\text{mA}$)	λ_{peak}	660	nm
Wavelength at Dominate emission ($I_F=20\text{mA}$)	λ_D	640	nm
Spectral Line half-width ($I_F=20\text{mA}$)	$\Delta\lambda$	20	nm
Capacitance ($V_F=0\text{V}$, $f=1\text{MHz}$)	C	45	pF

Part Number	Emitting Color	Emitting Material	Lens-color	Luminous Intensity ($I_F=20\text{mA}$) mcd		Wavelength nm λ_P	Viewing Angle $2\theta_{1/2}$
				min.	typ.		
XZMR46W-3	Red	GaAlAs	Water Clear	110	595	660	20°

XZMR46W-3

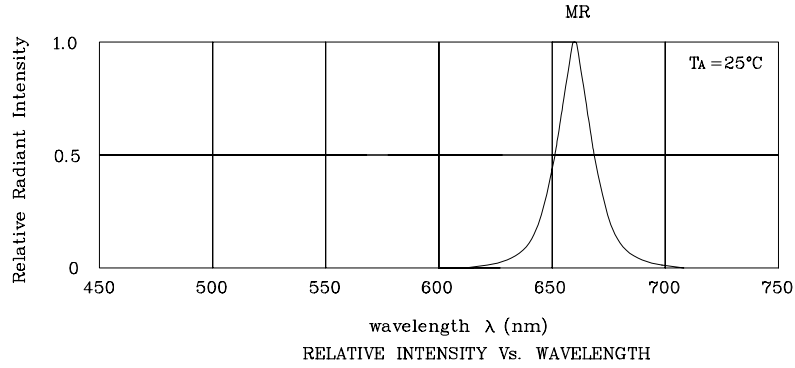

◆MR

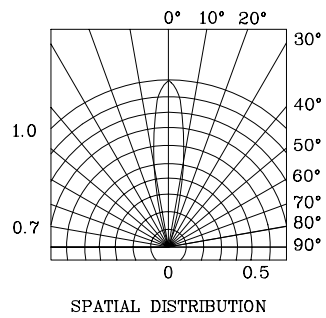
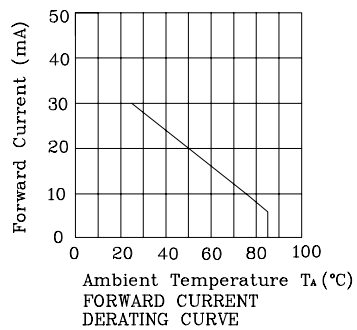
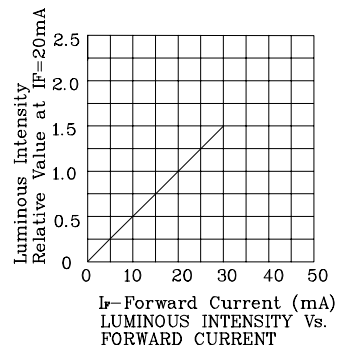
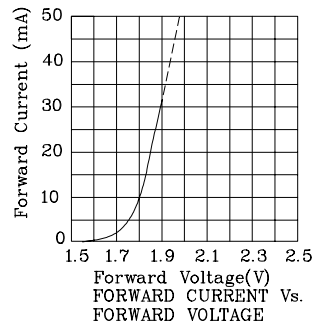

XZMR46W-3

❖ SMT Reflow Soldering Instructions

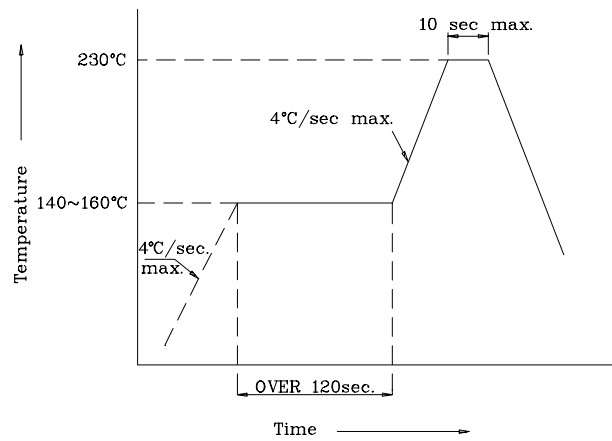

❖ Recommended Soldering Pattern (Units : mm;Tolerance:±0.1)

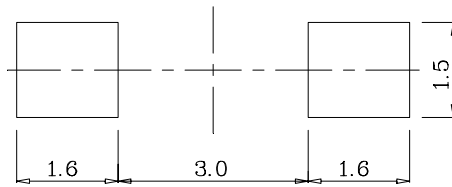

❖ Tape Specification (Units : mm)

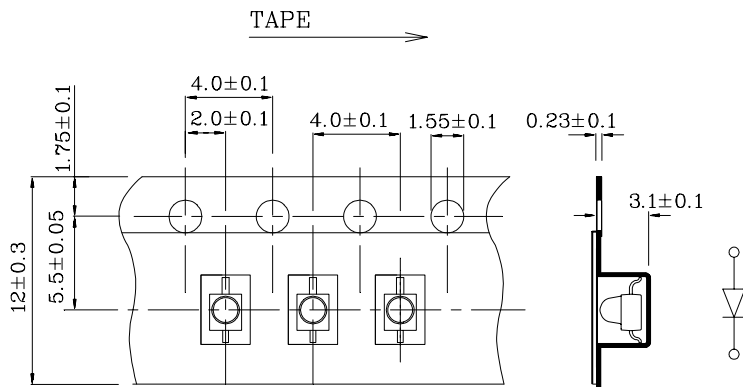

PACKAGE : 1000PCS / REEL.