

4.0mm x1.0mm BACK LIGHT



SUN LED

Email : sales@us.sunled.com

Web Site : www.sunled.com

XZSGK71W

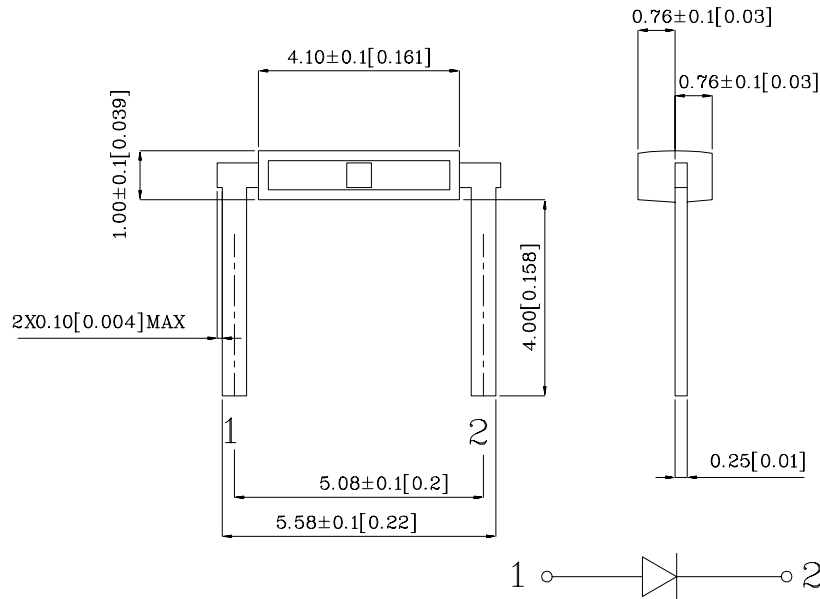

Notes:

1. All dimensions are in millimeters (inches).
2. Tolerance is ±0.25(0.01") unless otherwise noted.

Absolute maximum ratings (T _A =25°C)		SGK (InGaAlP)	Unit
Reverse voltage	V _R	5	V
Forward current	I _F	30	mA
Forward current (peak) 1/10Duty cycle 0.1ms pulse width	i _{FS}	150	mA
Power dissipation	P _T	105	mW
Operating temperature	T _A	-40 ~ +85	°C
Storage temperature	T _{stg}		
Lead solder temperature [2mm below package base]	260°C For 5 Seconds		

Operating Characteristics (T _A =25°C)		SGK (InGaAlP)	Unit
Forward voltage (typ.) (I _F =20mA)	V _F	2.1	V
Forward voltage (max.) (I _F =20mA)	V _F	2.5	V
Reverse current (V _R =5V)	I _R	10	uA
Wavelength at peak emission (I _F =20mA)	λ _{peak}	574	nm
Wavelength at Dominate emission (I _F =20mA)	λ _D	570	nm
Spectral Line half-width (I _F =20mA)	Δλ	20	nm
Capacitance (V _F =0V, f=1MHz)	C	15	pF

Part Number	Emitting Color	Emitting Material	Lens-color	Luminous Intensity (I _F =20mA) mcd		Wavelength nm λ _P	Viewing Angle 2θ1/2
				min.	typ.		
XZSGK71W	Green	InGaAlP	Water Clear	18	59	574	100°

XZSGK71W

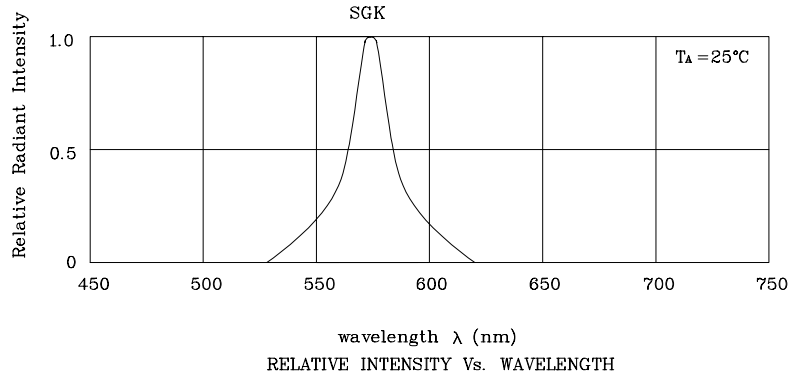

◆SGK

