

2.1x0.7 mm SMD CHIP LED LAMP



SUN LED

XZUB65W

Email : sales@us.sunled.com

Web Site : www.sunled.com

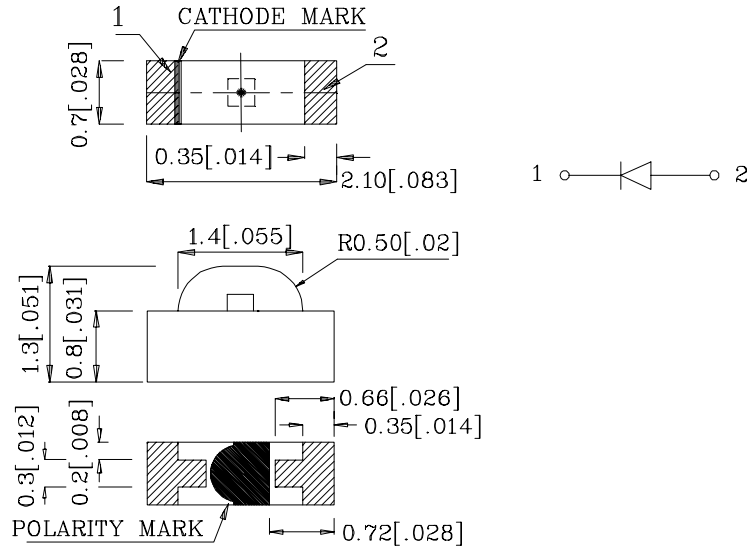

Notes:

1. All dimensions are in millimeters (inches).
2. Tolerance is ± 0.15 (0.006") unless otherwise noted.

Absolute maximum ratings ($T_A=25^\circ\text{C}$)		UB (GaN)	Unit
Reverse voltage	V_R	5	V
Forward current	I_F	30	mA
Forward current (peak) 1/10Duty cycle 0.1ms pulse width	i_{FS}	150	mA
Power dissipation	P_T	105	mW
Operating temperature	T_A	-40 ~ +85	°C
Storage temperature	T_{stg}	-40 ~ +85	

Operating Characteristics ($T_A=25^\circ\text{C}$)		UB (GaN)	Unit
Forward voltage (typ.) ($I_F=20\text{mA}$)	V_F	3.8	V
Forward voltage (max.) ($I_F=20\text{mA}$)	V_F	4.5	V
Reverse current ($V_R=5\text{V}$)	I_R	10	μA
Wavelength at peak emission ($I_F=20\text{mA}$)	λ_{peak}	430	nm
Wavelength at Dominate emission ($I_F=20\text{mA}$)	λ_D	466	nm
Spectral Line half-width ($I_F=20\text{mA}$)	$\Delta\lambda$	60	nm
Capacitance ($V_F=0\text{V}$, $f=1\text{MHz}$)	C	100	pF

Part Number	Emitting Color	Emitting Material	Lens-color	Luminous Intensity ($I_F=20\text{mA}$) mcd		Wavelength nm λ_P	Viewing Angle $2\theta_{1/2}$
				min.	typ.		
XZUB65W	Blue	GaN	Water Clear	2.6	7	430	120°

XZUB65W

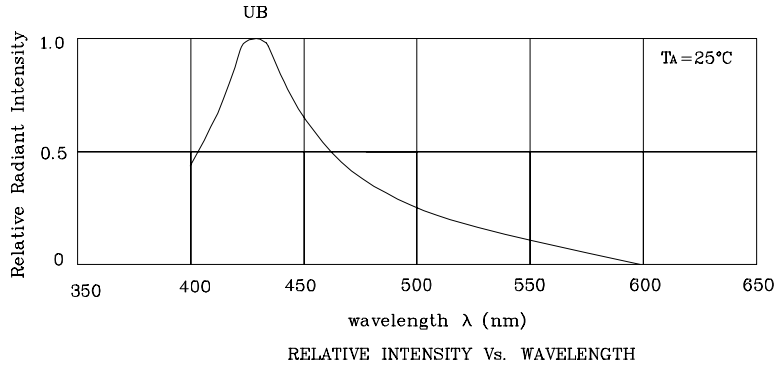

❖UB

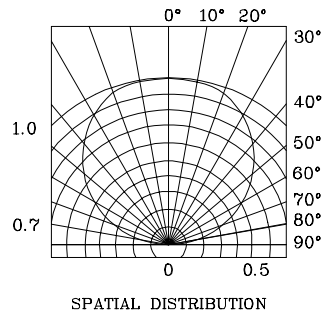
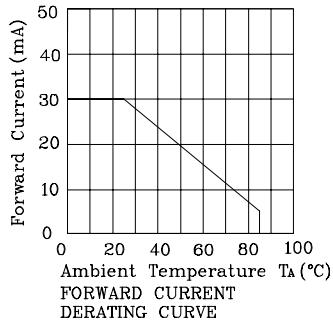
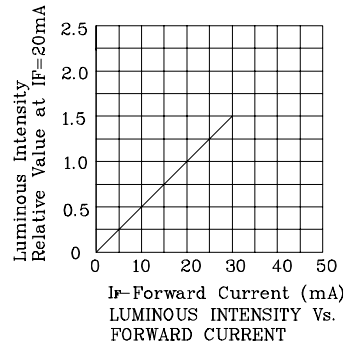
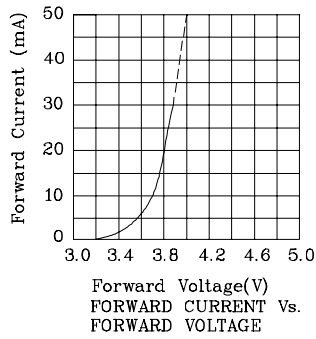

XZUB65W

❖SMT Reflow Soldering Instructions

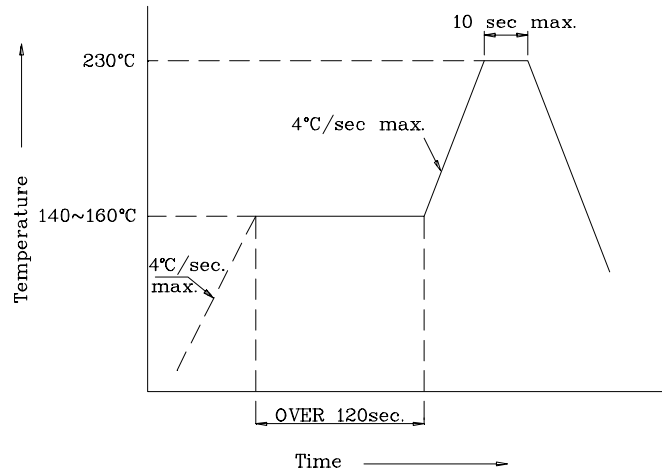

❖Recommended Soldering Pattern (Units : mm; Tolerance : ±0.1)

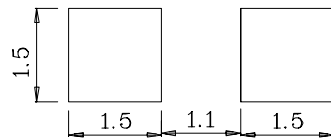

❖Tape Specification (Units : mm)

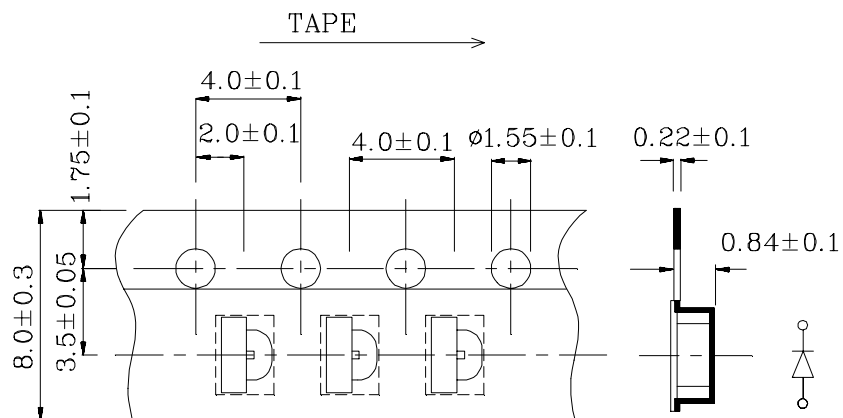

PACKAGE : 2000PCS / REEL.