

## VOLTAGE PROTECTION FOR 2-, 3-, OR 4-CELL Lion BATTERIES (2<sup>ND</sup> PROTECTION)

### FEATURES

- 2-, 3-, or 4-Cell Secondary Protection
- Low Power Consumption  $I_{CC} < 2 \mu A$  [ $V_{CELL(ALL)} < V_{(PROTECT)}$ ]
- High Accuracy Over Sense Voltage:
  - bq29400: 4.35 V  $\pm 25$  mV
  - bq29400A: 4.40 V  $\pm 25$  mV
  - bq29401: 4.45 V  $\pm 25$  mV
  - bq29405: 4.65 V  $\pm 25$  mV
- Prefixed Protection Threshold Voltage
- Programmable Delay Time
- High Power Supply Ripple Rejection
- Stable During Pulse Charge Operation

### APPLICATIONS

- 2<sup>nd</sup> Level Protection in Lion Battery Packs in
  - Notebook PCs
  - Portable Instrumentation
  - Medical and Test Equipment

### DESCRIPTION

The bq29400, bq29400A, bq29401, and bq29405 are BiCMOS secondary protection ICs for 2-, 3-, or 4-cell Lithium-Ion battery packs that incorporate a high-accuracy precision over voltage detection circuit. They include a programmable delay circuit for over voltage detection time.

### FUNCTION

Each cell in a multiple cell pack is compared to an internal reference voltage. If one cell reaches an overvoltage condition, the protection sequence begins. The bq2940x device starts charging an external capacitor through the CD pin. When the CD pin voltage reaches 1.2 V, the OUT pin changes from a low level to a high level.

**PW PACKAGE  
(TOP VIEW)**

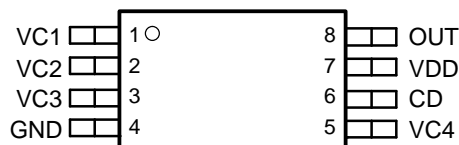

**DCT PACKAGE  
(TOP VIEW)**

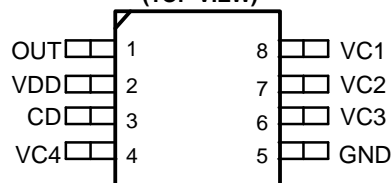

### ORDERING INFORMATION

T <sub>A</sub>	V <sub>(PROTECT)</sub>	PACKAGE			
		MSOP (DTC)	SYMBOL	TSSOP (PW) <sup>(1)</sup>	SYMBOL
–25°C to 85°C	4.35 V	bq29400DCT3	CIQ	bq29400PW	2400
	4.40 V	bq29400ADCT3	CIT	Not Available	-
	4.45 V	bq29401DCT3	CIR	bq29401PW	2401
	4.65 V	bq29405DCT3	CIS	Not Available	-

(1) The bq29400, bq29400A, bq29401, and bq29405 are available taped and reeled. Add an R suffix to the device type (e.g., bq29400PWR) to order tape and reel version.



Please be aware that an important notice concerning availability, standard warranty, and use in critical applications of Texas Instruments semiconductor products and disclaimers thereto appears at the end of this data sheet.



These devices have limited built-in ESD protection. The leads should be shorted together or the device placed in conductive foam during storage or handling to prevent electrostatic damage to the MOS gates.

## ABSOLUTE MAXIMUM RATINGS

over operating free-air temperature range unless otherwise noted<sup>(1)(2)</sup>

		UNIT
Supply voltage range	(VDD)	-0.3 V to 28 V
Input voltage range	(VC1, VC2, VC3, VC4)	-0.3 V to 28 V
	(VC1 to VC2, VC2 to VC3, VC3 to VC4, VC4 to GND)	-0.3 V to 8 V
Output voltage range	(OUT)	-0.3 V to 28 V
	(CD)	-0.3 V to 28 V
Continuous total power dissipation		See Dissipation Rating Table
Storage temperature range, T <sub>stg</sub>		-65°C to 150°C
Lead temperature (soldering, 10 sec)		300°C

- (1) Stresses beyond those listed under "absolute maximum ratings" may cause permanent damage to the device. These are stress ratings only, and functional operation of the device at these or any other conditions beyond those indicated under "recommended operating conditions" is not implied. Exposure to absolute-maximum-rated conditions for extended periods may affect device reliability.
- (2) All voltages are with respect to ground of this device except the differential voltage of VC1-VC2, VC2-VC3, VC3-VC4 and VC4-GND.

## PACKAGE DISSIPATION RATINGS

PACKAGE	T <sub>A</sub> ≤ 25°C POWER RATING	DERATING FACTOR ABOVE T <sub>A</sub> = 25°C	T <sub>A</sub> = 70°C POWER RATING	T <sub>A</sub> = 85°C POWER RATING
DCT	412 mW	3.3 mW/°C	264 mW	214 mW
PW	525 mW	4.2 mW/°C	336 mW	273 mW

## RECOMMENDED OPERATING CONDITIONS

		MIN	NOM	MAX	UNIT
V <sub>DD</sub>	Supply Voltage	4.0	25		V
V <sub>I</sub>	Input voltage range	VC1, VC2, VC3, VC4		0	V <sub>DD</sub>
		VC <sub>n</sub> – VC(n+1), (n=1, 2, 3), VC4-GND		0	5.0
t <sub>d(CD)</sub>	Delay time capacitance		0.22		μF
R <sub>IN</sub>	Voltage-monitor filter resistance	100	1k		Ω
C <sub>IN</sub>	Voltage-monitor filter capacitance	0.01	0.1		μF
R <sub>VD</sub>	Supply-voltage filter resistance	0		100	Ω
C <sub>VD</sub>	Supply-voltage filter capacitance		0.1		μF
T <sub>A</sub>	Operating ambient temperature range	-25		85	°C

## ELECTRICAL CHARACTERISTICS

over recommended operating free-air temperature range,  $T_A = 25^\circ\text{C}$  (unless otherwise noted)<sup>(1)</sup>

PARAMETER		TEST CONDITION	MIN	NOM	MAX	UNIT
$V_{(OA)}$	Over voltage detection accuracy			25	35	mV
		$T_A = -20^\circ\text{C}$ to $85^\circ\text{C}$		25	50	
$V_{(PROTECT)}$	Over voltage detection voltage <sup>(1)</sup>	bq29400		4.35		V
		bq2940A		4.40		
		bq29401		4.45		
		bq29405		4.65		
$V_{hys}$	Over voltage detection hysteresis <sup>(1)</sup>			300		mV
$I_i$	Input current	$V_2, V_3, VC_4$ input $VC_1 = VC_2 = VC_3 = VC_4 = 3.5\text{ V}$ (see Figure 1)			$\pm 0.3$	$\mu\text{A}$
$t_{D1}$	Over voltage detection delay time	$CD = 0.22\ \mu\text{F}$	1.0	1.5	2.0	S
$I_{(CD\_dis)}$	CD GND clamp current	$CD = 1\text{ V}$	5	12		$\mu\text{A}$
$I_{CC}$	Supply current	$VC_1 = VC_2 = VC_3 = VC_4 = 3.5\text{ V}$ (see Figure 1)		2.0	3.0	$\mu\text{A}$
		$VC_1 = VC_2 = VC_3 = VC_4 = 2.3\text{ V}$ (see Figure 1)		1.5	2.5	
$V_{(OUT)}$	OUT pin drive voltage	$VC_1 = VC_2 = VC_3 = VC_4 = 4.7\text{ V}$ , $IOH = 0\text{ mA}$		7		V
$I_{OH}$	High-level output current	$OUT = 3\text{V}$ , $VC_1 = VC_2 = VC_3 = VC_4 = 4.7\text{ V}$	-1			mA
$I_{OL}$	Low-level output current	$OUT = 0.1\text{ V}$ $VC_1 = VC_3 = VC_4 = 3.5\text{ V}$	5			$\mu\text{A}$

(1) Levels of the over-voltage detection and the hysteresis can be adjusted. For assistance contact Texas Instruments sales representative.

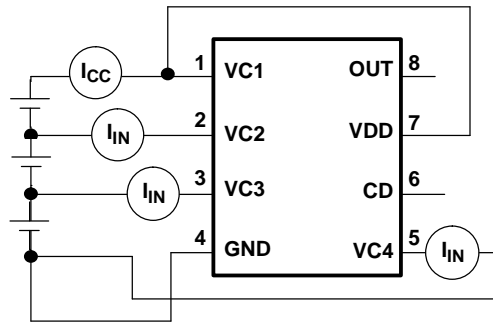
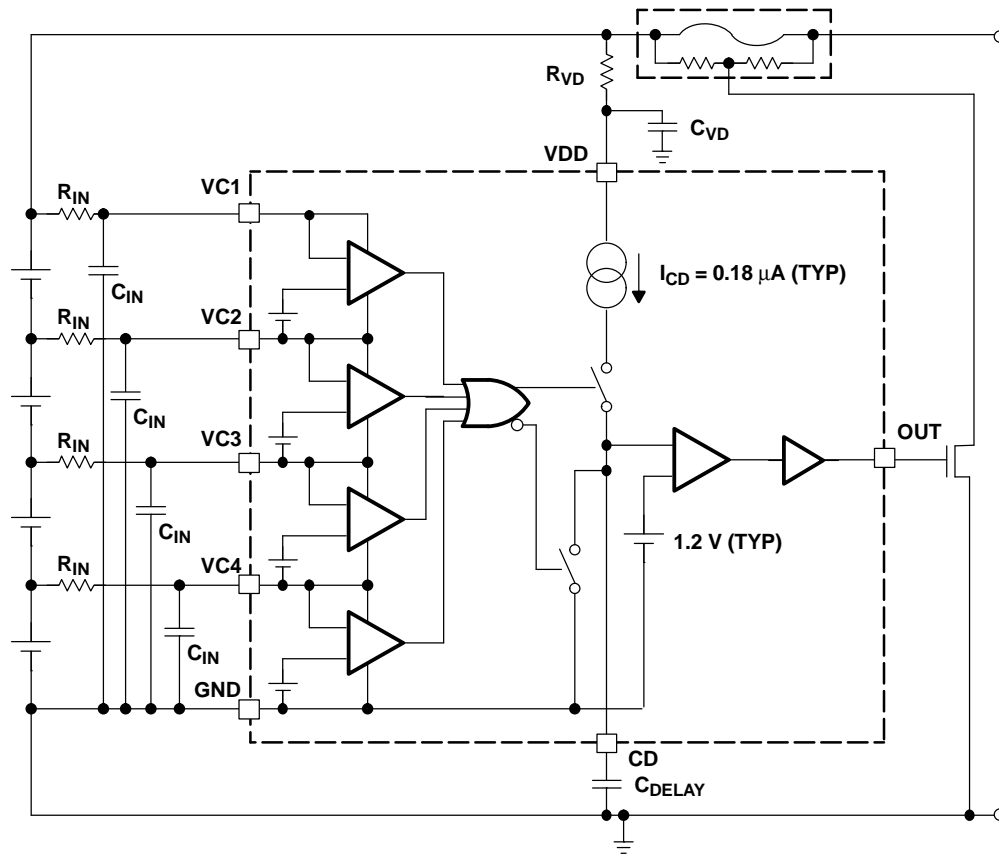

Figure 1.  $I_{CC}$ ,  $I_{IN}$  Measurement (TSSOP Package)

### Terminal Functions

TERMINAL No.			DESCRIPTION
MSOP (DTC)	TSSOP (PW)	NAME	
8	1	VC1	Sense voltage input for most positive cell
7	2	VC2	Sense voltage input for second most positive cell
6	3	VC3	Sense voltage input for third most positive cell
5	4	GND	Ground pin
4	5	VC4	Sense voltage input for least positive cell
3	6	CD	An external capacitor is connected to determine the programmable delay time
2	7	VDD	Power supply
1	8	OUT	Output

### FUNCTIONAL BLOCK DIAGRAM



### OVERVOLTAGE PROTECTION

When one of the cell voltages exceeds  $V_{(PROTECT)}$ , an internal current source begins to charge the capacitor,  $C_{(DELAY)}$ , connected to the CD pin. If the voltage at the CD pin,  $V_{CD}$ , reaches 1.2 V, the OUT pin is activated and transitions high. An externally connected NCH FET is activated and blows the external fuse in the positive battery rail, see Figure 1.

If all cell voltages fall below  $V_{(PROTECT)}$  before the voltage at pin CD reaches 1.2 V, the delay time does not run out. An internal switch clamps the CD pin to GND and discharges the capacitor,  $C_{(DELAY)}$ , and secures the full delay time for the next occurring overvoltage event.

Once the pin OUT is activated, it transitions back from high to low after all battery cells reach  $V_{(PROTECT)} - V_{hys}$ .

### DELAY TIME CALCULATION

The delay time is calculated as follows:

$$t_d = \frac{1.2 \text{ V} \times C_{(DELAY)}}{I_{CD}}$$

$$C_{(DELAY)} = \frac{t_d \times I_{CD}}{1.2 \text{ V}}$$

Where  $I_{(CD)}$  = CD current source = 0.18  $\mu\text{A}$

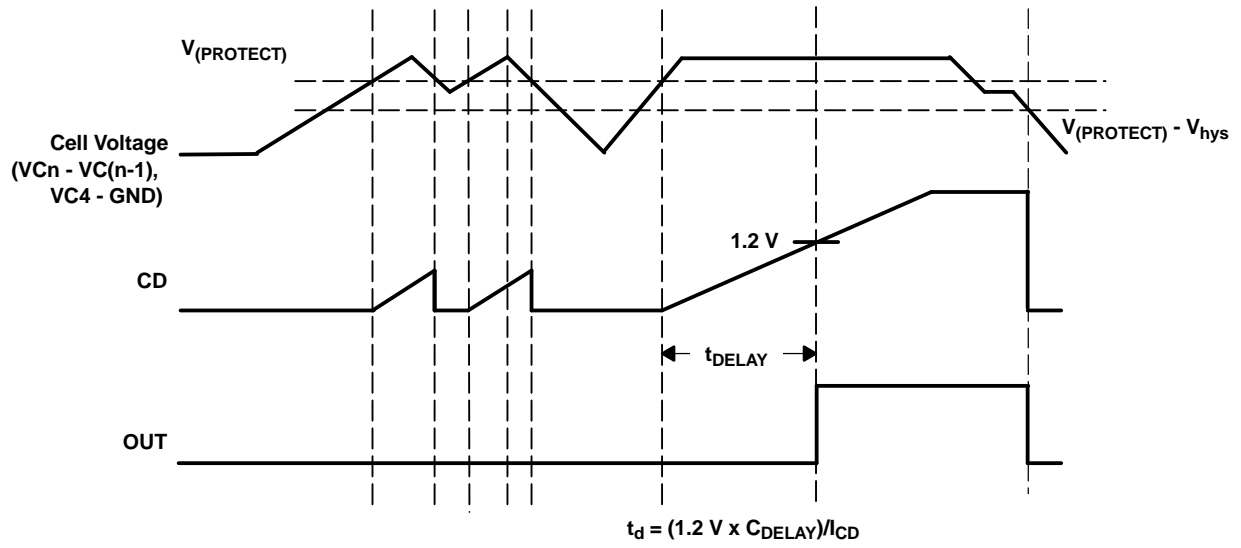

**Figure 2. Timing for Overvoltage Sensing**

## APPLICATION INFORMATION

### BATTERY CONNECTIONS

The following diagrams show the TSSOP package device in different cell configurations.

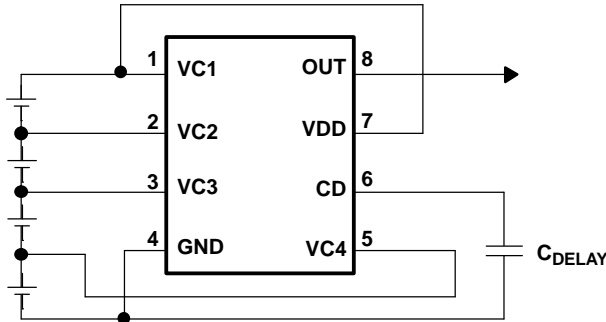

Figure 3. 4-Series Cell Configuration

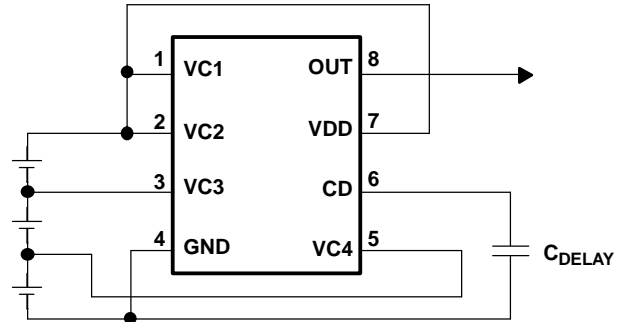

Figure 4. 3-Series Cell Configuration  
(Connect together VC1 and VC2)

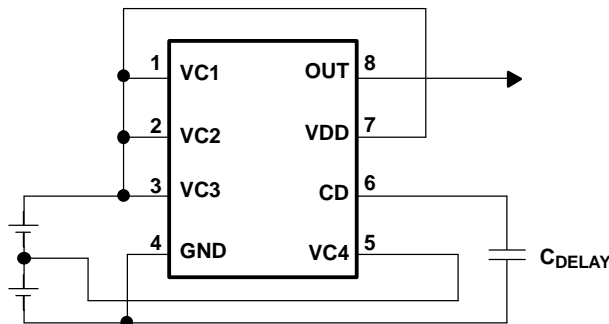

Figure 5. 2-Series Cell Configuration (Connect together VC1, VC2, and VC3)

### CELL CONNECTIONS

To prevent incorrect output activation the following connection sequences must be used.

#### 4-Series Cell Configuration

- VC1(=VDD) → VC2 → VC3 → VC4 → GND or
- GND → VC4 → VC3 → VC2 → VC1(=VDD)

#### 3-Series Cell Configuration

- VC1(=VC2=VDD) → VC3 → VC4 → GND or
- GND → VC4 → VC3 → VC1(=VC2=VDD)

#### 2-Series Cell Configuration

- VC1(=VC2=VC3=VDD) → VC4 → GND or
- GND → VC4 → VC1(=VC2=VC3=VDD)

**PACKAGING INFORMATION**

Orderable Device	Status <sup>(1)</sup>	Package Type	Package Drawing	Pins	Package Qty	Eco Plan <sup>(2)</sup>	Lead/Ball Finish	MSL Peak Temp <sup>(3)</sup>
BQ29400ADCT3	ACTIVE	SM8	DCT	8	3000	Pb-Free (RoHS)	CU SNBI	Level-1-250C-UNLIM
BQ29400ADCT3R	ACTIVE	SM8	DCT	8	3000	TBD	Call TI	Call TI
BQ29400PW	ACTIVE	TSSOP	PW	8	150	TBD	CU NIPDAU	Level-1-220C-UNLIM
BQ29400PWR	ACTIVE	TSSOP	PW	8	2000	TBD	CU NIPDAU	Level-1-220C-UNLIM
BQ29401DCT	PREVIEW	SM8	DCT	8		TBD	Call TI	Call TI
BQ29401DCTR	PREVIEW	SM8	DCT	8	3000	TBD	Call TI	Call TI
BQ29401PW	ACTIVE	TSSOP	PW	8	150	TBD	CU NIPDAU	Level-1-220C-UNLIM
BQ29401PWR	ACTIVE	TSSOP	PW	8	2000	TBD	CU NIPDAU	Level-1-220C-UNLIM
BQ29405DCT3	ACTIVE	SM8	DCT	8	3000	Pb-Free (RoHS)	CU SNBI	Level-1-250C-UNLIM
BQ29405DCT3R	PREVIEW	SM8	DCT	8	3000	TBD	Call TI	Call TI

<sup>(1)</sup> The marketing status values are defined as follows:

**ACTIVE:** Product device recommended for new designs.

**LIFEBUY:** TI has announced that the device will be discontinued, and a lifetime-buy period is in effect.

**NRND:** Not recommended for new designs. Device is in production to support existing customers, but TI does not recommend using this part in a new design.

**PREVIEW:** Device has been announced but is not in production. Samples may or may not be available.

**OBsolete:** TI has discontinued the production of the device.

<sup>(2)</sup> Eco Plan - The planned eco-friendly classification: Pb-Free (RoHS) or Green (RoHS & no Sb/Br) - please check <http://www.ti.com/productcontent> for the latest availability information and additional product content details.

**TBD:** The Pb-Free/Green conversion plan has not been defined.

**Pb-Free (RoHS):** TI's terms "Lead-Free" or "Pb-Free" mean semiconductor products that are compatible with the current RoHS requirements for all 6 substances, including the requirement that lead not exceed 0.1% by weight in homogeneous materials. Where designed to be soldered at high temperatures, TI Pb-Free products are suitable for use in specified lead-free processes.

**Green (RoHS & no Sb/Br):** TI defines "Green" to mean Pb-Free (RoHS compatible), and free of Bromine (Br) and Antimony (Sb) based flame retardants (Br or Sb do not exceed 0.1% by weight in homogeneous material)

<sup>(3)</sup> MSL, Peak Temp. -- The Moisture Sensitivity Level rating according to the JEDEC industry standard classifications, and peak solder temperature.

**Important Information and Disclaimer:**The information provided on this page represents TI's knowledge and belief as of the date that it is provided. TI bases its knowledge and belief on information provided by third parties, and makes no representation or warranty as to the accuracy of such information. Efforts are underway to better integrate information from third parties. TI has taken and continues to take reasonable steps to provide representative and accurate information but may not have conducted destructive testing or chemical analysis on incoming materials and chemicals. TI and TI suppliers consider certain information to be proprietary, and thus CAS numbers and other limited information may not be available for release.

In no event shall TI's liability arising out of such information exceed the total purchase price of the TI part(s) at issue in this document sold by TI to Customer on an annual basis.





PW (R-PDSO-G\*\*)

PLASTIC SMALL-OUTLINE PACKAGE

14 PINS SHOWN



4040064/F 01/97

- NOTES: A. All linear dimensions are in millimeters.  
 B. This drawing is subject to change without notice.  
 C. Body dimensions do not include mold flash or protrusion not to exceed 0,15.  
 D. Falls within JEDEC MO-153

## IMPORTANT NOTICE

Texas Instruments Incorporated and its subsidiaries (TI) reserve the right to make corrections, modifications, enhancements, improvements, and other changes to its products and services at any time and to discontinue any product or service without notice. Customers should obtain the latest relevant information before placing orders and should verify that such information is current and complete. All products are sold subject to TI's terms and conditions of sale supplied at the time of order acknowledgment.

TI warrants performance of its hardware products to the specifications applicable at the time of sale in accordance with TI's standard warranty. Testing and other quality control techniques are used to the extent TI deems necessary to support this warranty. Except where mandated by government requirements, testing of all parameters of each product is not necessarily performed.

TI assumes no liability for applications assistance or customer product design. Customers are responsible for their products and applications using TI components. To minimize the risks associated with customer products and applications, customers should provide adequate design and operating safeguards.

TI does not warrant or represent that any license, either express or implied, is granted under any TI patent right, copyright, mask work right, or other TI intellectual property right relating to any combination, machine, or process in which TI products or services are used. Information published by TI regarding third-party products or services does not constitute a license from TI to use such products or services or a warranty or endorsement thereof. Use of such information may require a license from a third party under the patents or other intellectual property of the third party, or a license from TI under the patents or other intellectual property of TI.

Reproduction of information in TI data books or data sheets is permissible only if reproduction is without alteration and is accompanied by all associated warranties, conditions, limitations, and notices. Reproduction of this information with alteration is an unfair and deceptive business practice. TI is not responsible or liable for such altered documentation.

Resale of TI products or services with statements different from or beyond the parameters stated by TI for that product or service voids all express and any implied warranties for the associated TI product or service and is an unfair and deceptive business practice. TI is not responsible or liable for any such statements.

Following are URLs where you can obtain information on other Texas Instruments products and application solutions:

<b>Products</b>		<b>Applications</b>	
Amplifiers	<a href="http://amplifier.ti.com">amplifier.ti.com</a>	Audio	<a href="http://www.ti.com/audio">www.ti.com/audio</a>
Data Converters	<a href="http://dataconverter.ti.com">dataconverter.ti.com</a>	Automotive	<a href="http://www.ti.com/automotive">www.ti.com/automotive</a>
DSP	<a href="http://dsp.ti.com">dsp.ti.com</a>	Broadband	<a href="http://www.ti.com/broadband">www.ti.com/broadband</a>
Interface	<a href="http://interface.ti.com">interface.ti.com</a>	Digital Control	<a href="http://www.ti.com/digitalcontrol">www.ti.com/digitalcontrol</a>
Logic	<a href="http://logic.ti.com">logic.ti.com</a>	Military	<a href="http://www.ti.com/military">www.ti.com/military</a>
Power Mgmt	<a href="http://power.ti.com">power.ti.com</a>	Optical Networking	<a href="http://www.ti.com/opticalnetwork">www.ti.com/opticalnetwork</a>
Microcontrollers	<a href="http://microcontroller.ti.com">microcontroller.ti.com</a>	Security	<a href="http://www.ti.com/security">www.ti.com/security</a>
		Telephony	<a href="http://www.ti.com/telephony">www.ti.com/telephony</a>
		Video & Imaging	<a href="http://www.ti.com/video">www.ti.com/video</a>
		Wireless	<a href="http://www.ti.com/wireless">www.ti.com/wireless</a>

Mailing Address: Texas Instruments  
Post Office Box 655303 Dallas, Texas 75265