

Vishay

## Universal Constant Current Control 1 Channel and 2 Channels The Smallest and Low Profile Constant Current Control 0 - 2.0A, up to 35V, with 170W/in<sup>3</sup> Power Density and High Efficiency

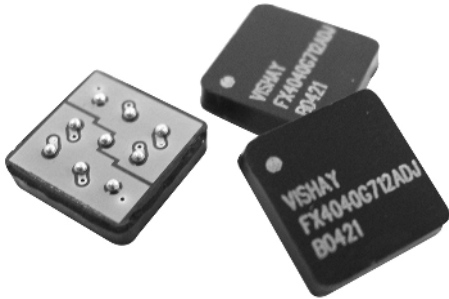

### FEATURES

- Fully integrated Universal Constant Current Control LED driver
- Power density - more than 170W/inch<sup>3</sup>
- Controlled output current
- BGA construction
- Temperature range: - 40°C to + 85°C
- No external components required
- Output power 60W per channel
- 2 totally independent channels
- Maximum current 2.0A per channel
- Low profile

The Universal Constant Current Control is a 1&2 channel driver dedicated for optimum performance to drive Power LED s. FX4040 is a complete adjustable system solution for all Power LED s with high current from 20mA up to 2A. The FX4040 provides a constant current without exceeding the applicable LED voltage to ensure the specified LED load life time. The integrated Universal Constant Current Control provides flexibility of utilizing various battery configurations and chemistries such as NiCd, NiMH, or Li+ and fixed power supplies with input voltage up to 35v. An additional flexibility is provided by using external resistors adjusting the constant output current to various LED configurations.

The FX4040 Universal Constant Current Control is available in 9-ports BGA package. In order to satisfy the stringent ambient temperature requirements, the Universal Constant Current Control is designed to handle the industrial temperature range of - 40°C to + 85°C.

### APPLICATION

- LED lighting
- Backlight
- Bike lamps
- Positioning with LASER LEDs
- UV LEDs for ink drying
- Infrared LEDs
- Headlights and flashlights
- Medical instrumentation
- General and emergency/alarm lighting
- Design and architectural lighting
- Interior and runway lights
- Outdoor accent lighting
- Household appliances

### CIRCUIT IDENTIFIER

CIRCUIT IDENTIFIER	TYPE	MAX INPUT VOLTAGE	MAX INPUT VOLTAGE WITH ADDITIONAL CAP.*
G711	SINGLE	20V	35V
G721	DOUBLE	20V	35V

\*Note: For input voltage higher than 20V, a 10µF capacitor (35V rating minimum) must be connected between points R<sub>0</sub> and V<sub>L</sub>

### ORDERING INFORMATION

FX	4040	G7XX	ADJ	<input type="checkbox"/>	<input type="checkbox"/>
FUNCTION					
SIZE					
CIRCUIT IDENTIFIER					
OUTPUT VOLTAGE - ADJ for adjustable version - self selectable output voltage. (see note below)					
PACKAGING - B1 = 10pcs in bulk; B5 = 50pcs in bulk; T1 = 1000pcs in 13" reel; T2 = 250pcs in 7" reel.					
For lead (Pb)-free solder please add E2 suffix.					

\* Note: for fixed output current please contact [FunctionPAK@vishay.com](mailto:FunctionPAK@vishay.com)

<b>DIMENSIONS</b> in inches [millimeters]	
<b>L</b>	0.40 ± 0.01 [10 ± 0.25]
<b>A</b>	0.1 ± 0.01 [2.54 ± 0.25]
<b>B</b>	0.05 ± 0.01 [1.19 ± 0.25]
<b>T</b>	0.11 max [2.8 max]
<b>Ball Diameter</b>	0.03 ± 0.001 [0.762 ± 0.025]

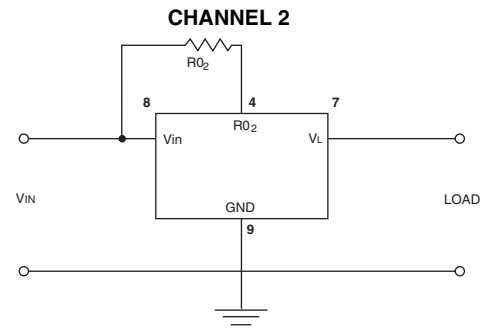
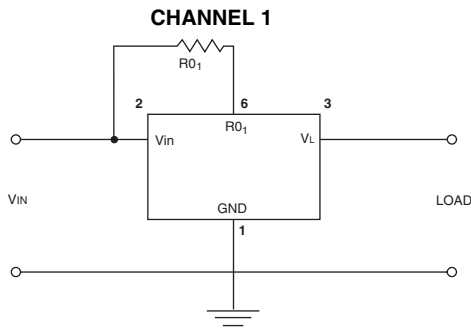
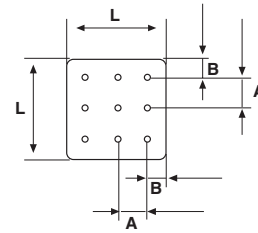
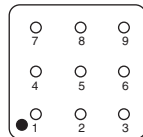
**UPPER SIDE**

**PIN CONFIGURATION**

CONFIGURATION	SINGLE COMPONENT	DOUBLE COMPONENT CHANNEL 1	DOUBLE COMPONENT CHANNEL 2
	PIN	PIN	PIN
GND	1	1	9
V <sub>in</sub>	2	2	8
V <sub>L</sub>	3	3	7
R0*	6	6	4
NC	4, 5, 7 - 9	5	5

\* Note: R0 can be already built in on request.

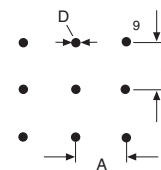
<b>RECOMMENDED PAD PATTERN</b> in inches [millimeters]	
<b>A</b>	<b>D</b>
0.1 ± 0.01 [2.54 ± 0.25]	0.03 ± 0.001 [0.8 ± 0.02]



STANDARD ELECTRICAL SPECIFICATIONS					
PARAMETER	UNIT	CONDITION	MINIMUM	TYPICAL	MAXIMUM
<b>Input</b> Voltage G711/G721	V <sub>DC</sub>			20	35
<b>Insulation</b> Test Voltage Resistance Leakage Current	V <sub>AC</sub> Ω nA	60Hz 60sec V <sub>ISO</sub> = 500 V <sub>DC</sub> V <sub>ISO</sub> = 500 V <sub>DC</sub>	750 1 x 10 <sup>11</sup>		5
<b>Output</b> W <sub>D</sub> * = (V <sub>in</sub> - V <sub>L</sub> ) I <sub>L</sub>	W	for 1 component at 25°C ambient temperature			1.2
	W	for 1 component at 85°C ambient temperature			0.8
	W	for 2 components at 25°C ambient temperature			1.2
	W	for 2 components at 85°C ambient temperature			0.8
Power (V <sub>L</sub> x I <sub>L</sub> )	W	at V <sub>in</sub> - V <sub>L</sub> = 0.65V			60
V <sub>in</sub> - V <sub>L</sub>	V	input and output voltage gap			20
Voltage G711	V <sub>DC</sub>			17	30
Temp at max. power	°C	above 25°C ambient temperature			120
Voltage G721	V <sub>DC</sub>			17	30
Temp. at max. power	°C	above 25°C ambient temperature			120
Current	A				2
Current Tolerance	%	at 25°C ambient temperature	- 10 %		+ 10 %
<b>General</b> Package Weight	gr.				0.5
<b>Temperature</b> Operation Storage Operating Junction Temp. Thermal Impedance	°C °C °C °C/W <sub>D</sub> *	T <sub>j</sub> θ <sub>JA</sub>	- 40 - 55	150 82	+ 85 + 125

\*Note: W<sub>D</sub> = Power Dissipated

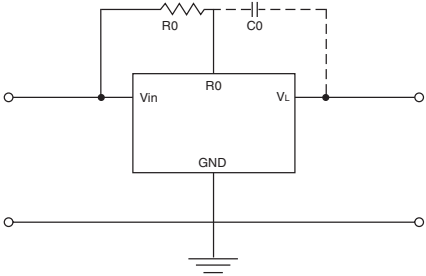
PIN DESCRIPTION	
	
PIN	DESCRIPTION
Vin	Input supply voltage
GND	Ground
R0	To be added externally for self selected output current.  $R_0 = \frac{V_{in} - V_L - 0.55}{I_{out}}$
VL	Output current. LED connection

**DEMONSTRATION BOARD**
**TEST SET-UP AND OPERATION**

1. Connect the DB according to the circuit drawing below without connecting the LED
2. Use DC power supply, with at least capability of 40V; 2A.
3. For applying up to 35V input voltage please add 10 $\mu$ F (at least 35V rating) between points R<sub>0</sub> and V<sub>L</sub>.
4. Connect R<sub>0</sub> resistor between points V<sub>in</sub> and R<sub>0</sub>.
5. Adjust R<sub>0</sub> to full CCW.
6. Connect the LED or equivalent resistor value according to the circuit drawing below.
7. Adjust power supply to a minimum of 1V above the LED voltage\*.
8. Increase R<sub>0</sub> value by adjusting it CW. See how the output current rises.

\*note:  $W_D^{**} = (V_{in} - V_L) I_L < 1.5W$

$V_{in} - V_L = < 20V$

\*\*WD = Power Dissipation

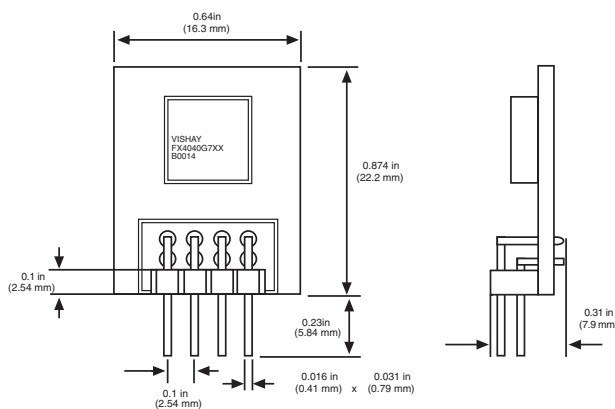
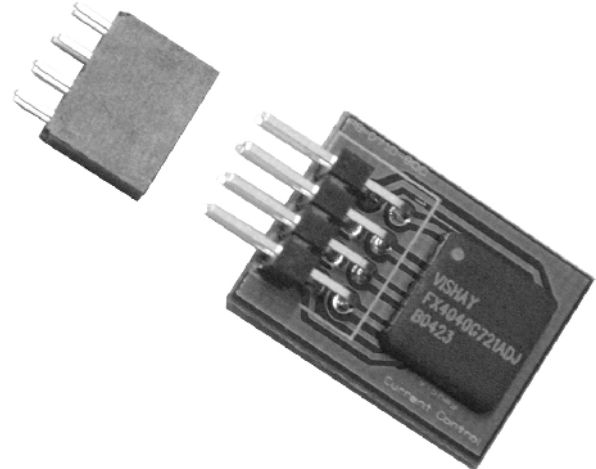
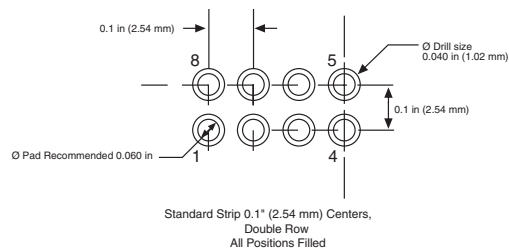
**RECOMMENDED BOARD LAYOUT**

**View from bottom side**

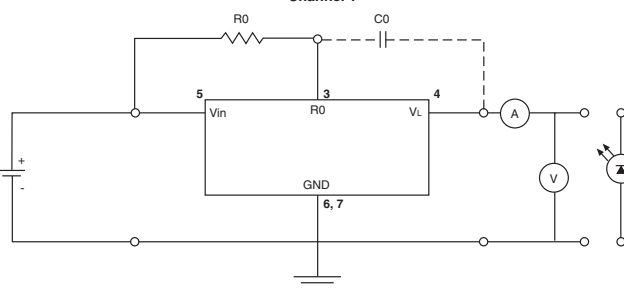
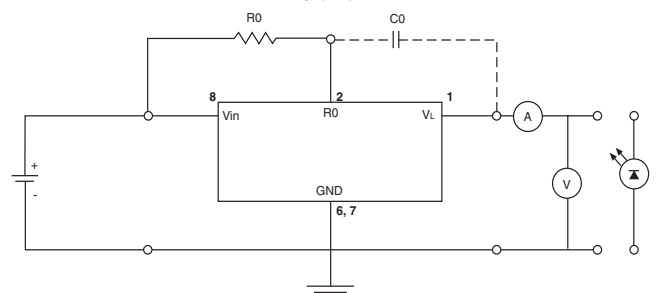
Configuration	Single Component	Double Component Channel 1	Double Component Channel 2
	Pin	Pin	Pin
GND		6, 7	
V <sub>in</sub>	5	5	8
V <sub>L</sub>	4	4	1
R <sub>0</sub>	3	3	2

**Channel 1**

**Channel 2**

## SOLDERING PROFILE

All of the components must be dried prior to assembly as follows:

1. Samples and package type B1 and B5, bulk components - the recommended drying process is to be done at 125°C for 48 hours.
2. For package type T5 - per JEDEC J-STD-033 level 5.

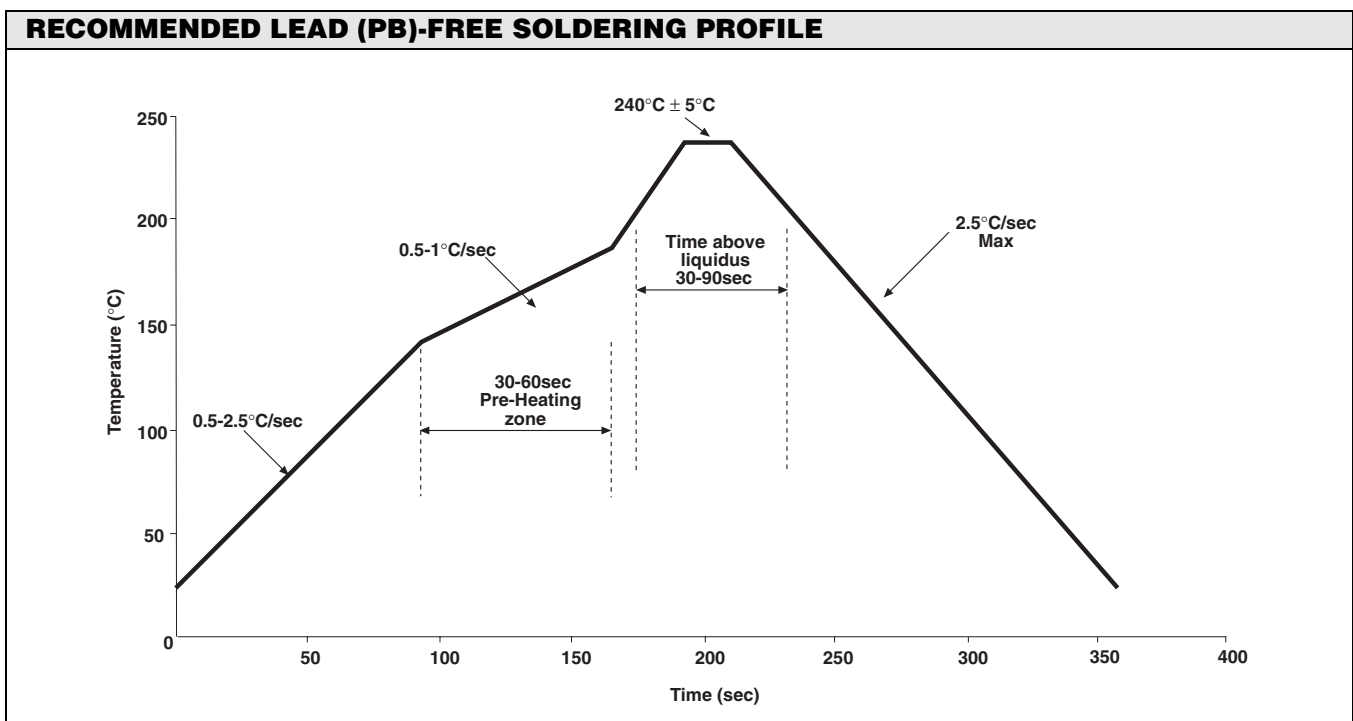
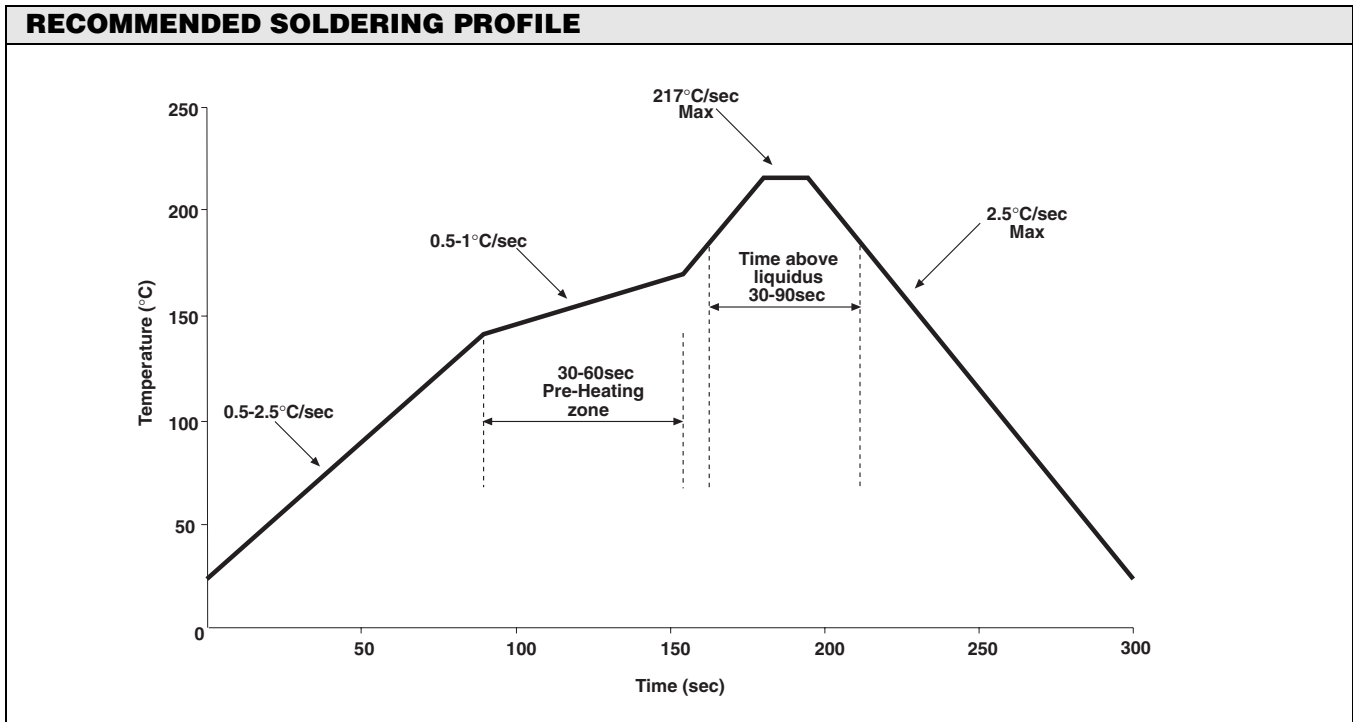
For taped components the recommended drying process is to be done at maximum 70°C.



**TAPE AND REEL INFORMATION**

**PER STANDARD EIA-481-2-A  
(REVISION OF 481-2 AND INCLUSION OF EIA-481-3)**

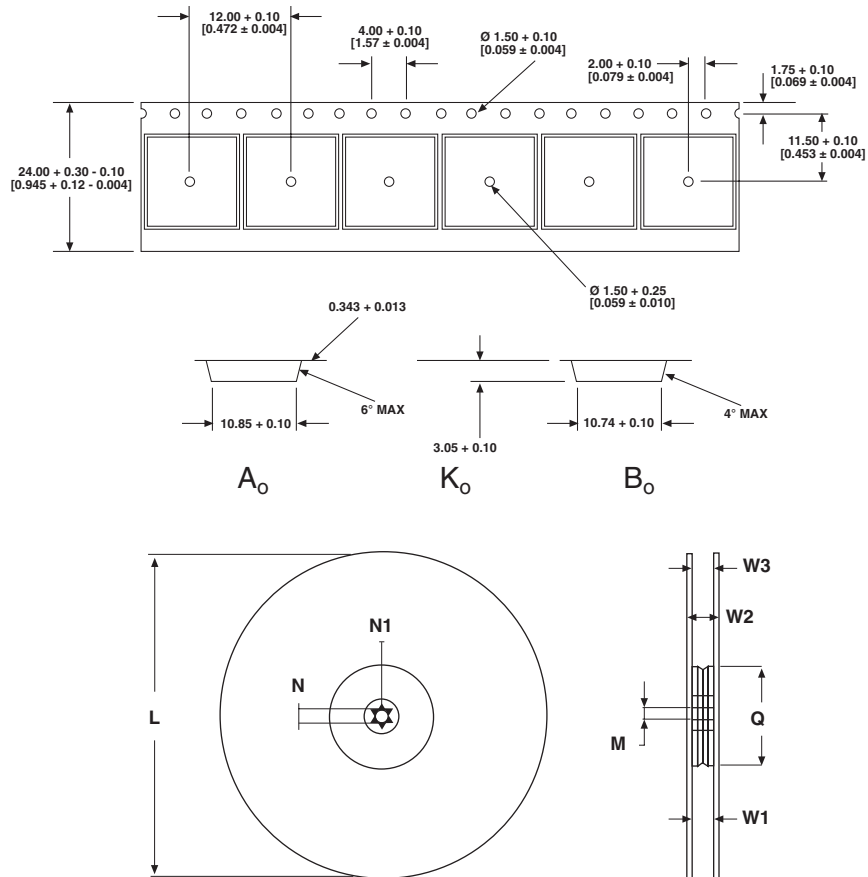
**REEL DIMENSIONS** in millimeters

DIMENSION	MIN	MAX	DIMENSION	MIN	MAX
L		330	L	176	180
M	12.8	13.2	M	12.8	13.2
N	20.2		N	20.2	
N1	1.5		N1	1.5	
Q	100		Q	50	65
W1	24.4	26.4	W1	24.4	26.4
W2		30.4	W2		30.4
W3		27.4	W3		27.4