

# Ultra High Performance BGA Cooling Solutions w/ maxiGRIP™ Attachment\*

DIGI-KEY PART # **ATS1078-ND**

ATS PART # ATS-51425K-C2-R0

## Features & Benefits

maxiFLOW™ design features a low profile, spread fin array that maximizes surface area for more effective convection (air) cooling

maxiGRIP™ attachment applies steady, even pressure to the component and does not require holes in the PCB

Meets Telcordia GR-63-Core Office Vibration; ETSI 300 019 Transportation Vibration; and MIL-STD-810 Shock and Unpackaged Drop Testing standards

Comes preassembled with high performance thermal interface material

Designed for low profile components from 1.5 to 2.99mm

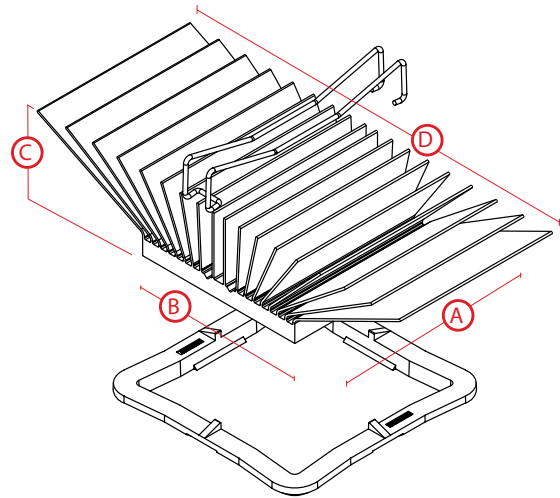

## Thermal Performance Table

AIR VELOCITY		THERMAL RESISTANCE	
FT/MIN	M/S	°C/W (UNDUCTED)	°C/W (DUCTED)
200	1.0	2.4	1.8
300	1.5	1.9	
400	2.0	1.6	
500	2.5	1.5	
600	3.0	1.3	
700	3.5	1.2	
800	4.0	1.2	

## Product Details†

DIMENSION A	DIMENSION B	DIMENSION C§	DIMENSION D	TIM‡	FINISH
42.5	42.5	14.5	72.84	C675	BLACK-ANODIZED

For further technical information, please contact Advanced Thermal Solutions, Inc. at **1-781-769-2800** or [www.qats.com](http://www.qats.com)

\* RoHS Compliant

‡ TIM = Thermal Interface Material

† Dimensions are measured in millimeters

◆ Dimensions A & B refer to component size

§ Dimension C = the height of the heat sink shown above and does not include the height of the attachment method



**ATS** ADVANCED THERMAL SOLUTIONS, INC.

Innovations in Thermal Management®



To place an order, please visit [www.digikey.com](http://www.digikey.com)