

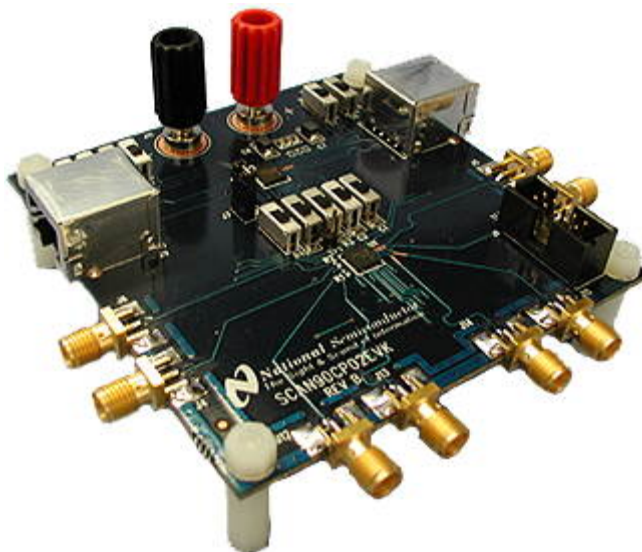

SCAN90CP02
2x2 LVDS Cross-point Switch
Evaluation Kit
(RoHS Compliant)
Documentation



Rev2.3
November 07, 2006

Introduction

National Semiconductor's System Test Access Products Group provides this evaluation kit of the SCAN90CP02 to help demonstrate the use and performance of the device.

The user must supply 3.3-volt power to the Evaluation board. The user also must provide the proper LVDS signal levels to the inputs of the device using a signal generator.

Overview

This Evaluation board uses two SCAN90CP02 devices. Device U1 uses SMA connectors for both the non-inverting and inverting differential input and output signals for each channel (total of 8 SMA connectors for U1). This enables the use of high speed signals for evaluating the performance of the LVDS signal path. Inputs are terminated with 100Ω .

Device U2 may be used for both high speed LVDS evaluations and IEEE 1149.6 evaluations. Channel 0 of device U2 uses CAT5 connectors for the input and output signals to allow the use of "lossy" or inexpensive CAT5 cables as the interconnect medium. Inputs are terminated with 100Ω .

Channel 1 of device U2 is used primarily for IEEE 1149.6 evaluations. The output of Channel 1 is looped back to the inputs of Channel 1 through a fault network. Thus, the fault network may be exercised while monitoring the effects through the IEEE 1149.1 port at J1. Switches S1 thru S5 are used to insert faults for evaluating the IEEE 1149.6 features (refer to the table 2 and figure 2 below).

Additionally, U2 may be configured as a switch, and a high speed signal may be passed thru the fault network. This enables the evaluation of interconnect faults on the LVDS signal integrity.

Switches S6 thru S11 are used as control inputs for both U1 and U2. Switches are provided for the SELx inputs, for the Enable inputs, and the PEMxx inputs to define the output pre-emphasis levels (refer to table 1 and figure 1 below).

For more details, refer to the attached schematic and the SCAN90CP02 datasheet.

Table 1: Control Switch Functions (applies to both U1 and U2)

Silkscreen	Connections	Notes
S11 DISABLE 0	U1, U2 EN0*	Up position disables channel 0 on both devices.
S8 DISABLE 1	U1 EN1*	Up position disables channel 1 on U1.
J7	U2 EN1*	Open position disables channel 1 on U2.
S10 Sel0 S9 Sel1	U1, U2 Sel0 U1, U2 Sel1	Configures both U1 and U2 functionality. Up = 1 down = 0 See datasheet for function table.
S7 PEMX0 S6 PEMX1	U1, U2 PEM00-PEM10 U1, U2 PEM01-PEM11	Configures pre-emphasis feature on both devices and both channels. Up = 1 Down = 0 See datasheet for function table.

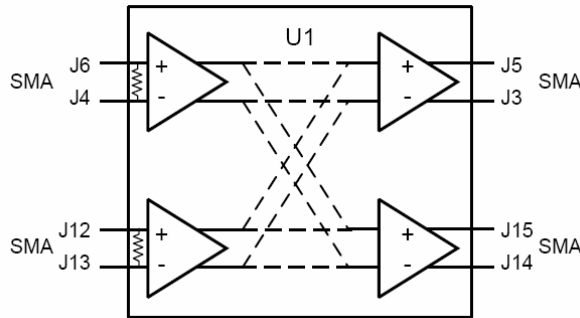

Figure 1: U1 Block Diagram

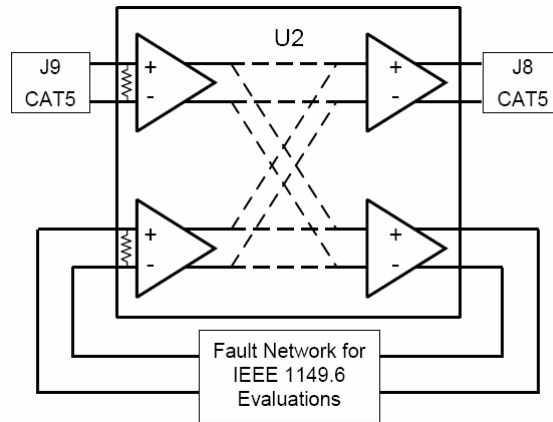
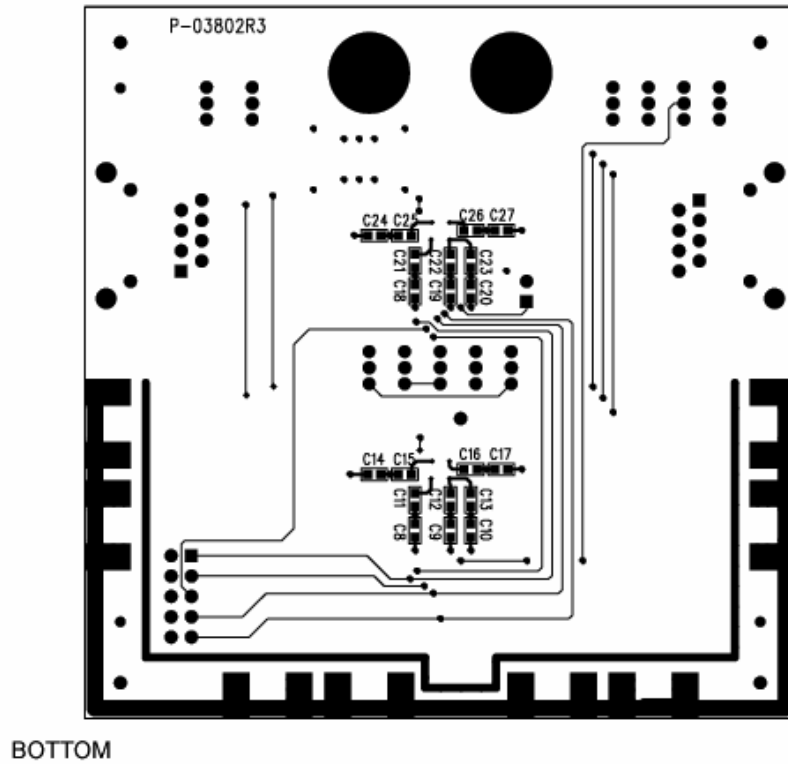
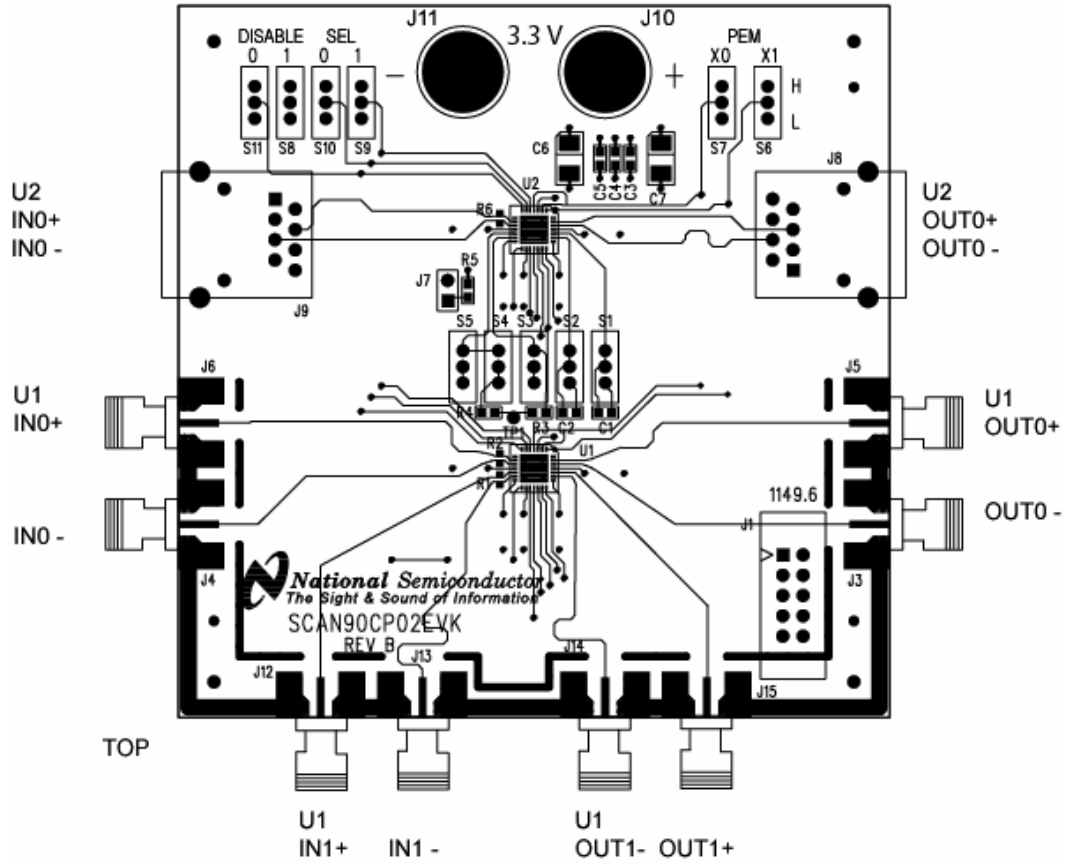

Figure 2: U2 Block Diagram

Table 2: IEEE-1149.1 and IEEE-1149.6 (applies only to U2)

Silkscreen	Function	Notes
J1 1149.6	IEEE 1149.1 test bus access to 1149.6 features	U1 is the first device in the scan chain; U2 is the last device in the scan chain. TDO, TMS, TCK, /TRST (out) are from the test system to the device/chain under test. TDI (in) is from the device/chain under test to the test system.
S1	Short C1	Up position to short coupling capacitor.
S2	Short C2	Up position to short coupling capacitor.
S3	Open	Down position to create open circuit.
S4	Open	Down position to create open circuit at termination resistor.
S5	Open Termination Resistor	Down position to create open circuit.

SCAN90CP02EVK EVALUATION BOARD



6

5

4

3

2

1

REVISION RECORD			
LTR:	ECO NO:	APPROVED:	DATE:
1	1811	ACF	10/24/03
2	1871	ACF	12/8/03
3	1922	ACF	1/13/03

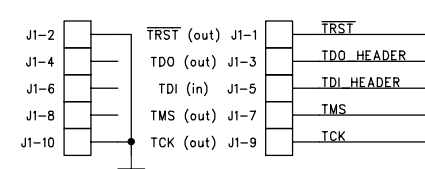
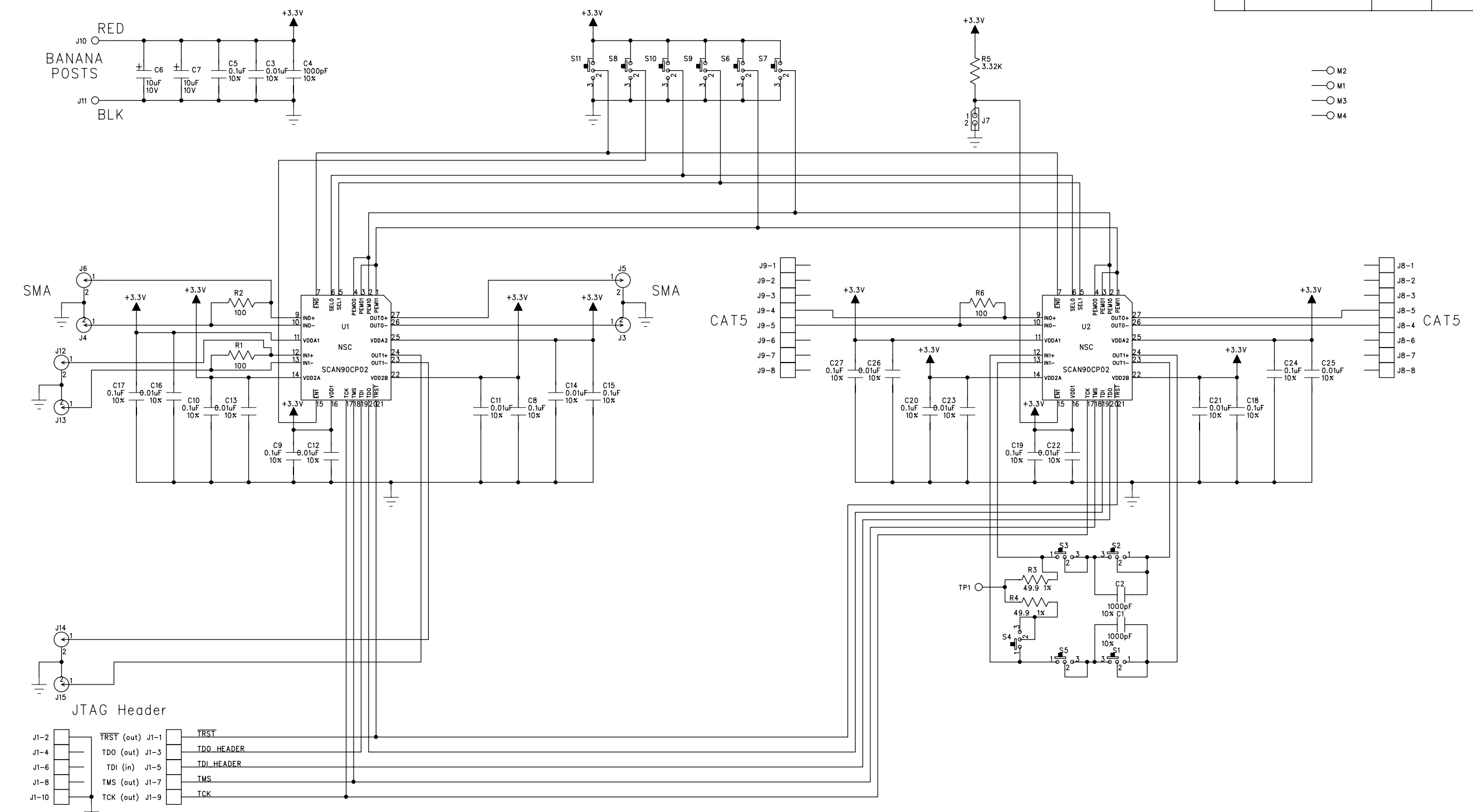

SILKSCREEN	FUNCTION
J1 1149.6	To configure a test chain
J7	U2 EN1*
S1	Short C1
S2	Short C2
S3	Open
S4	Open Termination Resistor
S5	Open
S8 DISABLE 1	U1 EN1*
S7 PEMX0	U1,U2 PEM00-PEM10
S6 PEMX1	U1, U2 PEM01-PEM11
S9 Sel1	U1, U2 Sel1
S10 Sel0	U1, U2 Sel0
S11 DISABLE 0	U1, U2 EN0*

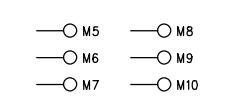

Note: This document is considered uncontrolled unless stamped otherwise.

 25 NorthBrook Drive Gray, Maine 04039 U.S.A.	COMPANY: National Semiconductor	
	TITLE: SCAN90CP02 EVAL PCB SCHEMATIC	
DRAWN: EBALLOU	DATED: 08/12/03	CODE: C
CHECKED:	DATED:	SIZE: S-03832
QUALITY CONTROL:	DATED:	DRAWING NO: S-03832
RELEASED:	DATED:	REV: 3
SCALE: n/a		SHEET: 1 OF 1

D

C

B

A

D

C

B

A

ENERCON - BILL OF MATERIALS	TITLE: NATIONAL SEMICONDUCTOR PCBA, SCAN90CP02EVK EVAL, ROHS	PL Number: Z3015-01	Rev: 2	Rev By: AF	Rev Date: 10/26/2006	PL Status: Released
		Main Product: PCBA, JTAG SCANCP02 EVAL, ROHS		Responsible Eng/Mgr: Ed Ballou	Creator: Arlene Fox	Creation Date: 10/2/2006

Item	Part Type	Part Number/Value	Mfg	NoSub	Description	Qty	SMT	Ref Des	Notes	Re
1	PCB	P-05399R0			SCAN09CP02 EVAL ROHS: 3.50x3.50x.062in, 4 layer	1			Bd: (88.90x88.90mm) Panel: (5.50x10.50in) (139.70x266.70mm) 3 bds/panel	
2										
3	IC	SCAN90CP02SP	NAT		1.5 GBPS LVDS Crosspoint Switch, LLP28	2	X	U1-2	CUSTOMER SUPPLIED	
4										
5	RES	ERJ-3EKF3321	PANA		3.32K 1/10W ±1% 0603, Pb-Free	1	X	R5		
	<ALT>	CRCW06033K32FKEA	VISHAY		3.32K 1/10W ±1% 0603 100ppm, Pb-Free					
	<ALT>	RK73H1JTTD3321F	KOA		3.32K 1/10W ±1% 0603 100ppm, Pb-Free					
6	RES	ERJ-3EKF49R9V	PANA		49.9 Ohm 1/10W ±1% 0603 100ppm, Pb-Free	2	X	R3,4		
	<ALT>	CRCW060349R9FKEA	VISHAY		49.9 Ohm 1/10W ±1% 0603 100ppm					
	<ALT>	RK73H1JTTD49R9F	KOA		49.9 Ohm 1/10W ±1% 0603 100ppm, Pb-Free					
7	RES	ERJ-2RKF1000	PANA		100 Ohm 1/16W ±1% 0402 100ppm, Pb-Free	3	X	R1,2,6		
	<ALT>	ERJ-S02F1000	PANA		100 Ohm 1/16W ±1% 0402 200ppm, Pb-Free					
8										
9	CAP	06035A102KAT	AVX		1000pF, 50V, ±10%, 0603, Ceramic, NP0, Pb-Free	3	X	C1-2,4		
	<ALT>	C0603C102J5GAC	KEMET		1000pF, 50V, ±5%, 0603, Ceramic, NP0, Pb-Free					
10	CAP	06035C103KAT	AVX		.01µF, 50V, ±10%, 0603, Ceramic, X7R, Pb-Free	11	X	C3,11-14,16,21-23,25-26	Mount On Bottom C11-14,16,21,22,23,25,26	
	<ALT>	C0603C103K5RAC	KEMET		.01µF, 50V, ±10%, 0603, Ceramic, X7R, Pb-Free					
11	CAP	0603YC104KAT	AVX		.1µF, 16V, ±10%, 0603, Ceramic, X7R, Pb-Free	11	X	C5,8-10,15,17-20,24,27	Mount on Bottom C8-10,15,17-20,24,27	

ENERCON - BILL OF MATERIALS	TITLE: NATIONAL SEMICONDUCTOR PCBA, SCAN90CP02EVK EVAL, ROHS	PL Number: Z3015-01	Rev: 2	Rev By: AF	Rev Date: 10/26/2006	PL Status: Released
	Main Product: PCBA, JTAG SCANCP02 EVAL, ROHS	Responsible Eng/Mgr: Ed Ballou	Creator: Arlene Fox	Creation Date: 10/2/2006		

Item	Part Type	Part Number/Value	Mfg	NoSub	Description	Qty	SMT	Ref Des	Notes	Re
	<ALT>	C0603C104K4RAC	KEMET		.1µF, 16V, ±10%, 0603, Ceramic, X7R, Pb-Free					
12	CAP	TAJB106M010	AVX		10µF, 10V, ±20%, B-Case, Tantalum, Pb-Free	2	X	C6-7		
	<ALT>	T491B106K010AT	KEMET		10µF, 10V, ±10%, B-Case, Tantalum, Pb-Free					
13										
14	SW	EG1249	ESWITCH		Slide, SPDT, Pb-Free	11		S1-11	Remove Mounting Tabs Prior to Assembly	
15										
16	CONN	5103309-1	AMP		Header, 10p, Male, Dual Row, .100"sp, Pb-Free	1		J1		
17	CONN	142-0711-821	JOH		SMA, 50 Ohm, End Launch, Pb-Free	8		J3-6,12-15		
18	CONN	2560SU00001	LEOCO		Shunt, .100"sp, Pb-Free	1		J7		
	<ALT>	71363-202LF	FCI		Shunt, .100"sp, Gold, Pb-Free					
	<ALT>	SNT-100-BK-G	SAMTEC		Shunt, .100"sp, Gold, Pb-Free					
	<ALT>	SNT-100-BK-H	SAMTEC		Shunt, .100"sp, Gold, Pb-Free					
19	CONN	7006	KEYSTONE		Binding Post, Red, Pb-Free	1		J10		
20	CONN	7007	KEYSTONE		Binding Post, Black, Pb-Free	1		J11		
21	CONN	85505-0013	MOLEX		Telco, 8p, R/A, Shielded, CAT5, Pb-Free	2		J8-9		
22	CONN	TSW-101-07-G-S	SAMTEC		Header, 1p, Male, Gold, Pb-Free	1		TP1		
23	CONN	TSW-102-07-G-S	SAMTEC		Header, 2p, Male, .100"sp, Gold, Pb-Free	1		J7		
24										
25	HDWRE	0700440LN	MP		Hex Nut, 4-40 Nylon Locking. Pb Free	4				
26	HDWRE	36440MF075	MP		Standoff, Male/Female, Hex, 440x3/16, Nylon, Pb Fr	4			Mount On Bottom	
27	HDWRE	6INTLKWSSSROHS	ANY		Washer, #6 Internal Tooth, SS, ROHS	2			Use With Binding Posts	
28										

ENERCON - BILL OF MATERIALS	TITLE: NATIONAL SEMICONDUCTOR PCBA, SCAN90CP02EVK EVAL, ROHS	PL Number: Z3015-01	Rev: 2	Rev By: AF	Rev Date: 10/26/2006	PL Status: Released
		Main Product: PCBA, JTAG SCANCP02 EVAL, ROHS		Responsible Eng/Mgr: Ed Ballou	Creator: Arlene Fox	Creation Date: 10/2/2006

Item	Part Type	Part Number/Value	Mfg	NoSub	Description	Qty	SMT	Ref Des	Notes	Re
29	STENCL	T-05401R0	ENERCON		STENCIL FABRICATION, CP02 EVAL BOARD, ROHS, TOP	1				
30	STENCL	T-05404R0	ENERCON		STENCIL FABRICATION, CP02 EVAL BOARD, ROHS, BOTTOM					
31	REF	C-05406R0	ENERCON		PALLET DWG, CP02 EVAL BOARD, ROHS					
32	REF	C-05400R0	ENERCON		FABRICATION DWG, CP02 EVAL BOARD, ROHS					
33	REF	S-03832R3	ENERCON		SCHEMATIC, SCAN90CP02 EVAL BOARD					
34										