

TO-92

The TO-92 is designed to meet mechanical standards as set forth in JEDEC publication number 95.

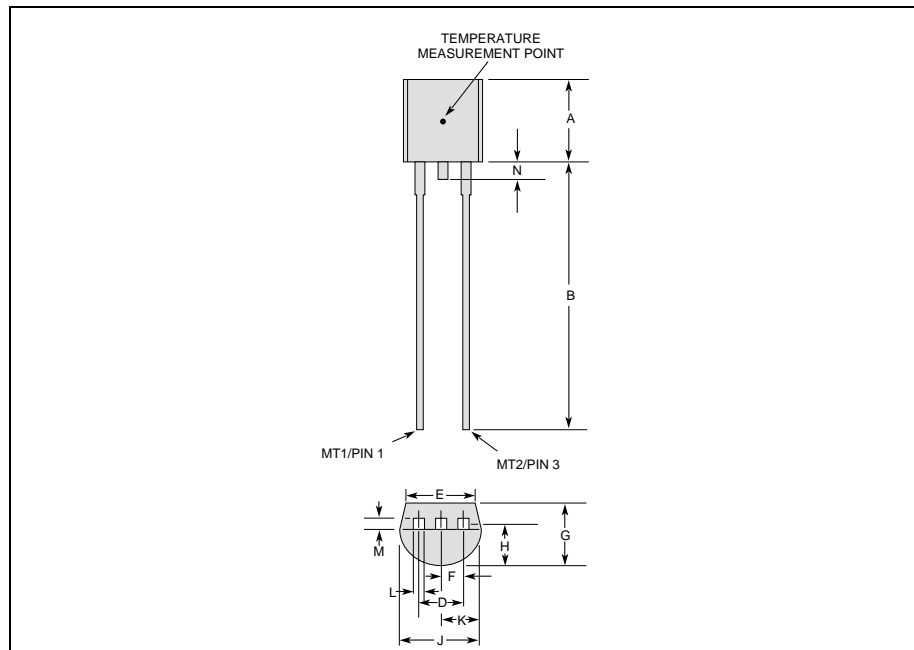

Dimension	Inches		Millimeters	
	MIN	MAX	MIN	MAX
A	0.176	0.196	4.47	4.98
B	0.500		12.70	
D	0.095	0.105	2.41	2.67
E	0.150		3.81	
F	0.046	0.054	1.16	1.37
G	0.135	0.145	3.43	3.68
H	0.088	0.096	2.23	2.44
J	0.176	0.186	4.47	4.73
K	0.088	0.096	2.23	2.44
L	0.013	0.019	0.33	0.48
M	0.013	0.017	0.33	0.43
N		0.060		1.52

General Notes:

- Type 70 lead form as shown is standard for the E package.
- All leads are insulated from case. Case is electrically non-conductive. (Rated at 1600 V ac rms for one minute from leads to case over the operating temperature range)
- Mold flash shall not exceed 0.13 mm per side.

Mechanical Data