

PROPER USE GUIDELINES

Cumulative Trauma Disorders can result from the prolonged use of manually powered hand tools. Hand tools are intended for occasional use and low volume applications. A wide selection of powered application equipment for extended-use, production operations is available.

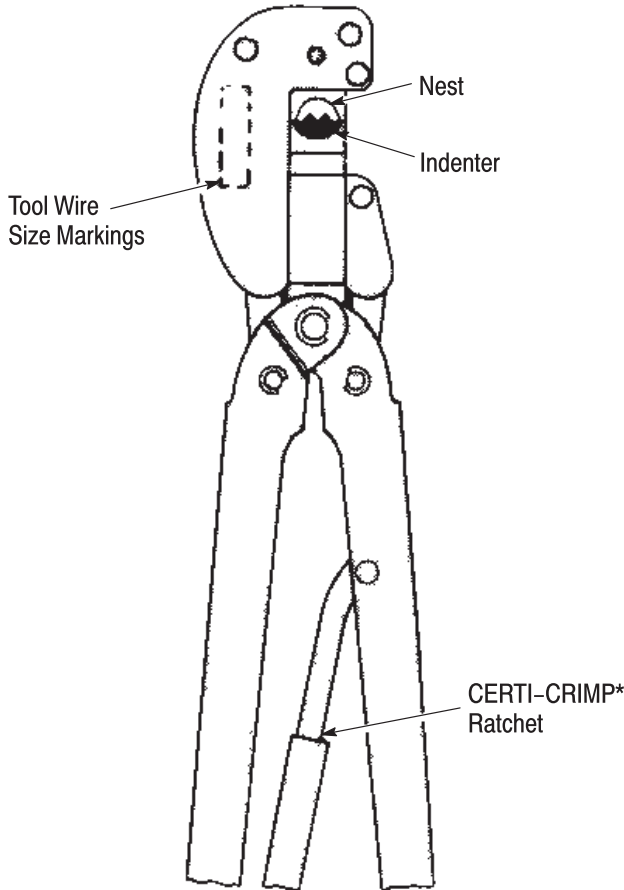

Figure 1

1. INTRODUCTION

This instruction sheet provides information for product application and maintenance and inspection procedures for Terminal and Splice Crimping Tools 69339, 69354-1, and 69355.

These tools are used to crimp:

- SOLISTRAND* Terminals, butt and parallel splices on solid or stranded copper wire sizes 6 and 8 AWG
- SOLISTRAND Flag Terminals on solid or stranded copper wire size 8 AWG
- STRATO-THERM* heat resistant uninsulated terminals on solid or stranded copper wire size 8 AWG

Basic instructions on the use of this tool, wire preparation, tool adjustments, etc. are provided in Section 2, INSTRUCTIONS. Section 3 features a terminal CRIMP INSPECTION procedure. Section 4 contains a MAINTENANCE and INSPECTION PROCEDURE.

Tools are coated with preservative to prevent rust and corrosion. Wipe this preservative from the tool, particularly from the crimping area.

NOTE *Dimensions are in millimeters [with inch equivalents in brackets]. Figures and illustrations are for identification only and are not drawn to scale.*

Read these instructions carefully before using the tool.

Reasons for reissue of this sheet are provided in Section 5, REVISION SUMMARY.

2. INSTRUCTIONS FOR WIRE STRIPPING AND CRIMPING PROCEDURES

1. Strip wires to the dimensions listed in Figure 2.

CAUTION *Do NOT use wire with nicked or missing strands.*

2. Open crimping dies by closing handles until CERTI-CRIMP ratchet releases. See Figure 1. Note that once the ratchet is engaged, handles cannot be opened again until they are fully closed.

NOTE *Be sure wire size displayed on tool head and in stationary die nest matches wire size stamped on the terminal or splice.*

Determine correct terminal or splice wire loading by referring to the CMA range listed in Figure 2.

Terminals

3. Center wire barrel of terminal in nest of stationary die as shown in Figure 3A.
4. Center wire barrel of flag terminal in dies being sure that "tongue" portion of wire barrel is against indenter of moving die as shown in Figure 3B.

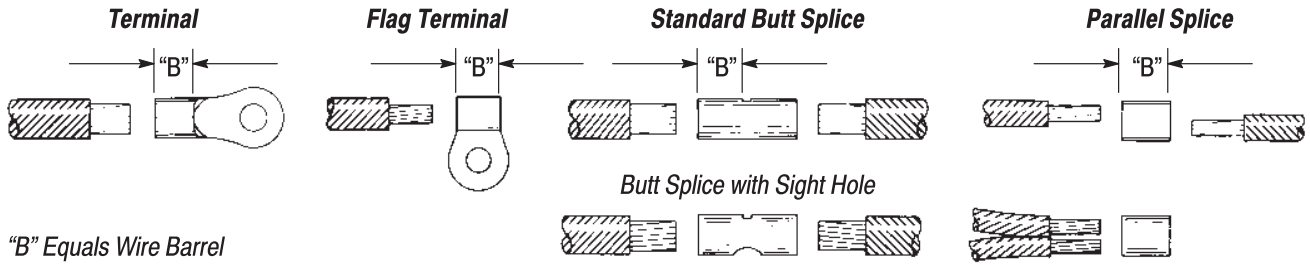

"B" Equals Wire Barrel

TOOL NUMBER	WIRE SIZE	CIRCULAR MILL AREA RANGE	WIRE STRIP LENGTH (mm [in.])							
			TERMINAL		FLAG TERMINAL		BUTT SPLICE		PARALLEL SPLICE	
			Min.	Max.	Min.	Max.	Min.	Max.	Min.	Max.
69339●	8	13,100-20,800	8.33 [.328]	9.12 [.359]	---	---	10.31 [.406]	11.13 [.438]	10.31 [.406]	11.13 [.438]
69354-1●●	8		---	---	9.52 [.375]	11.13 [.438]	---	---	---	---
69355●●●	8		8.33 [.328]	9.12 [.359]	---	---	10.31 [.406]	11.13 [.438]	10.31 [.406]	11.13 [.438]

●Stranded wire only. ●●Flag terminals only. ●●●Also used for STRATO-THERM Heat Resistant Terminals.

Figure 2

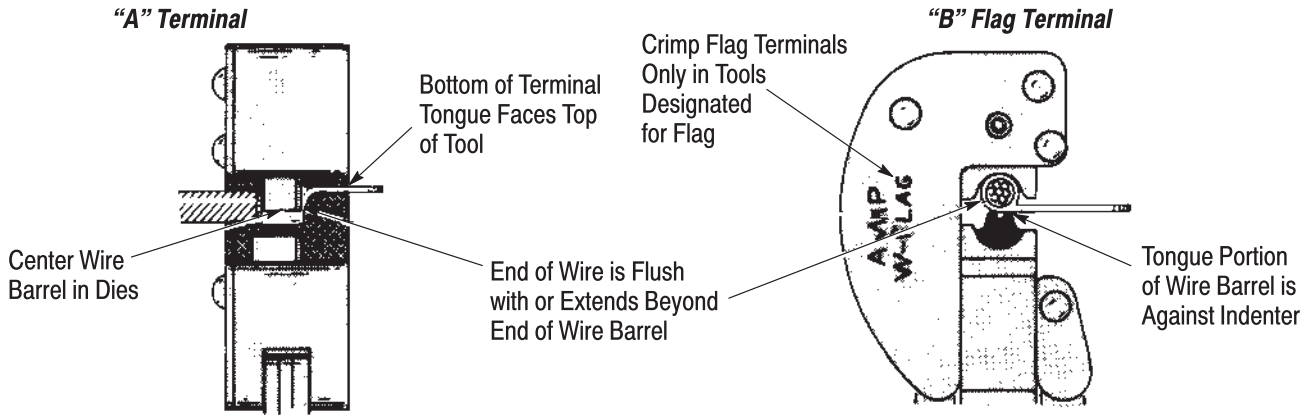

Figure 3

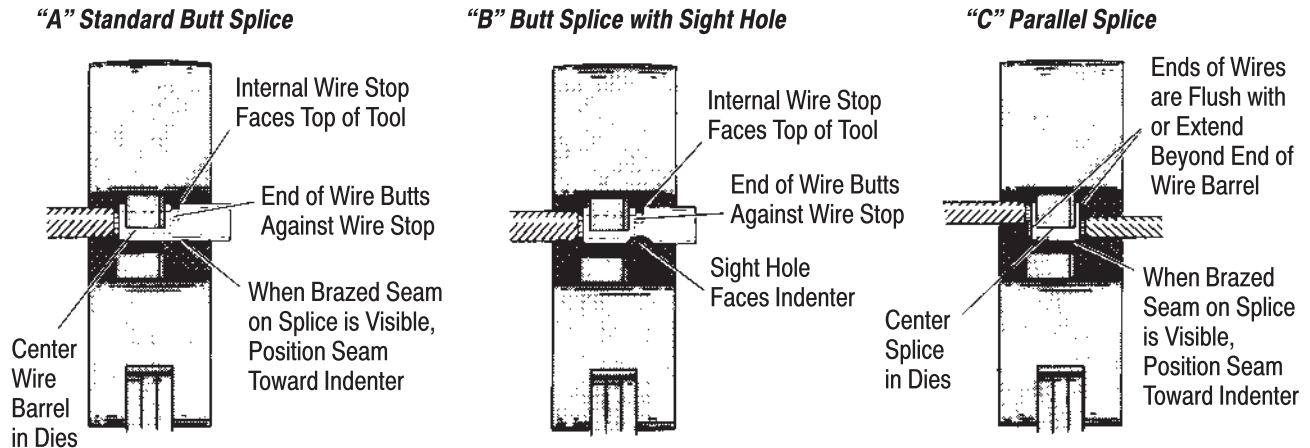

Figure 4

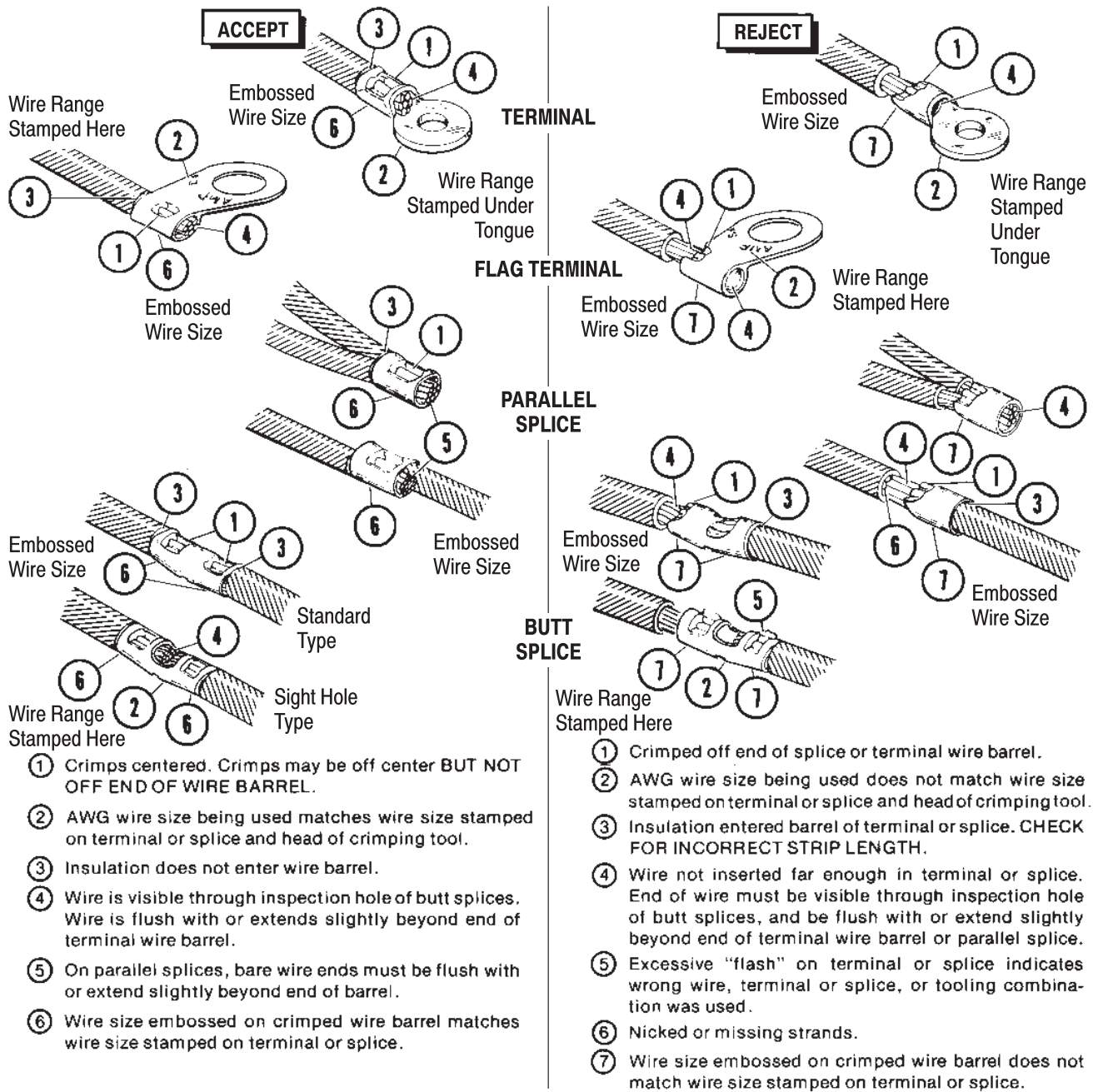

Figure 5

5. Close handles until terminal is held firmly in place. Do NOT deform terminal wire barrel.

6. Insert stripped wire into terminal until end of wire is at least flush with or extended slightly beyond end of wire barrel. See Figures 3A or 3B.

7. To complete the crimp, close the handles until the CERTI-CRIMP ratchet releases. Handles can now be opened and the crimped terminal may be removed.

8. Refer to Section 3 and Figure 5 for terminal crimp inspection procedures.

Splices

9. Center one half of the butt splice in nest as shown in Figure 4A or 4B. For best results, when brazed seam on splice is visible, position the seam toward the indenter.

10. Center parallel splice in nest as shown in Figure 4C. Be sure brazed seam faces indenter.

11. Close handles until splice is held firmly in place. Do NOT deform splice wire barrel.

12. Insert stripped wire into butt splices until end of wire butts against wire stop in splice as shown in Figure 4A or 4B. Insert stripped wire into parallel

splices until end of wire is flush with or extended slightly beyond end of wire barrel as shown in Figure 4C.

13. To complete crimp, close the handles until the CERTI-CRIMP ratchet releases. Handles can now be opened and the crimped splice may be removed.

14. To crimp the other half of the butt splice, remove it and re-position uncrimped half in nest. Follow the same procedure used to crimp the first half of the splice.

15. Refer to Section 3 and Figure 5 for splice crimp inspection procedures.

3. CRIMP INSPECTION

Inspect crimped terminals and splices by checking the features described in Figure 5. Use only the terminals and splices that meet the conditions shown in the "ACCEPT" column. "REJECT" terminals and splices can be avoided through careful use of instructions in Section 2 and by performing regular tool maintenance as instructed in Section 4.

4. MAINTENANCE/INSPECTION PROCEDURE

Tyco Electronics recommends that a maintenance/inspection program be performed periodically to ensure dependable and uniform terminations. Tools should be inspected at least once a month. Frequency of inspection may be adjusted to suit your requirements through experience. Frequency of inspection is dependent upon:

- The care, amount of use, and handling of the tool
- The type and size of the products crimped
- The degree of operator skill
- The presence of abnormal amounts of dust and dirt
- Your own established standards

All tools are inspected and calibrated before packaging. Since there is a possibility of tool damage in shipment, new tools should be inspected in accordance with Section 4 when received in your plant. Due to the precision design, *it is important that no parts of these tools be interchanged except those replacement parts listed in Figure 9.*

4.1. Cleaning

The tool should be immersed (handles partially closed) in degreasing compound to remove accumulated dirt, grease, and foreign matter. Remove remaining degreasing compound with a lint free cloth. When degreasing compounds are not available, tool may be wiped clean with a lint-free cloth. Relubricate

tool, as instructed in Paragraph 4.3, before placing it back in service.

4.2. Visual Inspection

1. Inspect the tool for missing pins or retaining rings. If parts are missing or defective, refer to Figure 9 for customer replaceable parts.
2. Inspect the die closure surfaces for flattened, broken, or chipped conditions. Although dies may gage within permissible limits, worn or damaged die closure surfaces are objectionable and can affect the quality of the crimp. Examples of possible damaged die closure surfaces are shown in Figure 6.

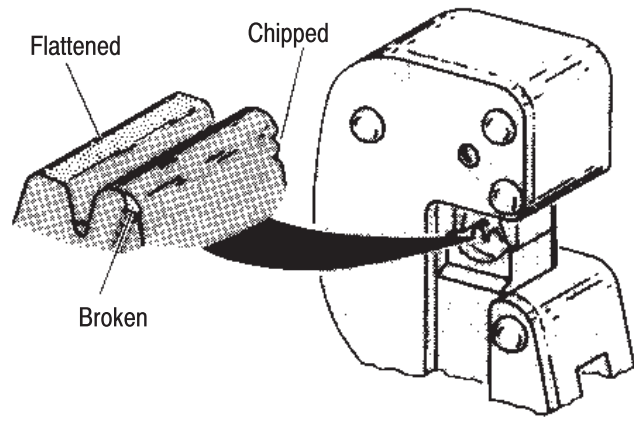

Figure 6

4.3. Lubrication

Lubricate all pins, pivot points, and bearing surfaces with a good grade S.A.E. No. 20 motor oil as follows:

- Tools used in daily production – Lubricate daily
- Tools used daily (occasional) – Lubricate weekly
- Tools used weekly – Lubricate monthly

Wipe excess oil from tool, particularly from crimping area. Oil transferred from the crimping area onto certain terminations may affect the electrical characteristics of an application.

4.4. Die Closure Inspection

Each tool is inspected for proper die closure before packaging. An inspection should be performed periodically to check the tool die closure for excessive wear.

The die closure inspection is accomplished using a GO/NO-GO plug gage. Tyco Electronics neither manufactures nor sells plug gages. Suggested design and GO/NO-GO dimensions for the plug gage members are listed in Figure 7. The following procedure is recommended for inspecting the die closure.

SUGGESTED PLUG GAGE DESIGN - WIRE BARREL CRIMP

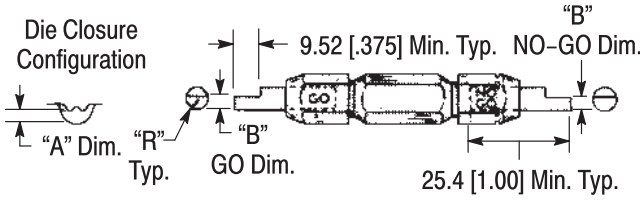

TOOL	DIE CLOSURE DIM's "A"†		GAGE MEMBER‡ DIM's "B"		RADIUS "R"
	GO	NO-GO	GO	NO-GO	
69339	3.200 [.1260]	3.353 [.1320]	3.200-3.208 [.1260-.1263]	3.350-3.353 [.1319-.1320]	3.51 [.138]
69354-1	2.540 [.1000]	2.692 [.1060]	2.540-2.548 [.1000-.1003]	2.690-2.692 [.1059-.1060]	3.18 [.125]
69355	2.540 [.1000]	2.692 [.1060]	2.540-2.548 [.1000-.1003]	2.690-2.692 [.1059-.1060]	3.18 [.125]

†Die closure dimensions apply when dies are bottomed but not under pressure. ‡Material-Tool Steel

Figure 7

1. Clean oil or dirt from the die closure and plug gage members.
2. Close handles of tool until dies are bottomed. Do NOT apply additional pressure to tool handles. see Figure 8A.
3. With dies bottomed, inspect the die closure using the proper plug gage.
4. Hold gage in straight alignment with the die closure and carefully try to insert, without forcing, the GO member. See Figure 8, Detail A. The GO member must pass completely through the die closure.
5. Try to insert the NO-GO member. The NO-GO member may enter partially, but must not pass completely through the die closure.

INSPECTION OF WIRE BARREL CRIMPING DIES

Dies Bottom Here in Flag Terminal Crimping Tool

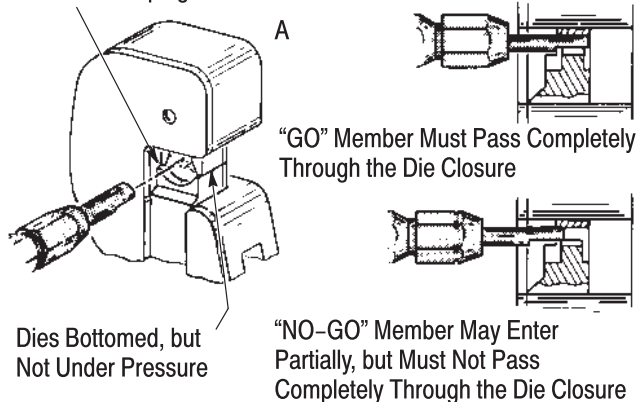

Figure 8

6. If the die closure meets the GO/NO-GO gage conditions, the die closure may be considered dimensionally correct.

7. If you find that the die closure does not conform with the GO/NO-GO gage conditions, contact your local Tyco Electronics Representative.

4.5. CERTI-CRIMP Ratchet Inspection

The CERTI-CRIMP ratchet feature on hand tools should be checked to make certain that the ratchet does not release prematurely allowing dies to open before they have fully bottomed. To check the ratchet feature:

1. Thoroughly clean the bottoming surfaces of the dies.
2. Make a test crimp using a properly stripped No. 8 AWG wire and a terminal. When this crimp is made, squeeze handles until the ratchet is free, however, DO NOT RELAX PRESSURE ON TOOL HANDLES.
3. Bottoming is satisfactory if bottoming surfaces of the wire barrel crimp dies make contact with each other or if the clearance between the bottoming surfaces is 0.03 mm [.001 in.] or less.
4. If the 0.03 mm [.001 in.] shim stock can be inserted completely between the bottoming surfaces of the wire barrel crimp dies, the dies are considered as not bottoming. Contact your local Tyco Electronics Representative.

4.6. Replacement Parts

The parts listed in Figure 9 are customer-replaceable. A complete inventory can be stocked and controlled to prevent lost time when replacement of parts is necessary. Order replacement parts through your Tyco Electronics Representative, or call 1-800-526-5142, or send a facsimile of your purchase order to 717-986-7605, or write to:

CUSTOMER SERVICE (38-35)
 TYCO ELECTRONICS CORPORATION
 P.O. BOX 3608
 HARRISBURG PA 17105-3608

Tools may be returned to Tyco Electronics for evaluation and repair. For tool repair service, contact a Tyco Electronics Representative at 1-800-526-5136.

5. REVISION SUMMARY

- Updated document to corporate requirements
- Deleted obsolete tools and related information
- Changed radius dimension in table in Figure 7

NOTE: Approximately [12.125 in.] Long, Assembled, and Handles Closed

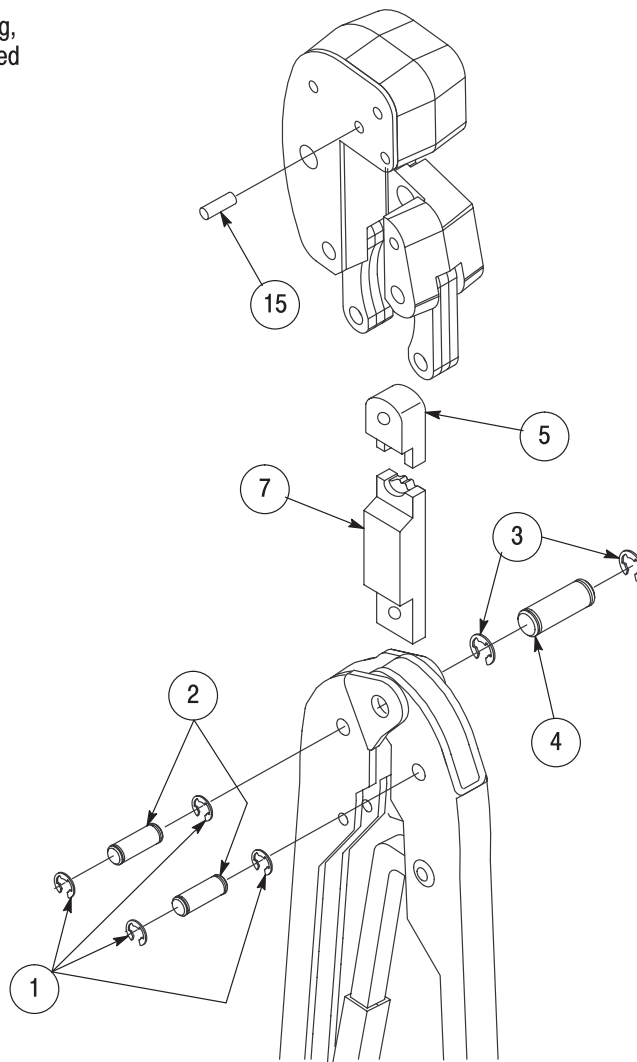

ITEM No.	DESCRIPTION	QTY PER TOOL	HAND TOOLS		
			69339	69354-1	69355
1	RING, Retaining	4	21045-3	21045-3	21045-3
2	PIN	2	300388	300388	300388
3	RING, Retaining	2	21045-6	21045-6	21045-6
4	PIN	1	300389	300389	300389
5	NEST	1	306079-1	---	306079-1
7	INDENTER	1	306078-7	---	306078-2
8	HANDLE, Stub Head	2	---	---	---
9	RIVET	2	---	---	---
10	HANDLE	2	---	---	---
11	HANDLE ASSEMBLY	2	---	---	---
12	SCREW, Set	2	---	---	---
13	EXTENSION, Handle	2	---	---	---
14	GRIP, Handle	2	---	---	---
15	PIN	1	5-21028-7	5-21028-7	5-21028-7

Figure 9